

GENERAL
CATALOGUE

2020 - 2021

Ex PRODUCTS

Ex PRODUCTS CATALOGUE

2020 - 2021



www.scame.com

INDEX	PAGE 2
COMPANY	PAGE 4
GUIDE TO THE ATEX DIRECTIVES	PAGE 6
CATALOGUE	PAGE 24
PRODUCTS CATALOGUE	
INDEX BY PRODUCT NUMBER	PAGE 151

1	ATEX-IECEX-EAC Ex [Ex II 2GD]	page 24
	- ADVANCE-GRP[GD] Series	page 26
	- OPTIMA-EX[GD] Series	page 32
	- ISOLATORS-EX[GD] Series	page 36
	- ROCKER-EX[GD] Series	page 42
	- ZENITH-P Series	page 44
	- ZENITH-S Series	page 60
	- UNION-EX Series	page 80
2	ATEX [Ex II 2D]	page 110
	- ADVANCE-GRP[EX] Series	page 112
	- OPTIMA-EX Series	page 116
	- ISOLATORS-EX Series	page 120
3	ATEX [Ex II 3D] • ATEX [Ex II 3GD]	page 130
	- ADVANCE-GRP[EX] System	page 132
	- ADVANCE-GRP[EX] 125A Series	page 136
	- OPTIMA-EX 125A Series	page 138
	- ADVANCE-GRP[EX] 24V Series	page 140
	- OPTIMA-EX 24V Series	page 142
	- ALUBOX-EX Series	page 144

The company

“

In over
fifty years
we have built an
industrial reality
that has always
maintained the spirit
of its **origins**

”



Stefano Scainelli CEO



THE CONCEPT OF QUALITY IS AN INTEGRAL PART OF OUR CULTURE IN ALL ASPECTS AND EVERY ACTIVITY OF OUR WORK.



SCAME PARRE S.p.A., head of the SCAME group, is a manufacturer of components and systems for electrical installations in the civil, services and industrial sector, born and raised in the mountains of the upper Val Seriana, in the Province of Bergamo, Northern Italy.

Since 1963, the year of its foundation, in more than half a century of activity, SCAME has never betrayed the spirit of the origins made of attention to the environment and the person, as well as continuous research to provide an innovation that is never an end in itself, but which translates into total quality and real benefits for the user.

Already a pioneer in the field of the solutions dedicated to charging electric vehicles, for which it is now an absolute benchmark, the continuous search for new markets has led SCAME to develop also an articulated range of ATEX IEC-Ex products for installation in hazardous areas, without neglecting its traditional offer based on products for domestic and industrial applications, even heavy ones.

A catalog able to meet any installation requirement, a product quality guaranteed by compliance with national and international Standards, a rapid customer service able to support every choice and an high level of service, have enabled SCAME to affirm its presence not only nationally, but also internationally through a network of 17 branches and a consolidated network of distributors in over 80 countries on 5 continents.



SCAME
electrical solutions
Italy, Parre (Bergamo)



SCAME ARGENTINA
Argentina

SCAME BULGARIA
Bulgaria

SCAME BRASIL
Brazil

SCAME CHILE
Chile

SCAME-TOP
China

SCAME-CZ
Czech Republic

SOBEM SCAME
France

SCAME INDIA
India

SCAME POLSKA
Poland

SCAME PORTUGAL
Portugal

SCAME-RO
Romania

SCAME-SK
Slovakia

SCAME IBERICA
Spain

SCAME MIDDLE EAST
U.A.E.

SCAME-UK
United Kingdom

SCAME-UY
Uruguay

SCAME-UA
Ukraine

Guide to the ATEX directives

1. THE RISK OF EXPLOSION

An explosive atmosphere is a mixture of flammable substance with air in such concentration that, after ignition has occurred, combustion quickly spreads to the flammable mixture (in the order of milliseconds) not compatible with the development of fire.

The flammable substance can be formed from substances in the state of gas, vapours, mists or combustible dusts, which can be released by the air containment system under normal atmospheric conditions. The risk of explosion treated by the rule of art referred to in this guide relates to mixtures in normal atmospheric conditions and explosives or chemically unstable substances are excluded. When released, a flammable substance, in order to generate an explosive atmosphere, must be present in concentration in the air which is included between two limits: a lower one (LEL) and an upper one (UEL). Outside the range of the two limits, no explosion occurs. When within the interval, the mixture is in the explosive range and if a source of ignition of sufficient energy is present, the explosion occurs. Explosive limits and minimum ignition energy are characteristics of each flammable substance, both gases and dusts.

The ignition sources can be of different nature: temperature, friction, mechanical spark, electric spark, electrostatic discharge, light sources, ultrasound, electromagnetic fields.

The phenomenon is described by the well-known fire triangle (gases) and by the explosion pentagon (dusts).

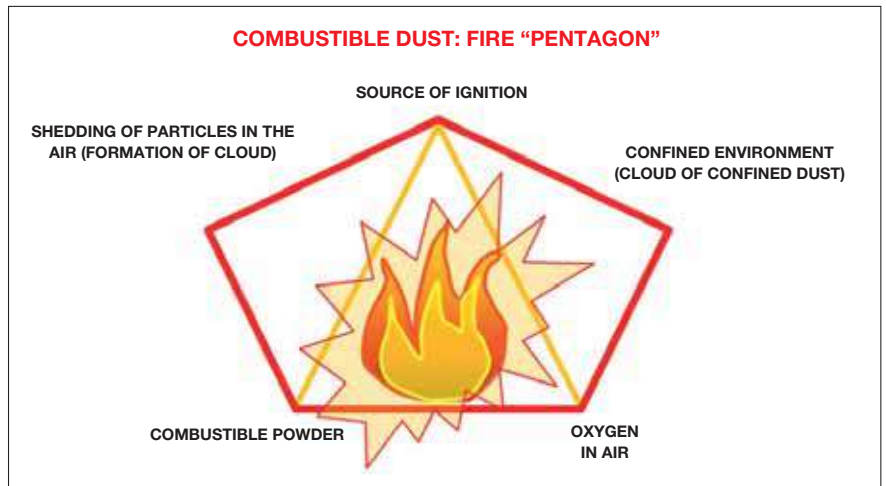
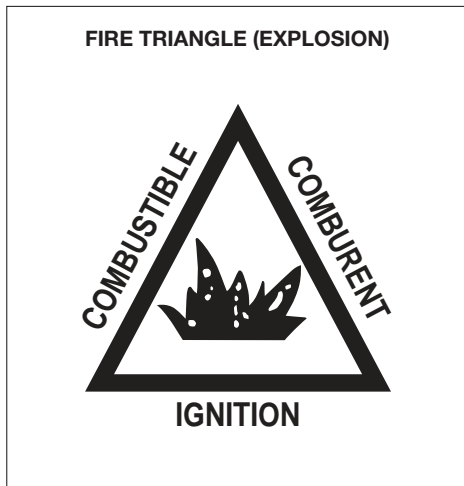

2. THE WORLD Ex - IEC ZONE SYSTEM

IEC (International Electrotechnical Commission) has been dealing with the prevention and protection approach in places at high risk of explosion, by means of standards (IEC standards) which regulate a system also known as IEC ZONE SYSTEM.

The IEC ZONE SYSTEM is based on the integration of the prevention and protection requirements entrusted to specific reference figures: the manufacturer of the equipment, the system manager (typically the employer), the plant designer and the manufacturer of the plant (equipment selection and installation). IEC standards entrust each of these roles with responsibilities.

The system is based on the classification of places in hazardous areas and on the classification of equipment. Workplaces with the presence of flammable substances are classified into: 3 hazardous areas with increasing probability of presence and persistence of explosive atmosphere. The equipment manufacturer classifies them in: 3 groups (in relation to the substance which generates the explosive atmosphere) and in 3 safety levels (in relation to the ability not to ignite in different operating conditions: in case of failures or in normal operation).

Prevention and protection are implemented by the correct choice and installation of the classification of the equipment for the specific classified area.

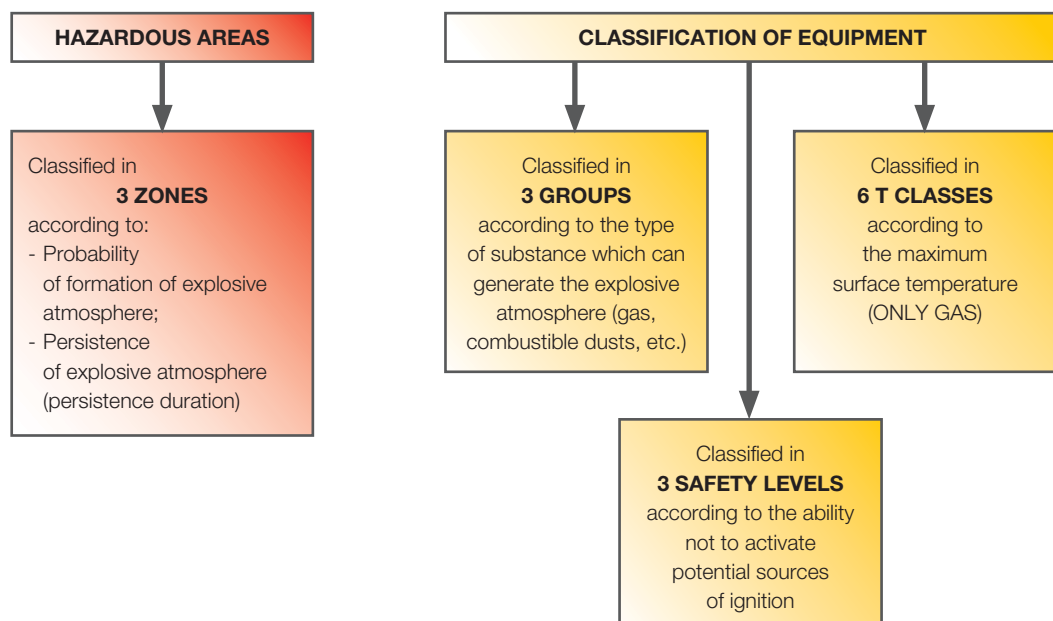

The Zones/Equipment system suitable for the zones establishes requirements for equipment and systems and identifies the various technical figures with the related responsibilities and competences.

SYSTEM	ACTION	IEC STANDARD	RESPONSIBLE	COMPETENCES (#)	REFERENCES TO ITALIAN DIRECTIVES AND LAW
HAZARDOUS AREAS	CLASSIFICATION	60079-10	EMPLOYER / PLANT MANAGER	General information on the explosion danger Substances and production processes Protective equipment and techniques	ATEX 99/92/CE DIRECTIVE Legislative Decree 81/08 Title XI Criminal and/or administrative sanctions
EQUIPMENT	CONSTRUCTION OF EQUIPMENT WITH PROTECTION TECHNIQUES	60079 -0 AND PARTS 1, 2, 7, 11, 15, 18, 31, etc. depending on the type of protection	APPLIANCE MANUFACTURER	General information on the explosion danger Specifications on protection techniques (protection modes) Specifications on certification procedures	ATEX DIRECTIVE 2014/34/EU Legislative Decree dated 19 May 2016, no. 85 Administrative sanctions (sanctions in case of proven fault)
ELECTRICAL SYSTEM	DESIGN, SELECTION AND INSTALLATION OF THE EQUIPMENT	60079-14 (National Guide CEI Guide 31-108)	EMPLOYER / PLANT MANAGER DESIGNER INSTALLER	DIFFERENT LEVEL ACCORDING TO THE ROLE: General information on the explosion danger Specifications on protection techniques (protection modes) Knowing how to read markings and product docs Specifications on the system standard and on the additional requirements of the standard with respect to the protection mode THEY MUST NOT NEGATIVELY AFFECT THE PROTECTION OF THE EQUIPMENT IN THE CHOICE OR INSTALLATION OF THE EQUIPMENT	M.D. 37/08 The employer has the obligation to choose the designer and executors with the required skills Obligation to design in compliance with the state of the art by a qualified professional The installer performs in compliance with the state of the art and draws up a declaration of conformity Administrative sanctions (sanctions in case of proven fault)
ELECTRICAL SYSTEM	VERIFICATION	60079-17	EMPLOYER / PLANT MANAGER ELECTRIC WORKER	DIFFERENT LEVEL ACCORDING TO THE ROLE: General information on the explosion danger Specifications on protection techniques (protection modes) Knowing how to read markings and product docs Specifications on the system standard and on the additional requirements of the standard with respect to the protection mode THEY MUST GUARANTEE EFFECTIVE PROTECTION OVER TIME	Legislative Decree 81/08 Decree of the President of the Republic 462/01 The employer is required to carry out regular maintenance of the system, as well as to have it periodically checked (2 YEARS) by a qualified body The maintenance obligation of the employer requires a frequency of verification in relation to the characteristics of the system, not necessarily done by a qualified body

What does it mean to have the competences and who confers them?

The competences required for the design of electrical systems, the choice and correct installation of electrical equipment are defined in Annex A (normative) of the IEC 60079-14 standard, implemented in Italy by the CEI as CEI EN 60079-14 Standard. The annex explains the **knowledge, skills and competences of the responsible staff, operators/technicians and designers**, as a "regulatory requirement".

This means that declaring a system compliant with the CEI EN 60079-14 standard, for example in a declaration of conformity (DICO) in compliance with D.M. 37/08, means declaring one's specific competence in the field of electrical systems in places with risk of explosion.

Italy has to date no National Law or Standard or National certification scheme of personal competence, which can give evidence of a third party that can attest to having the required knowledge.

The legal obligation of competence remains implicit in the application of the technical standard.

However, there are certification schemes which can certify competences in compliance with IEC 60079-14 and IEC 60079-17 (verifications), but it is up to the individual's will to comply with them or not and often require travelling abroad. Some of these schemes are: IECEx CoP (IEC certification, international), Compex (UK), IsmATEX (France), etc.

Guide to the ATEX directives

3. IEC ZONE SYSTEM - CLASSIFICATION OF AREAS

ZONE	ATMOSPHERE	DEFINITION	STANDARD TO CLASSIFY
ZONE 0	GAS, STEAM	An area in which an explosive atmosphere consisting of a mixture of air and flammable substances in the form of gas, vapour or mist is present permanently, for long periods or often. (> 1000 hours/year)	IEC EN 60079-10-1
ZONE 1		Area in which, during normal activities, the formation of an explosive atmosphere consisting of a mixture of air and flammable substances in the form of gas, vapour or mist is likely. (10 - 1000 hours/year)	
ZONE 2		Area in which, during normal activities, the formation of an explosive atmosphere consisting of a mixture of air and flammable substances in the form of gas, vapour or mist is not likely and, if it occurs, it is only of short duration. (< 10 hours/year)	
ZONE 20	COMBUSTIBLE DUST	Area in which an explosive atmosphere in the form of a cloud of combustible dust in the air is present permanently, for long periods or often. (> 1000 hours/year)	IEC EN 60079-10-2
ZONE 21		Area in which, during normal activities, the formation of an explosive atmosphere in the form of a cloud of combustible dust in the air is likely. (10 - 1000 hours/year)	
ZONE 22		Area in which, during normal activities, the formation of an explosive atmosphere in the form of a cloud of combustible dust in the air is not likely and, if it occurs, it is only of short duration. (< 10 hours/year)	

4. IEC ZONE SYSTEM - CLASSIFICATION OF EQUIPMENT

CLASSIFICATION OF EQUIPMENT IN GROUPS (FLAMMABLE SUBSTANCE)

GROUP	EQUIPMENT FOR
GROUP I	Grisou Gas Mine
GROUP IIA	Propane
GROUP IIB	Ethylene
GROUP IIC	Hydrogen and Acetylene
GROUP IIIA	Combustible fibres
GROUP IIIB	Non-conductive dusts
GROUP IIIC	Conductive dusts

CLASSIFICATION OF EQUIPMENT IN TEMPERATURE CLASSES (GAS, STEAM ONLY)

TEMPERATURE CLASS	MAXIMUM SURFACE T
T1	450 °C
T2	300 °C
T3	200 °C
T4	135 °C
T5	100 °C
T6	85 °C

The maximum surface temperature of a piece of equipment for flammable gases or vapours is the maximum temperature reached by the hottest part of the equipment in contact with the explosive atmosphere, which can be outside or inside the enclosure, depending on the type of product, when it is at the maximum declared ambient temperature.

DUST equipment is not classified in Temperature classes, because the IEC system takes into account the two trigger temperatures which characterise dust: **Tcl** (dust cloud ignition T) and **Tl** (dust layer ignition T).

CLASSIFICATION OF EQUIPMENT IN COMPLIANCE WITH THE LEVEL OF PROTECTION

(EPL - Equipment Protection Level)

ALL ATMOSPHERES

Protection levels (EPL) in compliance with IEC 60079 classification			
ATMOSPHERE	EPL	PROTECTION LEVEL	INSTALLATION AREA
MINE GAS GROUP I	Ma	VERY HIGH	--
	Mb	HIGH	--
SURFACE GAS GROUP IIA, IIB, IIC	Ga	VERY HIGH	ZONE 0
	Gb	HIGH	ZONE 1
	Gc	NORMAL	ZONE 2
COMBUSTIBLE DUST GROUP IIIA, IIIB, IIIC	Da	VERY HIGH	ZONE 20
	Db	HIGH	ZONE 21
	Dc	NORMAL	ZONE 22

5. IEC ZONE SYSTEM - EQUIPMENT BUILT NOT TO IGNITE: THE PROTECTION MODES

The equipment which complies with the IEC 60079 system is called "Ex" equipment. The two letters are also used as a prefix in the marking of the product, when it is built with one of the protection techniques against ignition, also called "protection modes".

There are different ways of protection depending on the method by which ignition and explosive atmosphere are prevented from meeting:

1. Atmosphere and ignition are allowed to come into contact within the enclosure. The enclosure is constructed in such a way as to withstand the stresses of an internal explosion and not to propagate the flame outside
2. Atmosphere and ignition cannot come into contact: by means of physical impediment or by limiting the presence of the ignition to conditions of rare probability
3. The ignition energy is limited below the minimum energy values of ignition of the atmosphere (energy limitation)

Each type is developed in different protection modes.

Protection mode	IEC / EN standard	Definition	Connection with types 1, 2 and 3
d	60079-1	Explosion-proof enclosures	type 1: PROTECTION
p	60079-2	Internal overpressure	type 2: PREVENTION - Absence of explosive atmosphere
e	60079-7	Increased security	type 2: PREVENTION - Absence of ignition source
i	60079-11	Intrinsic safety	type 3: PREVENTION - Energy limitation
n	60079-15	Protection mode "n"	type 2: PREVENTION - "nC" (hermetically sealed) and "nR" (limited breathing) modes
m	60079-18	Protection by encapsulation	type 2: PREVENTION - Absence of explosive atmosphere
t	60079-31	Protection by "t" enclosures (combustible dusts)	type 2: PREVENTION - Absence of explosive atmosphere

Note 1: The table above shows only the techniques most commonly used in plants. There are other protection modes depending on the technique used and the type of product.

Guide to the ATEX directives

Note 2: The "n" protection mode (standard 60079-15) has changed over time in relation to the evolution of the standards. In fact, in the standard, the following can no longer be found:

- the "nA" mode: transferred to the 60079-7 standard of the protection mode "e" of increased safety, as a protection mode with increased safety for "ec";
- the "nC" Enclosed Break mode: transferred to the 60079-1 standard of the protection mode "d", as explosion-proof enclosures "dc";
- the "nL" mode: transferred to the 60079-11 standard of the intrinsically safe protection mode, as the intrinsic safety protection mode "ic".

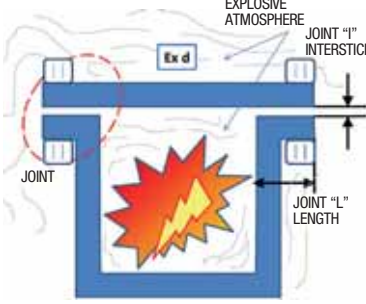
Protection mode	IEC / EN standard	Main features	Installation requirements IEC EN 60079-14	Critical verification requirements IEC EN 60079-17	Contents
d	60079-1	 <p>FOR GAS ATMOSPHERES ONLY SPARKLING COMPONENTS PROTECTION LEVEL: - VERY HIGH "Ga" (very small volumes) → ZONE 0 - HIGH "Gb" → ZONE 1 - NORMAL "Gc" (the old "nC" enclosed break) → ZONE 2</p> <p>What does protection do? External enclosure</p> <ul style="list-style-type: none"> - equipment and components inside the enclosure can be standard (both sparking and non-sparking); - gas can enter inside the enclosure; - if the explosive atmosphere is ignited: <ol style="list-style-type: none"> 1. The enclosure holds the pressure resulting from the explosion, without being damaged; 2. the joints of the enclosure are designed in such a way that the flame, by passing through them, cools down and only the combustion product arrives outside, which is unable to ignite the surrounding atmosphere. Due to this, Length and <i>Maximum interstice</i> of the joints are regulated according to the gas GROUP; <p>APPLICATIONS: switches, electric actuators, junction boxes, electrical panels, motors, lamps, etc.</p>	<p>Ex "d" enclosures and components, provided only with a component certificate, i.e. marked with the suffix "U", must not be installed in a dangerous place if they are not part of a set with Ex certificate of complete equipment: taking an empty case and building a painting is NOT allowed.</p> <p>Additional holes or modifications to the entrances of an Ex "d" enclosure must be made only by the manufacturer or by a specially qualified and certified service centre.</p> <p>Keep the distance from obstacles (e.g. walls) of the standard according to the gas Group.</p> <p>Explosion-proof joints must not be painted.</p> <p>Special requirements for the use of grease to protect the joint from corrosion</p> <p>Particular requirements on taping of the flange-joint (not allowed for Group IIC)</p> <p>CABLE ENTRIES Plugs certified with "d" for the same gas Group as the equipment.</p> <p>You can use cable gland ONLY if marked "d" for the same gas Group as the equipment. The type of cable gland can be with rubber seal or "barrier" (sealed). This depends on the type of cable. The standard provides requirements for the choice of the type.</p> <p>Entry into the equipment with protection mode "d" can take place:</p> <ul style="list-style-type: none"> - directly with a sealed explosion-proof cable gland (barrier cable glands), which has an external sealing rubber and has a part, directly in communication with the housing of the "d" equipment, which is sealed on the conductors with a special compound during the installation phase (e.g. two-component resin); - directly with cable gland "d" equipped with a sealing ring (compression) or rubber seal; - directly in the protection tube and related connection components (e.g. fittings, locking fitting); - indirectly, through the use of a combination between an explosion-proof enclosure "d" equipped with a loop and an increased safety terminal box. <p>When using armoured cables, pay attention to the correct assembly of the cable gland in order to guarantee suitable compression of the armour and the consequent continuity on grounding</p> <p>If the entry is in conduit:</p> <ul style="list-style-type: none"> - locking fitting certified with "d" for the same gas group as the equipment, installed as close as possible to the enclosure. - between enclosure and locking fitting: certified components. - after the locking fitting: non-certified components (e.g. conduit). <p>The locking fitting must be installed as close as possible to the walls of the enclosure "d".</p>	<ul style="list-style-type: none"> - No tampering - No changes - No damage on the rolling joint - Cable glands, caps, bolts, locking fittings of the correct type (also verify the Gas group) and tightened fully or as per instructions - Suitable cable type - Specific conditions of safe use in the certificate and instructions, fulfilled - Additional requirements 60079-14 met (distance from obstacles, grease on the joint, no paint, etc.) - Verification of adequate protections against external atmospheric agents (corrosion, vibrations, etc.) 	<p>Advantages</p> <ul style="list-style-type: none"> - standard components, also sparking - IP rating does not ensure protection <p>ATTENTION:</p> <ul style="list-style-type: none"> - do not paint or scratch the joints - to tightening torques - do not lose bolts - to cable entries: choice of cable gland or locking fitting in case of conduit entry. - to cable gland preparation for armoured cable - if barrier cable gland or locking fitting: good execution of the two-component resin coating. - to equipotentiality on cable entries - if there are special conditions for safe use ("X" on the certificate and specific information in the documentation)

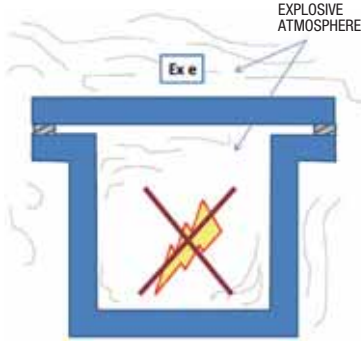
Protection mode	IEC / EN standard	Main features	Installation requirements IEC EN 60079-14	Critical verification requirements IEC EN 60079-17	Contents
e	60079-7	 <p>FOR GAS ATMOSPHERES ONLY NON-SPARKLING COMPONENTS PROTECTION LEVEL: - HIGH "Gb" → ZONE 1 - NORMAL "Gc" (the old "nA") → ZONE 2</p> <p>What does protection do? External enclosure + Internal components</p> <p>Additional measures are applied to provide increased safety against the possibility that the construction will not produce arcs, sparks or excessive temperatures, during normal operation or in specified abnormal conditions. It is applicable for equipment with nominal voltage up to 11 kV in AC/DC</p> <p>ENCLOSURE: IP protection requirements minimum IP54 obtained after: ageing (hot/cold), impact resistance (hot/cold), fall (if portable). The degree of protection has the purpose of preventing the penetration of solids or water (conductors) which may affect the insulation distances, which guarantee the maintenance of the non-sparking property. Non-metallic or metallic material.</p> <p>INTERNAL COMPONENTS: The requirements are such that the non-sparking components are "increased" by increasing insulation distances, mechanical fixings, vibration checks, choice of materials with increased electrical characteristics. Internal components must be certified as "e" components</p> <p>The temperature class of the building is defined by the maximum temperature reached by one part of the equipment under test in the conditions established by the standard, including the surfaces of internal parts to which the potentially explosive atmosphere can access</p> <p>APPLICATIONS: Terminal blocks and equipment terminals; coils; rotating electrical machines; lighting equipment; transformers; junction and junction boxes for general purposes; resistance heating devices (other than heating cables).</p>	<p>Ex "e" enclosures and components provided only with a component certificate, i.e. marked with the suffix "U", must not be installed in a dangerous place if they are not part of a set with Ex certificate of complete equipment: Taking an empty case and setting up a switchboard or junction box is NOT allowed.</p> <p>Additional holes or modifications to the entrances of an Ex "e" appliance must be made only by the manufacturer. Installation of other components inside the enclosure is not allowed.</p> <p>Requirements for limiting the temperature, especially to guarantee the disposal of the heat produced by the power dissipated inside the enclosure, in order to prevent the temperature from exceeding the temperature class of the equipment.</p> <p>The length of the conductors inside the enclosure should be kept as short as possible as a basis for the calculation and not greater than the length of the diagonal of the enclosure. Do not exceed the maximum of 6 conductors for each bundle inside the housing. Fully tighten unused terminals.</p> <p>The manufacturer's documentation contains information on:</p> <ul style="list-style-type: none"> - maximum number of terminals - size of the conductor - maximum current - maximum number of conductors for each connection point (the standard requires 1, but it depends on the certificate) - preparation of cable terminations: type of terminals, stripping length, etc. - terminal tightening torque - tightening torque of the enclosure screws <p>CABLE ENTRIES Certified plugs "e" for the same gas Group as the equipment.</p> <p>You can use a cable gland ONLY if marked "e" for the degree of protection of the construction certificate with the minimum IP54 (the standard also admits "d" but must guarantee the degree of protection of the certificate with a minimum IP54).</p>	<ul style="list-style-type: none"> - No tampering - No modifications (internal components and enclosure) - No damage on the enclosure - No damage to the seals on which the enclosure depends - No damage to cables and conductors - Minimum degree of protection IP54 (the one in the certificate) maintained during installation - Minimum degree of protection IP54 (the one in the certificate) maintained in the assembly of the entrances in the enclosure - Cable glands, caps, bolts of the correct type (also check the Gas Group) and tightened as per instructions - Tightening electrical connections and checking the terminals - Tightening the unused terminals to the bottom - Grounding of insulated metal parts (metal cable glands and cable armours) - protections of the motors "e" operating between the time limits tE or tA. - Clean and dry electrical insulating parts - Verification of adequate protections against external atmospheric agents (corrosion, vibrations, etc.) 	<p>Advantages</p> <ul style="list-style-type: none"> - Less rigid plant, closer to the concept of plant in ordinary places - No need for sealed cable entries <p>ATTENTION:</p> <ul style="list-style-type: none"> - do not damage the thermal part with use outside the ratings or with the addition of components - to tightening torques - to correct cable preparation - do not pile cables inside the enclosures - to insulation voltage of the cables in compliance with that of the equipment - do not lose bolts - to cable entries: choice of cable gland - to cable gland preparation for armoured cable - to equipotentiality on cable entries - to maintenance of IP degree - if there are special conditions for safe use ("X" on the certificate and specific information in the documentation)

Guide to the ATEX directives

Protection mode	IEC / EN standard	Main features	Installation requirements IEC EN 60079-14	Critical verification requirements IEC EN 60079-17	Contents												
i	60079-11	<p> $U_o \leq U_i$ $I_o \leq I_i$ $C_c = C_o - C_i$ $L_c = L_o - L_i$ </p> <p>FOR GAS AND DUST ATMOSPHERES SPARKING COMPONENTS PROTECTION LEVEL:</p> <ul style="list-style-type: none"> - VERY HIGH "Ga, Da" → ZONE 0, 20 - HIGH "Gb, Db" → ZONE 1, 21 - NORMAL "Gc, Dc" → ZONE 2, 22 <p>What does protection do? ALL the circuit is composed of: Associated construction (intrinsic safe barrier) + cables (type, section and length) + intrinsic safe equipment</p> <p>Energy is limited (a few watts, with short-circuit currents allowed up to a few Ampere units) through power supplies which supply power, voltage and current (U_o, I_o, P_o output), which is coordinated with the energy of the element in field (U_i, I_i, P_i), that is, if lower, they do not develop energy that triggers the explosive atmosphere, both in normal operation and in conditions of foreseeable and rare failure. Energy is also limited on the concentrated parameters of the circuit (C and L) and cables are also considered in the calculation.</p> <p>Depending on the operating condition in which the limitation is guaranteed (faults or normal operation), the circuit offers the following protection levels.</p> <table border="1"> <thead> <tr> <th>LEVEL OF PROTECTION (EPL)</th> <th>CONDITIONS WHICH IMPEDE IGNITION</th> <th>SYMBOL</th> </tr> </thead> <tbody> <tr> <td>Ga, Da</td> <td>- normal operation, and with the application of two faults - normal operation, and with the application of one fault - normal operation</td> <td>ia</td> </tr> <tr> <td>Gb, Db</td> <td>- normal operation, and with the application of one fault - normal operation</td> <td>ib</td> </tr> <tr> <td>Gc, Dc</td> <td>- normal operation</td> <td>ic</td> </tr> </tbody> </table> <p>the energy limitation refers to the minimum ignition energy of the substance, therefore intrinsically safe gas equipment is designed and manufactured for a specific group of gases.</p> <p>The protection level is obtained from the barrier protection level. The barrier can be of two types:</p> <ul style="list-style-type: none"> - Zener diode barrier: voltage limitation by means of Zener diodes parallel to the circuit and current limitation by means of resistors or fuses - Galvanic isolation barrier: isolated and energetically limited circuit <p>The associated electrical construction (barrier), when inside the dangerous area, must be protected by one or more protection modes, with a protection level (EPL) suitable for the classified area (e.g. by means of an Ex d enclosure if installed in zone 1)</p>	LEVEL OF PROTECTION (EPL)	CONDITIONS WHICH IMPEDE IGNITION	SYMBOL	Ga, Da	- normal operation, and with the application of two faults - normal operation, and with the application of one fault - normal operation	ia	Gb, Db	- normal operation, and with the application of one fault - normal operation	ib	Gc, Dc	- normal operation	ic	<p>Intrinsically safe protection is a system (circuit), which must be coordinated in order to prevent that sparks or energy released from have values that trigger the explosive atmosphere, both Gas (Group II) and dusts (Group III): a coordination document for each IS circuit is required, with:</p> <ul style="list-style-type: none"> - identification of the components (barrier, cables, junction boxes and field equipment, if any) - references to the barrier certificate and to that of the element in field (if it is not a "simple apparatus") - identification of the electrical output parameters of the barrier and input of the construction in field - identification of the concentrated parameters (C, L of output, input and of the various pieces of cable) - calculations of coordination and verification of intrinsic safety - circuit diagram for connecting the equipment <p>There are no particular conditions for the enclosures (minimum IP20), unless the installation or the intrinsically safe construction certificate requires a specific IP degree (for example, dust). They must be marked externally with the label "contains intrinsically safe circuits"</p> <p>The I.S. circuits MUST always be uniquely identified. Labels (TAGs) can be used, but if a colour is used, it must be light blue.</p> <p>The protection level of the intrinsically safe circuit is the lowest of one of the constructions which constitute the circuit (for example, a circuit with constructions of level "ib" and "ic" will have a protection level "ic")</p> <p>CABLES and CABLE INSTALLATION</p> <p>In intrinsically safe circuits, only cables whose test voltages of insulation of the conductor towards the ground, towards the shield and the one of the shield towards the ground, must be at least 500 V AC. or 750 V DC.</p> <p>Inside the place with risk of explosion, the diameter of the individual conductors or strings of stranded cables must not be less than 0.1 mm.</p> <p>Cables must be installed to ensure that intrinsically safe circuit cables cannot be inadvertently connected to circuit cables which are not intrinsically safe. I.S. And non-I.S. cables must be installed:</p> <ul style="list-style-type: none"> - in separate conduits (grounded if metal) - in the same conduit (grounded if metal) but one of the two cables (both are better) is reinforced, with metallic casing or protection - in separate sections of the same walkway (grounded if metal) <p>CABLES NOT USED</p> <ul style="list-style-type: none"> - insulated from the ground connected to a single unused terminal, on both sides, or - connected to the same grounding point as the i.s. circuit, typically the barrier ground bar <p>The standard establishes requirements for wiring inside the enclosure, regarding distances between I.S. and not-I.S. Circuits and towards grounded elements.</p> <p>The cables must be connected to the equipment according to the circuit diagrams which include information on how to connect the equipment, as envisaged in the certificate and/or instructions</p>	<p>EQUIPMENT</p> <ul style="list-style-type: none"> - presence of the descriptive document of the I.S. circuit - suitable documentation at the protection level/Zone - equipment installed as specified in the documentation (circuit diagram) - Installation clearly identified as in I.S., and each cable identified I.S., including the TAGs for the conductors connected to the equipment according to the wiring diagrams - No tampering - No modifications (internal components and enclosure) - Barriers correctly installed and earthed according to the standard requirements and the manufacturer/certificate instructions - Satisfactory housing conditions (IP required) - electrical connections tightened tightly, unused terminals tightened tightly <p>INSTALLATION</p> <ul style="list-style-type: none"> - cables installed according to documentation - unused cables connected as required by the standard - cable protections grounded in one point (or as per documentation) - cable armour grounded on both sides (instrument and panel) - no damage to cables - point-to-point connections according to the scheme - satisfactory grounding connections: where carried out (e.g. high integrity), cable insulation, minimum cable section, max resistance - separation between I.S. circuits and not - isolation distances - cable terminations as per documentation (terminals, insulation, etc.) 	<p>Advantages</p> <ul style="list-style-type: none"> - circuits can sparkle - low voltage system (<50 V), typically for instrumentation - No need for sealed cable entries - sometimes it does not require special IP requirements (if not from certificate or for dust) - often associated equipment (barrier) in an unclassified area within ordinary switchboards <p>ATTENTION:</p> <ul style="list-style-type: none"> - to uniquely identified circuits - to the presence of the circuit documentation (complete) - to a careful reading of the documentation and certificates - to choose of barrier coordinated with field equipment - to a coordinated level of protection - to take care of the installation of the cables inside the enclosures (insulation distances) and inside the conduits (separation) - to type of cable and maximum lengths allowed - to grounding connections (barriers, cable shields, cable armours) - if there are special conditions for safe use ("X" on the certificate and specific information in the documentation)
LEVEL OF PROTECTION (EPL)	CONDITIONS WHICH IMPEDE IGNITION	SYMBOL															
Ga, Da	- normal operation, and with the application of two faults - normal operation, and with the application of one fault - normal operation	ia															
Gb, Db	- normal operation, and with the application of one fault - normal operation	ib															
Gc, Dc	- normal operation	ic															

(continue)

Protection mode	IEC / EN standard	Main features	Installation requirements IEC EN 60079-14	Critical verification requirements IEC EN 60079-17	Contents				
i	60079-11	<p>Intrinsically safe equipment is generally equipped with a certificate, unless:</p> <ul style="list-style-type: none"> - it is a "simple apparatus" in compliance with the standard (passive apparatus, which does not accumulate active energy) - it has ic protection level (only for ATEX certification scheme), but in any case it must be accompanied by information on the input parameters. <p>The barriers are certified even if installed in an unclassified Zone.</p> <p>APPLICATIONS: Instrumentation, low power electronic devices.</p>	<p>GROUND AND EQUIPOTENTIAL CONNECTIONS</p> <p>Zener diode barriers require:</p> <ul style="list-style-type: none"> - a "high integrity earth connection": made with the connection to a ground bus in the electrical substation (main earth node) and not in the switchboard earth node - insulated ground conductor, and the resistance of the earth connection between the barrier ground bus and the main earth node must have $R \leq 1 \Omega$ - The conductors for the barrier ground connection must have a suitable cross section for carrying the fault current (one conductor $> 4 \text{ mm}^2$ or two insulated conductors $> 1.5 \text{ mm}^2$). <p>Galvanic barriers have no specific grounding requirement (always read the barrier's documentation if required by the certificate or instructions).</p> <p>The cable protections are grounded in a single point (or as required by the system documentation), typically in the switchboard in a safe area.</p> <p>The armours of the armoured cables must be connected to the potential equalization system through the cable entry devices, or with an equivalent system, at each end of the cable path</p> <p>VERIFICATION OF INTRINSICALLY SAFE CIRCUITS (only one barrier in the circuit)</p> <p>The conditions must be verified by examining the certificates:</p> <table border="1" data-bbox="673 1014 1011 1160"> <thead> <tr> <th data-bbox="673 1014 769 1059">Barrier</th> <th data-bbox="774 1014 1011 1059">Cables</th> </tr> </thead> <tbody> <tr> <td data-bbox="673 1066 769 1160"> $U_i \geq U_o$ $I_i \geq I_o$ $P_i \geq P_o$ </td> <td data-bbox="774 1066 1011 1160"> $C_i + C_c \times I \leq C_o$ $L_i + L_c \times I \leq L_o$ if $L_i + L_c \times I \geq L_o$ then $L_c/R_c \leq L_o/R_o$ </td> </tr> </tbody> </table> <p>Where the following suffixes mean: o: Barrier output i: input into the device in field c: cable</p>	Barrier	Cables	$U_i \geq U_o$ $I_i \geq I_o$ $P_i \geq P_o$	$C_i + C_c \times I \leq C_o$ $L_i + L_c \times I \leq L_o$ if $L_i + L_c \times I \geq L_o$ then $L_c/R_c \leq L_o/R_o$		
Barrier	Cables								
$U_i \geq U_o$ $I_i \geq I_o$ $P_i \geq P_o$	$C_i + C_c \times I \leq C_o$ $L_i + L_c \times I \leq L_o$ if $L_i + L_c \times I \geq L_o$ then $L_c/R_c \leq L_o/R_o$								

Guide to the ATEX directives

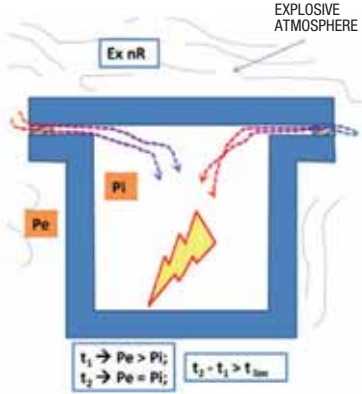
Protection mode	IEC / EN standard	Main features	Installation requirements IEC EN 60079-14	Critical verification requirements IEC EN 60079-17	Contents
nR	60079-15	<p style="text-align: right;">EXPLOSIVE ATMOSPHERE</p>  <p>FOR GAS ATMOSPHERES ONLY FOR SPARKLING AND NON-SPARKLING COMPONENTS PROTECTION LEVEL: - NORMAL "Gc" → ZONE 2 What does protection do? EXTERNAL ENCLOSURE</p> <p>The limited breathing equipment is built to limit heating during normal operation (ΔT limited to 20 K between enclosure and environment), so that the depression occurring when de-energized, is such as to delay the entry of explosive atmosphere for a time limit indicated by the standard (compatible with the definition of zone 2).</p> <p>INTERNAL COMPONENTS: standard</p> <p>ENCLOSURE</p> <ul style="list-style-type: none"> - if the components are sparking, a test point for field checks is required - The time in which the depression occurring when the equipment is de-energized returns to environmental pressure is obtained through the mechanical integrity of the enclosure and the seal by means of gaskets. These properties are verified through a breathing test (pressure) after: ageing (hot/cold), impact resistance (hot/cold), fall (if portable). Enclosure material not metallic or metallic. <p>CABLE ENTRIES: Marked with NR, or covered tested with the equipment and supplied by the equipment manufacturer.</p>	<p>Ex "nR" enclosures provided only with a component certificate, i.e. marked with the suffix "U", must not be installed in a dangerous place if they are not part of a set with Ex certificate of complete equipment: Taking an empty case and setting up a switchboard or junction box is NOT allowed.</p> <p>Additional holes or modifications to the entrances of an Ex "nR" appliance must be made only by the manufacturer. Installation of other components inside the enclosure is not allowed.</p> <p>The "nR" equipment must be installed in such a way that easy access to each test door is allowed. The equipment should be equipped with a test port to allow verification of the limited breathing properties limited following installation and during maintenance. See also the information provided in IEC 60079-15.</p> <p>The installation instructions supplied with the equipment containing information on the choice of both cable glands and entry cables or devices with protective tube must be complied with.</p> <p>The effects of heating caused by direct sunlight and other sources of heating or cooling on the enclosure should be taken into consideration.</p> <p>The use of a limited breathing enclosure as protection against ignition caused by sparking contacts is not recommended where, due to the high internal air temperatures, there is an increased risk of letting the explosive atmosphere in the enclosure when the equipment is not powered. A work cycle of this type of equipment should be considered due to the greater probability that the equipment may be de-energized when flammable gas or vapour surrounds the enclosure itself.</p> <p>CABLE ENTRIES: Marked with NR, or covered tested with the equipment and supplied by the equipment manufacturer.</p> <p>INTERNAL CONNECTIONS: In order to avoid the risk of short circuits between adjacent conductors in the terminal block, the insulation of each conductor must be maintained up to the metal part of the terminal. The manufacturer's instructions on cable terminations must be complied with (e.g. tube lug, fork lug, etc.) in order to keep the temperatures limited. A greater number of 6 conductors, in bundles, can also cause temperatures so high as to exceed class T6 and/or damage the insulation and, therefore, should be avoided.</p>	<ul style="list-style-type: none"> - No tampering - No modifications (internal components and enclosure) - No damage on the enclosure - No damage to the seals on which the enclosure depends - No damage to cables and conductors - Check the wiring (internal filling of the enclosure with bundles of conductors) and terminations (internal T increase) - Cable glands, caps, bolts of the correct type (also check the Gas Group) and tightened as per instructions - Tightening electrical connections and checking the terminals - Tightening the unused terminals to the bottom - Grounding of insulated metal parts (metal cable glands and cable armours) - Verification of adequate protections against external atmospheric agents (corrosion, vibrations, etc.) 	<p>Advantages</p> <ul style="list-style-type: none"> - standard components, also sparking <p>ATTENTION:</p> <ul style="list-style-type: none"> - Thermal limitation: the use must be rigorous both in terms of ratings and in terms of the type of component: the replacement of an internal component (even if standard) cannot take place with the same electrical characteristics, but it must be a spare part, being related to the temperature tests for which compliance with the protection mode is guaranteed - take the work cycle of the equipment into account, in order not to affect the thermal limitation - installation conditions can increase the internal air temperature <p>ENCLOSURE</p> <p>The enclosure must be periodically and often checked.</p> <ul style="list-style-type: none"> - Field breathing test, whose frequency is decided according to the environmental conditions of installation. <p>The protection given by the seals must be verified in service: the focus is not on the IP degree, but on the sealing obtained.</p> <p>Attention must be paid to:</p> <ul style="list-style-type: none"> - all elements with gaskets (including caps, cable glands, flanges and covers of the enclosure) which are not loose - to tightening torques - environmental conditions: vibrations, impacts, extreme conditions - not to pile cables inside the enclosures (increase in temperatures). At most 6 conductor bundles - do not lose bolts - to cable entries: choice of cable gland - if there are special conditions for safe use ("X" on the certificate and specific information in the documentation)

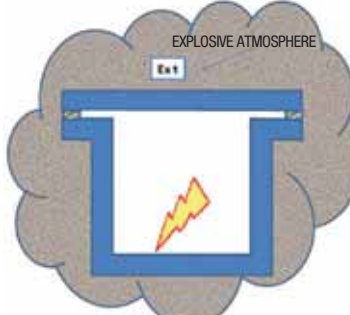
Protection mode	IEC / EN standard	Main features	Installation requirements IEC EN 60079-14	Critical verification requirements IEC EN 60079-17	Contents																
t	60079-31	 <p>FOR DUST ATMOSPHERES ONLY SPARKLING and NON-SPARKLING COMPONENTS PROTECTION LEVEL: - VERY HIGH "Da" → ZONE 20 - HIGH "Db" → ZONE 21 - NORMAL "Dc" → ZONE 22</p> <p>What does protection do? EXTERNAL ENCLOSURE - enclosures containing electrical equipment, in which the entry of an explosive atmosphere is prevented; - equipment and components inside the enclosure can be standard; - protection level Da, Db or Dc, according to the requirements which the enclosure meets; - for all protection levels, specific characteristics are required on the joints, cable entries, manoeuvring rods, etc. and with respect to all parts of the interface enclosure with the outside, in order to maintain protection against the entry of dust; - for the Da protection level, additional requirements are set to limit the maximum surface temperature; - The protection levels are achieved through protection against the entry of dust, verified by IP protection degree requirements, determined after subjecting the enclosure to the following tests: ageing (hot/cold), impact resistance (hot/cold), fall (if portable), a pressure test.</p> <p>The minimum degree of protection is prescribed in relation to the group of dusts:</p> <table border="1" data-bbox="287 1400 638 1523"> <thead> <tr> <th>Level of protection</th> <th>Group IIIC</th> <th>Group IIIB</th> <th>Group IIIA</th> </tr> </thead> <tbody> <tr> <td>"ta"</td> <td>IP6X</td> <td>IP6X</td> <td>IP6X</td> </tr> <tr> <td>"tb"</td> <td>IP6X</td> <td>IP6X</td> <td>IP5X</td> </tr> <tr> <td>"tc"</td> <td>IP6X</td> <td>IP5X</td> <td>IP5X</td> </tr> </tbody> </table>	Level of protection	Group IIIC	Group IIIB	Group IIIA	"ta"	IP6X	IP6X	IP6X	"tb"	IP6X	IP6X	IP5X	"tc"	IP6X	IP5X	IP5X	<p>Ex "t" enclosures provided only with a component certificate, i.e. marked with the suffix "U", must not be installed in a dangerous place if they are not part of a set with Ex certificate of complete equipment: Taking an empty case and setting up a switchboard or junction box is NOT allowed.</p> <p>Additional holes or modifications to the entrances of an Ex "t" appliance must be made only by the manufacturer. Installation of other components inside the enclosure is not allowed.</p> <p>Requirements for limiting the temperature, especially to guarantee the disposal of the heat produced by the power dissipated inside the enclosure, in order to prevent the temperature from exceeding the temperature class of the equipment.</p> <p>The length of the conductors inside the enclosure should be kept as short as possible as a basis for the calculation and not greater than the length of the diagonal of the enclosure. Fully tighten unused terminals.</p> <p>The manufacturer's documentation contains information on: - size of the conductor - maximum current - maximum number of conductors for each connection point (the standard requires 1, but it depends on the certificate) - preparation of cable terminations: type of terminals, stripping length, etc. - terminal tightening torque - tightening torque of the enclosure screws</p> <p>CABLE ENTRIES "t" certified plugs for the same Gas Group as the appliance.</p> <p>It is possible to use a cable gland ONLY if marked with "t" for the degree of protection of the construction certificate with the minimum IP corresponding to the level of protection</p>	<ul style="list-style-type: none"> - No tampering - No modifications (internal components and enclosure) - No damage on the enclosure - No damage to the seals on which the enclosure depends - No damage to cables and conductors - Minimum degree of protection IP (the one in the certificate) maintained during installation - Minimum degree of protection IP (the one in the certificate) maintained in the assembly of the entrances in the enclosure - Cable glands, caps, bolts of the correct type (also check the Dust Group) and tightened as per instructions - Tightening electrical connections and checking the terminals - Tightening the unused terminals to the bottom - Grounding of insulated metal parts (metal cable glands and cable armours) - Verification of adequate protections against external atmospheric agents (corrosion, vibrations, etc.) 	<p>Advantages</p> <ul style="list-style-type: none"> - Protection against ignition assigned to the IP5X or IP6X protection degree only - No need for sealed cable entries <p>ATTENTION:</p> <ul style="list-style-type: none"> - do not damage the thermal part with use outside the ratings or with the addition of components - to tightening torques - to correct cable preparation - do not pile cables inside the enclosures - do not lose bolts - to cable entries: choice of cable gland - to cable gland preparation for armoured cable - to equipotentiality on cable entries - to maintenance of IP degree - if there are special conditions for safe use ("X" on the certificate and specific information in the documentation)
Level of protection	Group IIIC	Group IIIB	Group IIIA																		
"ta"	IP6X	IP6X	IP6X																		
"tb"	IP6X	IP6X	IP5X																		
"tc"	IP6X	IP5X	IP5X																		

Protection mode	IEC / EN standard	PROTECTION LEVEL (on the certificate or EU declaration of conformity)	PROTECTION MODE	INSTALLATION IN THE AREA ALLOWED
d	60079-1	Ga	da	ZONE 0
		Gb	db	ZONE 1
		Gc	dc	ZONE 2
e	60079-7	Gb	eb	ZONE 1
		Gc	ec	ZONE 2
i	60079-11	Ga, Da	ia	ZONE 0, ZONE 20
		Gb, Db	ib	ZONE 1, ZONE 21
		Gc, Dc	ic	ZONE 2, ZONE 22
n	60079-15	Gc	nC, nR	ZONE 2
t	60079-31	Da	ta	ZONE 20
		Db	tb	ZONE 21
		Dc	tc	ZONE 22

The IEC EN 60079-14 standard (design, choice and construction of the electrical system) sets the safety requirements for each protection mode. A piece of equipment can also be created with compound protection modes, for example a "d" enclosure with an "e" terminal block. In this case, both "d" and "e" letters will be present in alphabetical order. As far as the installation rules are concerned, the requirements of both protection modes apply.

Guide to the ATEX directives

6. IEC SYSTEM AND LEGISLATION: ATEX DIRECTIVES

The European Union legislation on equipment, components, assemblies and protection systems intended for use in zoned with explosion risk refers to electrical equipment by adopting the approach of the IEC Zone System.

In this scheme, the technical standards IEC 60079 harmonized by the European Union as EN 60079 standards acquire "presumption of conformity" with the essential safety requirements of European legislation and constitute technical reference for the countries of the Union.

The legislation is also summarized below with reference also to the ATEX product directive 94/9/EC, now repealed and replaced by Directive 2014/34/EU, but which first introduced the classification of equipment as used also in the new Directive.

INTRODUCTION

What is ATEX?

ATEX is an abbreviation for "ATmosphere EXplosible", or explosive atmosphere.

An explosive atmosphere is a mixture of dangerous substances with air, under atmospheric conditions, in the form of gases, vapours, mist or dust in which, after ignition has occurred, combustion spreads to the entire unburned mixture.

A potentially explosive atmosphere occurs when the flammable substance must be present in a certain concentration; if the concentration is too low (poor mixture) or too high (rich mixture) no explosion occurs, only a combustion reaction occurs, sometimes not even a reaction.

The explosion can therefore only occur in the presence of an ignition source and when the concentration is within the explosive range of the substances, between the minimum (LEL) and maximum (UEL) explosive limits. Explosive limits depend on the pressure of the environment and the percentage of oxygen present in the air.

ATEX DIRECTIVES

The European Union, in the context of the risk due to the presence of potentially explosive atmospheres, has adopted two harmonised health and safety directives, known as ATEX 94/9/EC (also ATEX 100a, which from 20 April 2016 onwards was replaced by the new directive 2014/34/EU) and ATEX 99/92/EC (also ATEX 137).

ATEX directive 94/9/EC establishes the **Essential Safety Requirements** for products and protection systems intended for use in potentially explosive atmospheres and the related compliance procedures. ATEX directive 99/92/EC, on the other hand, defines the **minimum health and safety requirements on the workplace** with the presence of potentially explosive atmospheres; in particular, it subdivides them into zones, according to their probability of the presence of an explosive atmosphere and specifies the criteria according to which the products are chosen within said zones. ATEX directive 94/9/EC has been implemented in Italy with Legislative Decree 126/98 and applies to products which entered the market and/or in service since 1 July 2003. ATEX directive 99/92/EC was implemented in Italy with Legislative Decree 233/03, which entered into force on 10 September 2003. The subsequent Legislative Decree 81/08 dated 9 April 2008 (in particular title XI - Protection from explosive atmospheres) and its update (Legislative Decree 106/2009 dated 3/08/09, in force since 20 August) then passed Legislative Decree 233/03. The figure shows a scheme of the ATEX Directives and their correlation.

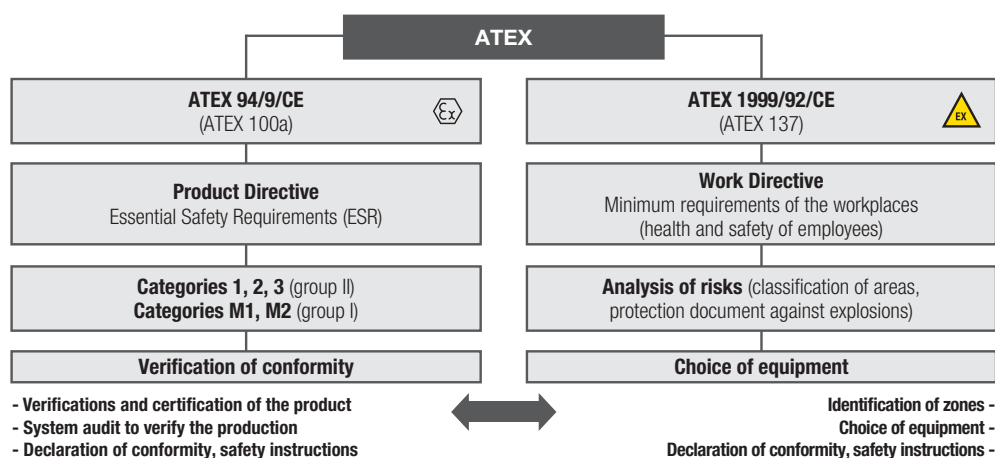

NEW ATEX PRODUCT DIRECTIVE: 2014/34/EU (former Directive 94/9/EC)

On 29 March 2014, the new ATEX directive 2014/34/EU was published which repealed, with effect from 20 April 2016, ATEX directive 94/9/EC.

The revision of the directive does not introduce substantial changes compared to the previous one, but it gives greater importance to the obligations of the various operators in the supply chain, such as manufacturers, authorised representatives, importers and distributors.

Products and equipment placed on the market which comply with the previous directive may continue to be marketed on the EU territory even after the effective date as long as they comply with the harmonised technical standards in force at that time (indicated in the declaration of conformity of the product). Since 20 April 2016 onwards, the declarations of conformity of the products have been mandatory in compliance with the new directive 2014/34/EU.

ATEX 94/9/EC DIRECTIVE: PRODUCTS

The ATEX directive entered into force on 1 July 2003 throughout the European Union and replaces the different national and European legislation existing in the field of explosive atmospheres; since that date, it has been possible to market only products which comply with the directive and have the CE ATEX marking and declaration of conformity.

It applies to all products, both electrical and mechanical, intended for places with risk of explosion and is among the directives which allow the free movement of goods and define the essential safety requirements (ESR) of the products envisaged.

In particular, the directive defines the categories of products and the features they must satisfy in order to be installed in places where there is a risk of explosion; it also describes the procedures to follow to achieve compliance.

The scope of the Directive also extends to safety, control and regulation devices which are installed outside of potentially explosive air, but on which the safety of products installed in an explosive atmosphere depends.

CLASSIFICATION OF EQUIPMENT (IDENTICAL TO DIRECTIVE 2014/34/EU)

The directive includes surface and mining equipment, because hazard, protective measures and test methods are similar for both types of product; the first distinction is made by dividing it into two groups:

- group I: products to be used in grisou mines;
- group II: equipment intended for use on the surface. Directive 94/9/EC classifies products into categories, in relation to the level of protection and according to the degree of dangerousness of the environment where they will be inserted.

PRODUCT GROUP I

Mine products are divided into 2 categories:

M1 category: equipment or protection systems which guarantee a very high level of protection;

M2 category: equipment or protection systems which guarantee a high level of protection; one must be able to disconnect them in the presence of gas.

PRODUCT GROUP II

Surface equipment (group II) are divided into 3 categories, according to the level of protection (area of use); the categories are identified by the number 1, 2, 3 followed by letter G (Gas) or D (Dust).

- **category 1:** equipment or protection systems which guarantee a very high level of protection;
- **category 2:** equipment or protection systems which guarantee a high level of protection;
- **category 3:** equipment or protection systems which guarantee a normal level of protection.

CLASSIFICATION OF EQUIPMENT IN ATEX DIRECTIVE Vs IEC/EN 60079 STANDARDS

Protection levels (EPL) in compliance with IEC 60079 classification				ATEX classification	
ATMOSPHERE	EPL	PROTECTION LEVEL	INSTALLATION AREA	GROUP	CATEGORY
MINE GAS GROUP I	Ma	VERY HIGH	--	I	Ma
	Mb	HIGH	--		Mb
SURFACE GAS GROUP IIA, IIB, IIC	Ga	VERY HIGH	ZONE 0	II	1G
	Gb	HIGH	ZONE 1		2G
	Gc	NORMAL	ZONE 2		3G
COMBUSTIBLE DUST GROUP IIIA, IIIB, IIIC	Da	VERY HIGH	ZONE 20		1D
	Db	HIGH	ZONE 21		2D
	Dc	NORMAL	ZONE 22		3D

COMPLIANCE PROCEDURES (IDENTICAL TO DIRECTIVE 2014/34/EU)

For the purposes of marking, various compliance procedures are provided according to the product and the category to which it belongs. All **category 1 and category 2 electrical equipment** must be **certified ("EC Type Examination", which in Directive 2014/34 / EU takes the name of "EU type examination")** by **ATEX Notified Bodies**, also Notified Body, i.e. the Bodies to which the national authority has entrusted the task of verifying compliance with the directive (in Italy, for example: IMQ, CESI, ICEPI, TUV, etc.). The updated list of ATEX Notified Bodies (ExNB) is available on the website: <http://ec.europa.eu/enterprise/newapproach/nando/>

Companies that produce category 1 and category 2 electrical appliances, are obliged to notify and monitor the quality system via NB ATEX; the organisation's identification number is affixed to the plate together with the CE marking.

Self-certification is envisaged for all category 3 equipment, with internal manufacturing control; in the case of SCAME, the manufacturing control is satisfied by the company quality certification ISO 9001: 2008, released by CSQ.

The manufacturer must prepare the technical documentation which demonstrates the compliance of the equipment with the requirements of the Directive; the documentation must remain available for at least 10 years from the last release on the market.

All products (categories 1, 2 and 3) must be accompanied by the EC declaration of conformity (called "EU declaration of conformity" in Directive 2014/34/EU) as well as by the safety and use instructions.

The following table shows the type of certification required according to the category of products.

PRODUCT CATEGORY	EPL	CERTIFICATION OF PRODUCT BY NB	CERTIFICATION OF COMPANY BY NB	SELF-CERTIFICATION	DECLARATION OF CONFORMITY AND INSTRUCTION MANUAL
M1	Ma	YES	YES	NO	YES
M2	Mb	YES	YES	NO	YES
1G	Ga	YES	YES	NO	YES
1D	Da	YES	YES	NO	YES
2G	Gb	YES	YES	NO	YES
2D	Db	YES	YES	NO	YES
3G	Gc	Elective	NO	YES	YES
3D	Dc	Elective	NO	YES	YES

Guide to the ATEX directives

MARKING



The products must be equipped with the appropriate identification plate which must have, in addition to the CE marking, the specific marking of explosive protection (**Epsilon-x**, in the hexagon) followed by the **group** (I or II) and **category**; for **group II**, the letter **G** is added for equipment for Gas while equipment for dust is identified by the letter **D** (Dust).

In addition to the data required by the ATEX Directive, the plate must also indicate the type of protection as provided for by the standard and the information useful for correct identification and use of the product.

The table below specifies the main information provided on the product plates with relative explanatory notes and their meaning, with reference to the symbol numbers on the example plate.

Marking example

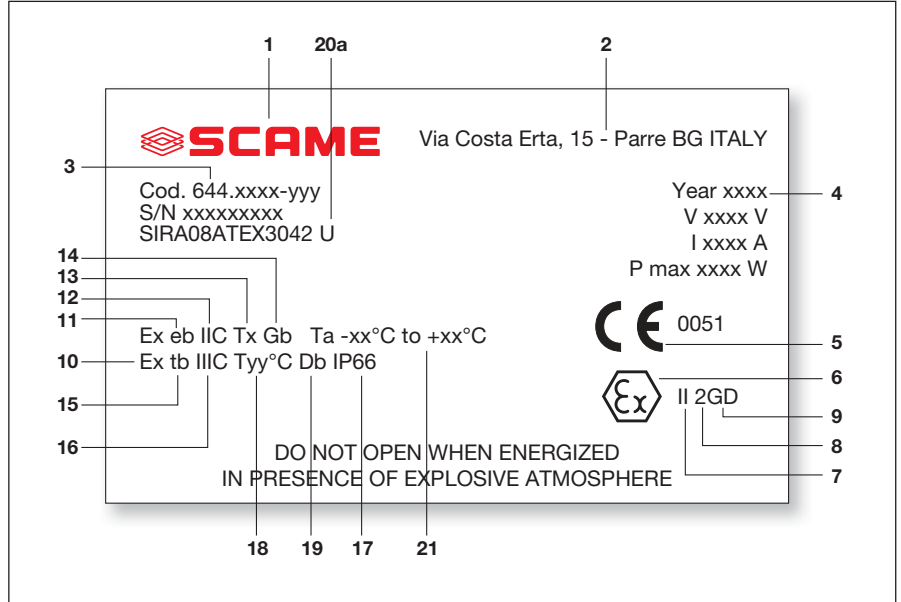

General information

N°	Marking	Meaning	Variants
1	SCAME	Manufacturer	-
2	Via Costa Erta 15 PARRE (BG) – ITALY	Manufacturer's address	-
3	Cod. 644.xxx-yyy	Product designation	-
4	2015	Year of manufacture	-
5	CE	Conformity mark	For categories 1 and 2 it must be followed by the number of the notified body (*)
6	Epsilon-x	Specific marking of explosive protection	-
7	II	Equipment group	I: electrical equipment for mines II: electrical equipment for surface installations
8	2	Product category	1 for category 1 2 for category 2 3 for category 3
9	GD	Type of explosive atmosphere	G: gas / D: dust / GD: gas and dust

(*) Number (4-digit number) of the notified body responsible for ATEX company monitoring (for example: the number 0051 corresponds to IMQ, the number 0722 corresponds to CESI, etc.).

Gas (specific information)

N°	Marking	Meaning	Variants
10	Ex	Prefix of the types of protection for electrical equipment	-
11	e	Type of protection applied	Types of protection for GAS: - "d": explosion-proof enclosure - "e": increased safety - "ia" or "ib" or "ic": intrinsic safety, level of protection "ia" or "ib" or "ic" - "ma", "mb" or "mc": encapsulation, level of protection "ma" or "mb" - "nA": type of protection "nA" - "nC": type of protection "nC" - "nR": type of protection "nR" - "o": oil immersion - "px" or "py" or "pz": pressurized apparatus, level of protection "px" or "py" or "pz" - "q": powder filling
12	IIC	Flammable gas group	Group to which the flammable gas present on the installation belongs: IIA, IIB or IIC
13	Tx	Temperature class = maximum temperature that the electrical equipment can reach	Temperature class (Group II): T1 = 450°C T2 = 300°C T3 = 200°C T4 = 130°C T5 = 100°C T6 = 85°C
14	Gb	EPL Gas	Gas equipment protection level (EPL): Ga: very high (suited for zone 0) Gb: high (suited for zone 1) Gc: increased (suited for zone 2)

Dust (specific information)

N°	Marking	Meaning	Variants
15	tb	Type of protection applied	Types of protection for dust: - "ta", "tb" or "tc": protection by enclosure - "ia", "ib" or "ic": intrinsic safety protection - "ma", "mb" or "mc": protection with encapsulation - "px" or "py" or "pz": protection with pressurized enclosures, level of protection "px" or "py" or "pz"
16	IIIC	Group of combustible dust	Group to which the combustible dust present on the installation belongs: IIIA: fibres IIIB: non-conductive dust IIIC: conductive dust
17	IP66	Degree of protection (IP)	IP6X: apparatus suitable for Zone 22 with the presence of conductive dust IP5X: apparatus suitable for Zone 22 with the presence of non-conductive dust
18	Tyy°C	Maximum surface temperature that the electrical equipment can reach	Tyy°C: maximum surface temperature of the equipment expressed in °C
19	Db	EPL Dust	Combustible dust equipment protection level (EPL): Da: very high (suited for zone 20) Db: high (suited for zone 21) Dc: increased (suited for zone 22)

Additional Information

N°	Marking	Meaning	Variants
20a	U	Indicates the ATEX components	"U": indicates an EX component
20b	X	Particular additional information	"X": indicates the presence of special conditions for safe use (to be checked on the certificate or in the instructions for use)
21	Ta -xx°C to +xx°C	Ambient temperature range	If not indicated, the range is: -20°C +40°C

Guide to the ATEX directives

7. EX WORLD GEOGRAPHY

In order to circulate in the European Union, a product intended to be installed in an explosive atmosphere MUST bear the ATEX mark in compliance with Directive 2014/34/EU whose compliance procedures are described in the previous paragraphs.

When is a product destined for non-European countries?

At global level, there are mainly two regions with two different approaches, in terms of area classification, equipment classification, protection techniques and installation requirements.

The first "region" is made up of the co-participating IEC countries (including European Union countries), in which there are local laws for each country, but if the product is certified in compliance with the IEC scheme for hazardous areas (IECEx Certification) it is possible to "transfer" the certification into a certificate pursuant to the law/regulation of that country.

The IECEx certification scheme is relative to the verification of compliance with the IEC 60079 series of standards and is a voluntary certification scheme, however, the fact that it is an "open" system or that documents are available to everyone on the scheme portal makes it usable for conversion to "local" certification.

IECEx CERTIFICATION SCHEME

The scheme is in fact based on the IEC Zone System scheme described in these pages, with the following certification procedures.

All electrical **equipment with EPL Ga, Da, Gb, Db, Gc and Dc** must be **certified ("Certificate of Conformity - IECEx CoC") by IECEx Certification Bodies (ExCB)**. The updated list of ExCB Certification Bodies is available on the website: <http://iecex.com/>

The difference from the ATEX directive is that the products for Zone 2 and Zone 22 are also certified by a third-party body: there is no self-certification. The scheme is based on 3 procedures leading to the issuance of the following 3 documents:

IECEx CoC	IECEx Certificate of Conformity	- Assessment of conformity of the project in compliance with the IEC 60079 standard of reference for the way of protection of the equipment. It is based on the IECEx TR
IECEx TR	Test Report of the type tests	- Type tests in compliance with IEC 60079 of reference
IECEx QAR	Quality Assessment Report	- Assessment report of the quality management system, which must ensure that all products are made in compliance with the project. It is based on the IEC 80079-34 standard, for quality management systems for the production of Ex products.

AMERICAN SCHEME - HAZARDOUS LOCATIONS

The second "world region" that we consider is NORTH AMERICA (USA and CANADA), where historically a method of classification of areas and products has developed parallel to the IEC Zone System, but based on a different approach. The regulation that sets requirements for products and installations in hazardous areas in the USA is NFPA 70 (National Fire Protection Association # 70), also known as NEC (National Electrical Code). The NEC is approved as an "American National Standard" by ANSI (American National Standard Institute) as ANSI/NFPA 70.

The NEC is also accepted and published in CANADA by the Canadian Standard Association (CSA) as Canadian Electrical Code **CSA C22.1**.

The NEC not only provides prescriptions for hazardous areas, but it sets the requirements for all electrical equipment and electrical systems, with a focus on electrical safety and fire protection. For this reason, it is always required that a product intended to be installed in a hazardous area (Hazardous Location) primarily meets the requirements for ordinary places to which, unlike the European system, it cannot be declared compliant by means of self-certification, but it must be verified by a certification body recognised by the system.

The bodies accredited to issue a certification in accordance with the NEC (both for the USA and Canada), can be different, among the best known are: UL (Underwriters Laboratories), CSA, FM (Factory Mutuals), INTERTEK, etc.

In essence, the product is required to be "listed" if it is an equipment or "recognized" if it is a component, by one of these bodies, in accordance with the requirements of the NEC for the specific place where it is intended: ordinary (i.e. not dangerous) or dangerous (hazardous locations).

The NEC is structured in chapters: from chapter 1 to chapter 4, the requirements for products and systems (e.g. pipes, entries in enclosures, etc.) for ordinary places are set. Chapters 5 to 7 modify and/or extend the ordinary requirements for equipment intended for hazardous locations. In particular, articles 500 to 506 of Chapter 5 deal with explosive atmospheres.

ARTICLE 500 OF NEC

Article 500 of Chapter 5 deals with the "Hazardous Locations", intended as areas with risk of explosion which are divided as follows:

- Subdivision into 3 classes according to the type of explosive atmosphere
 - Class I (gas, vapours, combustible mists)
 - Class II (dusts)
 - Class III (combustible fibres)
- Each class is divided into two types of explosion hazard areas according to the frequency or duration of the formation of an explosive atmosphere
 - Division 1
 - Division 2

The following tables show the descriptions of the classified areas.

GAS, VAPOURS, COMBUSTIBLE MISTS	
CLASS I	
Areas where gas, vapours or combustible mists are or may be present in sufficient quantity to produce explosive or ignitable mixtures	
DIVISION 1	DIVISION 2
EXPLOSIVE CONCENTRATION DURING NORMAL OPERATIONS EXPLOSIVE CONCENTRATION FREQUENTLY PRESENT IN CASE OF MAINTENANCE/REPAIR OR IN CASE OF DRAWING THE BREAKING OF A APPLIANCE OR A PROCESS MAY RELEASE EXPLOSIVE CONCENTRATION AND HAVE A CONTEMPORARY FAILURE IN ELECTRICAL EQUIPMENT, WHICH CAN CAUSE IT TO BECOME AN IGNITION SOURCE	THE SUBSTANCES ARE CONFINED IN CONTAINMENT SYSTEMS AND CAN ONLY EXIT IN THE EVENT OF FAILURE EXPLOSIVE CONCENTRATION PREVENTED BY A VENTILATION SYSTEM. THE DANGEROUS AREA CAN FORM AS A RESULT OF A BREAKDOWN OF THE VENTILATION SYSTEM EXPLOSIVE CONCENTRATION DUE TO AREAS NEXT TO DIVISION 1, WITHOUT PREVENTION BY PRESSURISATION OR VENTILATION

COMBUSTIBLE DUST	
CLASS II	
Areas at risk of explosion for the presence of combustible dusts	
DIVISION 1	DIVISION 2
DUST PRESENT IN EXPLOSIVE CONCENTRATION DURING NORMAL OPERATIONS THE BREAKING OR FAULT CONDITIONS OF AN APPLIANCE OR MACHINE MAY RELEASE DUST IN EXPLOSIVE CONCENTRATION AND HAVE A CONTEMPORARY FAILURE IN ELECTRICAL EQUIPMENT, WHICH CAN CAUSE IT TO BECOME AN IGNITION SOURCE PRESENCE OF METALLIC DUSTS SUCH AS ALUMINUM AND MAGNESIUM (GROUP E), IN A DANGEROUS QUANTITY	PRESENCE OF COMBUSTIBLE DUST IN AIR, IN CONSEQUENCE OF A FAULT AND IN QUANTITY WHICH CAUSES AN EXPLOSIVE CONCENTRATION LAYERS OF DUST ARE PRESENT, BUT THEY ARE NORMALLY INSUFFICIENT TO INTERFERE WITH THE NORMAL OPERATION OF THE EQUIPMENT; HOWEVER, THEY COULD BE LIFTED IN CASE OF MALFUNCTION AND ORIGINATE EXPLOSIVE CONCENTRATION LAYERS OF DUST IN THE SURROUNDINGS OR DEPOSITED ON THE EQUIPMENT WHICH MAY CHANGE THE DISSIPATION CAPACITY AND IGNITE

COMBUSTIBLE FIBERS	
CLASS III	
Hazardous environments due to the presence of easily ignitable fibres or where materials producing volatile fuel are used, but in which these fibres are not likely to be present in sufficient quantities to create an explosive mixture	
DIVISION 1	DIVISION 2
ENVIRONMENTS IN WHICH EASILY IGNITABLE FIBERS ARE HANDLED, PRODUCED OR USED	ENVIRONMENTS IN WHICH THEY ARE STORED OR HANDLED NOT IN THE PRODUCTION PROCESS EASILY IGNITABLE FIBERS

Even art. 500 divides substances into groups (and therefore also equipment).

CLASS I Classification in Groups

Unlike the IEC Zone System, it considers Acetylene and Hydrogen separately by assigning it to two separate groups. Another difference is the reverse order of hazard. In the IEC system the gas hazard is increasing from Group A to Group C (Hydrogen and Acetylene). The division into groups of the NEC 500, on the other hand, confers the hazard in reverse or decreasing order from Group A (Acetylene) to Group D.

CLASS	GROUP	EQUIPMENT FOR
CLASS I	A	ACETYLENE
	B	HYDROGEN MSEG ≤ 0,45 mm MIC ≤ 0,40
	C	ETHYLENE 0,45 mm < MSEG ≤ 0,75 mm 0,40 < MIC ≤ 0,80
	D	PROPANE MSEG > 0,75 mm MIC > 0,80

CLASS II and CLASS III Classification in Groups

Unlike the IEC system, in which Group III of dusts, with the exception of fibres, is divided into conductive and non-conductive powders, the NEC 500 divides the powders into 3 groups.

Fibres constitute Class III, which is not divided into groups.

CLASS	GROUP	EQUIPMENT FOR
CLASS II	E	METALLIC COMBUSTIBLE DUSTS, INCLUDING ALUMINIUM, MAGNESIUM AND THEIR COMMERCIAL ALLOYS, OR OTHER COMBUSTIBLE DUSTS OF PARTICULAR DIMENSIONS, ABRASIVITY AND CONDUCTIVITY WHICH PRESENT SIMILAR RISK IN ELECTRICAL USES
	F	VOLATILE CARBON-BASED COMBUSTIBLE DUSTS IN A PERCENTAGE OF MORE THAN 8% TOTAL, OR WHICH HAVE BEEN SENSITISED BY OTHER MATERIALS
	G	DUSTS NOT INCLUDED IN THE E AND F GROUPS, INCLUDING FLOWER, WHEAT, WOOD, PLASTIC AND CHEMICAL DUSTS
CLASS III	-	COMBUSTIBLE FIBERS

Guide to the ATEX directives

Protection techniques

Article 500.7 defines the accepted protection techniques for the classification of Hazardous Locations in Classes and Divisions. These are close to the protection techniques of the IEC system protection modes, but in reality they have very different design and test requirements (more compelling in the case of DIVISION 1) and therefore cannot be superimposed. IEC 60079 protection techniques are instead applicable to the classification of areas in accordance with articles NEC 505 and 506 (see below).

CLASSIFICATION OF PRODUCTS IN RELATION TO THE MAXIMUM SURFACE TEMPERATURE

Article 500 requires that the maximum surface temperature is indicated on the marking. The equipment is divided into classes like in the IEC system (based on six classes from T1 to T6), but intermediate "subclasses" are added between one class and another. The following table shows the classification in temperature classes referring to the maximum surface temperature of the equipment. In the last column, the comparison with the classes of the IEC system is shown.

MAXIMUM SURFACE TEMPERATURE (OC)	NEC TEMPERATURE CLASS	IEC TEMPERATURE CLASS
450	T1	T1
300	T2	T2
280	T2A	-
260	T2B	-
230	T2C	-
215	T2D	-
200	T3	T3
180	T3A	-
165	T3B	-
160	T3C	-
135	T4	T4
120	T4A	-
100	T5	T5
85	T6	T6

EXAMPLE OF NEC ART. MARKING 500.....

The marking of a product for Hazardous Locations, in addition to the certification body's mark and the product information (manufacturer, manufacturer's address, product name, serial number, electrical ratings, etc.), contains the following information:

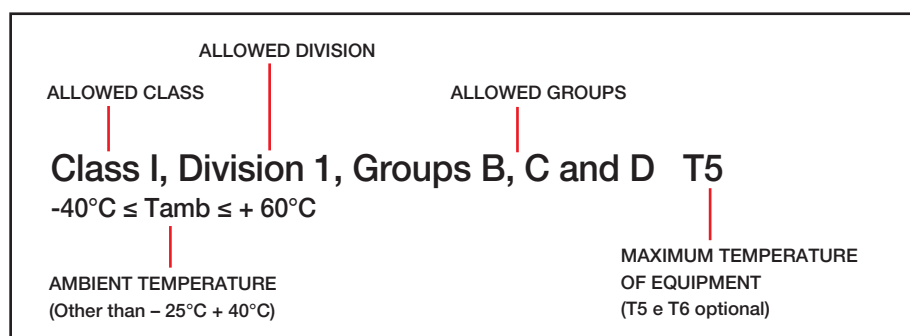

In addition, optionally and with the exception of "intrinsic safety" (I.S.), the protection technique can be used (e.g. "explosion proof").

ARTICLES 505 AND 506 OF NEC

Since the USA and CANADA also share articles 505 and 506 with IEC, they essentially adopt the IEC Zone System, i.e. the classification of hazardous areas in Zones and the IEC classification of equipment. However, some historical differences between the two worlds persist and the following differences occur.

GAS – ART. 505	DUST - ART. 506																																									
<p>Classification of the Areas (CLASS I REMAINS)</p> <table border="1" style="margin: auto; border-collapse: collapse;"> <tr><td style="padding: 2px 10px;">CLASS I</td><td style="padding: 2px 10px;">ZONE 0</td></tr> <tr><td style="padding: 2px 10px;">CLASS I</td><td style="padding: 2px 10px;">ZONE 1</td></tr> <tr><td style="padding: 2px 10px;">CLASS I</td><td style="padding: 2px 10px;">ZONE 2</td></tr> </table> <p>Classification of the Equipment in Groups</p> <table border="1" style="margin: auto; border-collapse: collapse;"> <tr><td style="padding: 2px 10px;">Group IIA</td></tr> <tr><td style="padding: 2px 10px;">Group IIB</td></tr> <tr><td style="padding: 2px 10px;">Group IIC</td></tr> </table> <p>Comparison with art. 500</p> <table border="1" style="margin: auto; border-collapse: collapse;"> <tr><td style="padding: 2px 10px;">Group IIA</td><td style="padding: 2px 10px;">Group D</td></tr> <tr><td style="padding: 2px 10px;">Group IIB</td><td style="padding: 2px 10px;">Group C</td></tr> <tr><td style="padding: 2px 10px;">Group IIC</td><td style="padding: 2px 10px;">Groups B and A</td></tr> </table> <p>Classification of the equipment by temperature classes</p> <table border="1" style="margin: auto; border-collapse: collapse;"> <thead> <tr> <th style="padding: 2px 10px;">TEMPERATURE CLASS</th> <th style="padding: 2px 10px;">MAXIMUM SURFACE T</th> </tr> </thead> <tbody> <tr><td style="padding: 2px 10px;">T1</td><td style="padding: 2px 10px;">450 °C</td></tr> <tr><td style="padding: 2px 10px;">T2</td><td style="padding: 2px 10px;">300 °C</td></tr> <tr><td style="padding: 2px 10px;">T3</td><td style="padding: 2px 10px;">200 °C</td></tr> <tr><td style="padding: 2px 10px;">T4</td><td style="padding: 2px 10px;">135 °C</td></tr> <tr><td style="padding: 2px 10px;">T5</td><td style="padding: 2px 10px;">100 °C</td></tr> <tr><td style="padding: 2px 10px;">T6</td><td style="padding: 2px 10px;">85 °C</td></tr> </tbody> </table> <p>Marking IEC construction for NEC takes the prefix "AEx"</p> <p style="text-align: center;">Class I, Zone 0 AEx ia IIB T6</p>	CLASS I	ZONE 0	CLASS I	ZONE 1	CLASS I	ZONE 2	Group IIA	Group IIB	Group IIC	Group IIA	Group D	Group IIB	Group C	Group IIC	Groups B and A	TEMPERATURE CLASS	MAXIMUM SURFACE T	T1	450 °C	T2	300 °C	T3	200 °C	T4	135 °C	T5	100 °C	T6	85 °C	<p>Classification of the Areas (CLASS II DISAPPEARS)</p> <table border="1" style="margin: auto; border-collapse: collapse;"> <tr><td style="padding: 2px 10px;">ZONE 20</td></tr> <tr><td style="padding: 2px 10px;">ZONE 21</td></tr> <tr><td style="padding: 2px 10px;">ZONE 22</td></tr> </table> <p>Classification of the Equipment in Groups</p> <table border="1" style="margin: auto; border-collapse: collapse;"> <tr><td style="padding: 2px 10px;">Group IIIA</td></tr> <tr><td style="padding: 2px 10px;">Group IIIB</td></tr> <tr><td style="padding: 2px 10px;">Group IIIC</td></tr> </table> <p>Comparison with art. 500</p> <table border="1" style="margin: auto; border-collapse: collapse;"> <tr><td style="padding: 2px 10px;">Group IIIA</td><td style="padding: 2px 10px;">Class III</td></tr> <tr><td style="padding: 2px 10px;">Group IIIB</td><td style="padding: 2px 10px;">Class II, Group F</td></tr> <tr><td style="padding: 2px 10px;">Group IIIC</td><td style="padding: 2px 10px;">Class II, Group E</td></tr> </table> <p>Marking IEC construction for NEC takes the prefix "AEx"</p> <p style="text-align: center;">Zone 21, AEx tb IIIB T165 °C</p>	ZONE 20	ZONE 21	ZONE 22	Group IIIA	Group IIIB	Group IIIC	Group IIIA	Class III	Group IIIB	Class II, Group F	Group IIIC	Class II, Group E
CLASS I	ZONE 0																																									
CLASS I	ZONE 1																																									
CLASS I	ZONE 2																																									
Group IIA																																										
Group IIB																																										
Group IIC																																										
Group IIA	Group D																																									
Group IIB	Group C																																									
Group IIC	Groups B and A																																									
TEMPERATURE CLASS	MAXIMUM SURFACE T																																									
T1	450 °C																																									
T2	300 °C																																									
T3	200 °C																																									
T4	135 °C																																									
T5	100 °C																																									
T6	85 °C																																									
ZONE 20																																										
ZONE 21																																										
ZONE 22																																										
Group IIIA																																										
Group IIIB																																										
Group IIIC																																										
Group IIIA	Class III																																									
Group IIIB	Class II, Group F																																									
Group IIIC	Class II, Group E																																									

The methods of art. 500 (Classes and Divisions) and the methods of articles 505 and 506 (IEC Zones) are considered equivalent by NEC, the choice depends on the criterion adopted in the initial classification of the areas. Once the classification has been chosen, the requirements for that classification in terms of equipment protection techniques and installation rules (always provided by NEC within the same reference article 500 or 505 and 506) must be strictly followed.

1

ATEX-IECEEx-EAC Ex [⊕ II 2GD]

- Zone 1 (Gb)
- Zone 2 (Gc)
- Zone 21 (Db)
- Zone 22 (Dc)

GAS&DUST

■ ADVANCE-GRP[GD] Series



page 26

■ OPTIMA-EX[GD] Series



page 32

■ ISOLATORS-EX[GD] Series



page 36

■ ROCKER-EX[GD] Series



page 42

■ ZENITH-P Series



page 44

■ ZENITH-S Series



page 60

■ UNION-EX Series



page 80

ADVANCE-GRP[GD] Series

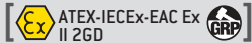

SWITCHED INTERLOCKED SOCKET OUTLETS



The switched interlocked socket outlets with non-sparking switch (Ex db eb) in the ADVANCE-GRP[GD] Series are suitable for installation in environments with classification Ex zone 1/Gb -2/Gc (due to the presence of gases, vapours and mists in group IIC) and/or zone 21/Db - 22/Dc (due to the presence of the combustible dust in group IIIC). The use of a GRP material (Glass-fibre Reinforced Polyester) combined with the substantial thickness of the enclosure walls guarantees excellent mechanical resistance and a long life. This material is highly resistant to contamination and corrosion and is suitable for applications requiring the use of components with a low smoke emission and no halogens (LSOH low smoke zero halogen). The material is charged with "carbon black", which helps reduce the surface resistivity of the material and consequently eliminate the risk of ignition due to the formation of sparks by static electricity. ADVANCE-GRP[GD] interlocked sockets are used exclusively with plugs in the OPTIMA-EX[GD] Series.

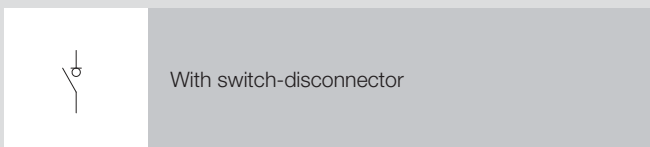

PRODUCTS FOR USE IN A POTENTIALLY EXPLOSIVE ENVIRONMENT

Scame offers products suitable for installation into environments under potential risk of explosion identified as Zone 1/2 and 21/22 and that enter into the field of application for the ATEX Directive (European Directive 94/9/CE).

BEHAVIOUR WITH CHEMICAL AND ATMOSPHERIC AGENTS

Saline solution	Acids		Bases		Solvents				Mineral oil	UV rays
	Concentrated	Diluted	Concentrated	Diluted	Hexane	Benzol	Acetone	Alcohol		
Resistant	Limited Resistance	Resistant	Limited Resistance	Resistant	Resistant	Resistant	Resistant	Resistant	Resistant	Resistant

Resistance values to chemical agents have to be considered indicative. For further information and specific substances, contact the technical service.

REFERENCE STANDARDS

ATEX IECEX	IEC/EN 60079-0 Electrical apparatus for potentially explosive atmospheres. <i>Part 0: General requirements.</i>
ATEX IECEX	IEC/EN 60079-1 Electrical apparatus for potentially explosive atmospheres. <i>Part 1: equipment protection by flameproof enclosures "d".</i>
ATEX IECEX	IEC/EN 60079-7 Electrical apparatus for potentially explosive atmospheres. <i>Part 7: equipment protection by increased safety "e".</i>
ATEX IECEX	IEC/EN 60079-31 Electrical apparatus for potentially explosive atmospheres. <i>Part 31: Protection by enclosures "t".</i>
LVD	IEC/EN 60309-1 Plugs, socket outlets and couplers for industrial purposes. <i>Part 1: general requirements.</i>
LVD	IEC/EN 60309-2 Plugs, socket outlets and couplers for industrial purposes. <i>Part 2: dimensional interchangeability requirements for pin and contact-tube accessories of harmonised configurations.</i>
LVD	IEC/EN 60309-4 Plugs, socket-outlets and couplers for industrial purposes. <i>Part 4: Switched socket-outlets and connectors with or without interlock.</i>

■ TECHNICAL CHARACTERISTICS

Rated current:	16A-32A-63A-125A
Rated voltage:	50÷690V~
Frequency:	50÷60Hz
Insulating voltage:	690V~
Ambient temperature:	16-32A: -50°C ≤Ta ≤+60°C 63A: -35°C ≤Ta ≤+60°C 125A: -35°C ≤Ta ≤+40°C
Protection degree:	IP66
Impact Resistance:	7J
Switched socket outlets with interlock material:	Dissipative Thermosetting (GRP)
Colour:	Black RAL9005

■ Ex CHARACTERISTICS

ATEX Category:	Ex II 2GD
Ex Protection type:	Ex db eb IIC T3,T4, T5, T6 Gb Ex tb IIIC T80°C Db
Surface temperature class DUST:	T80°C
Temperature class GAS:	T3, T4, T5, T6
ATEX Certificate 16A-32A-63A-125A:	INERIS 15ATEX0017X
IECEX Certificate 16A-32A-63A-125A:	IECEX INE 15.0033X
EAC Ex Certificate:	НАИНО ЦСВЭ № TC RU C-IT.AA87.B.00870

■ WIRING OPERATIONS

Rated current (A)	Cable entry	Cable section (max).
16A	1xM25 (*)	12/18
32A	1xM32 (*)	16/25
63A	1xM40 (*)	22/32
125A	1xM50 (*)	28/38,5

(*) You can request the customised configuration of the cable input for the entire series of the ADVANCE-GRP[GD] socket.

■ ELECTRICAL FEATURES SWITCH DISCONNECTORS

Rated Current In		16/32A	63A	CZ0513-180A
Rated insulation voltage Ui	VAC	690	690	690
	415V	-	-	-
	500V	-	-	-
AC22A Mixed resistive and inductive loads, including moderate overloads	690V	32	63	125
	415V	-	-	-
	500V	32	-	-
AC23A Rated operational power (°)	690V	-	63	125
	415V	-	-	-
	500V	25	50	-
AC3 Squirrel-cage motor: starting, switching off motor during running (3 phase / 3 pole)	690V	-	-	125

(°) This values are given for guidance and may vary according to the specifics provided by the motor manufacturer.

ADVANCE-GRP[GD] Series

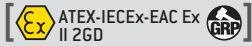

ELECTRICAL PARAMETERS - AUXILIARY CONTACT ATEX/IECEX Certification – Auxiliary Contact

Type	V _{max} - I _{max}	Mode of protection (Nm)	ATEX Certificate	Ambient Temperature
Ex-TECH Solution				
ZBWE - ...	415V – 4A	Ex db eb IIC Gb	INERIS 02 ATEX 9007U	-50°C / +75°C
ZBWE - ...	415V – 4A	Ex db eb IIC Gb	IECEX INE13.0063U	-50°C / +75°C

DRILLING AREA

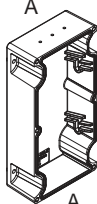
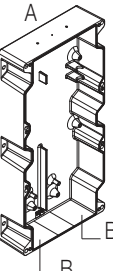
Drilling Area		Socket Size	Cable gland size	Clearance		Max. drill holes
	Dimensions			a	b	
	80x45mm	16/32A A=A	20mm 25mm 32mm	21mm 26mm 33mm	39mm 46mm 56mm	2 2 1
	110x55mm	63A A=A	25mm 32mm 40mm	26mm 33mm 41mm	46mm 56mm 70mm	2 2 1
	196x72mm	125A lato superiore (A)	25mm 32mm 40mm 50mm	26mm 33mm 41mm 51mm	46mm 56mm 70mm 78mm	5 3 2 2
	72x72mm	125A lato inferiore B=B	25mm 32mm 40mm 50mm	26mm 33mm 41mm 51mm	46mm 56mm 70mm 78mm	1 1 1 1

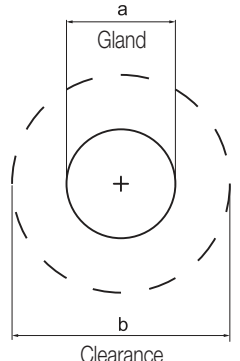

a
Gland
b
Clearance

CROSS SECTIONAL AREAS CONDUCTORS & TORQUE

TERMINALS CONTACTS - TORQUE			
Type	Cross Sectional Areas Conductors		Tightening Torque - (Nm)
	Min.	Max.	
16A	4 mm ²	10 mm ²	0.8
32A	6 mm ²	10 mm ²	0.8
63A	16 mm ²	25 mm ²	2.5
125A	50 mm ²	70 mm ²	3.5

EARTH TERMINALS

EARTH TERMINALS CONTACTS - TORQUE		
Type	Cross Sectional Areas Conductors (mm ²)	Tightening Torque - (Nm)
16/32A	10/16mm ²	1.2
63A	Weidmuller Ex e terminal type WPE35 35mm ²	3.5
125A	50/70mm ²	3.5

ADVANCE-GRP[GD] Series



SWITCHED INTERLOCKED SOCKET OUTLETS - IP66

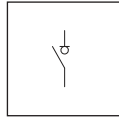

Poles	Hz	Volt	Colour		h.	16A	32A	63A	125A
			16A-32A-63A	125A		1xM25(*) □ 1	1xM32(*) □ 1	1xM40(*) □ 1	1xM50(*) □ 1
2P+E	50/60	100-130		-	4	504.1670	504.3270	-	-
	50/60	200-250		-	6	504.1683	504.3283	-	-
	50/60	380-415		-	9	504.1678	504.3278	-	-
	50/60	480-500		-	7	504.16836	504.32836	-	-
	300÷500	50÷500		-	2	504.16832	504.32832	-	-
3P+E	50/60	100-130			4	504.1672	504.3272	504.6372	504.12572
	50/60	200-250			9	504.1674	504.3274	504.6374	504.12574
	50/60	380-415			6	504.1686	504.3286	504.6386	504.12586
	60	440-460			11	504.16865	504.32865	504.63865	504.125865
	50/60	480-500			7	504.16866	504.32866	504.63866	504.125866
	50/60	600-690			5	504.16867	504.32867	504.63867	504.125867
	50/60	380/440			3	504.16864	504.32864	504.63864	504.125864
	100÷300	50÷690			10	504.16861	504.32861	504.63861	504.125861
	>300÷500	50÷690			2	504.16862	504.32862	504.63862	504.125862
	3P+N+E	50/60	100-130			4	504.1679	504.3279	504.6379
50/60		208-250			9	504.1675	504.3275	504.6375	504.12575
50/60		346-415			6	504.1687	504.3287	504.6387	504.12587
50/60		480-500			7	504.16876	504.32876	504.63876	504.125876
50/60		600-690			5	504.16877	504.32877	504.63877	504.125877
60		440-460			11	504.16875	504.32875	504.63875	504.125875
50/60		380/440			3	504.16874	504.32874	504.63874	504.125874
>300÷500	50÷690			2	504.16872	504.32872	504.63872	504.125872	

□ Package/Bulk Pack.

(*) You can request the customised configuration of the cable input for the entire series of the ADVANCE-GRP[GD] socket. See table pg. 28.

- For frequencies > 100Hz the rated current is declassified to 25%.

- All versions include Ex cable gland and drilled-hole.

ACCESSORIES

EARTH STUD



CONTINUITY EARTH-PLATE TYPE "L"



AUXILIARY CONTACT



- Type "L" earth continuity plate available only with metal cable glands.

CONFIGURATION OPTIONAL ACCESSORIES

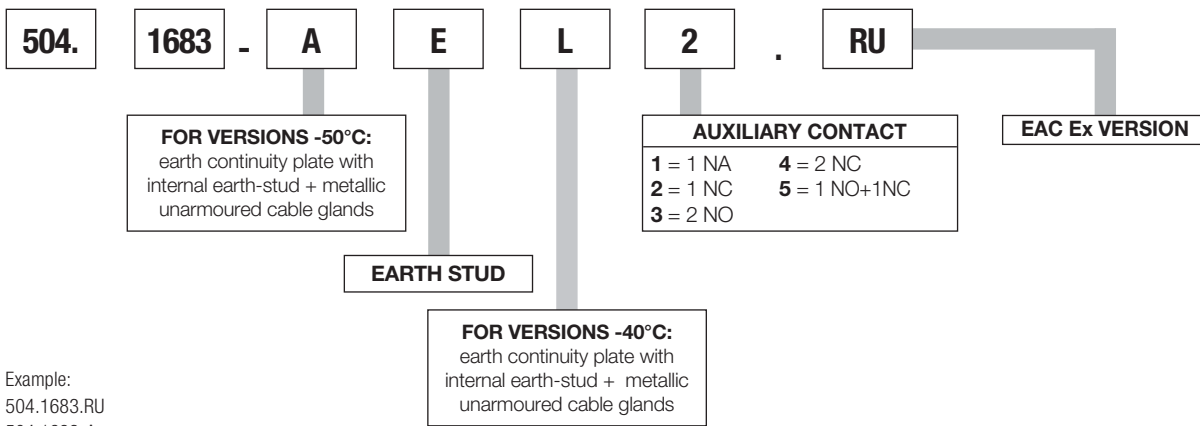

Example:
504.1683.RU
504.1683-A
504.1683-AE.RU

COMBINATIONS OF "POSSIBLE/NON POSSIBLE" PLUG/SOCKET CONNECTIONS

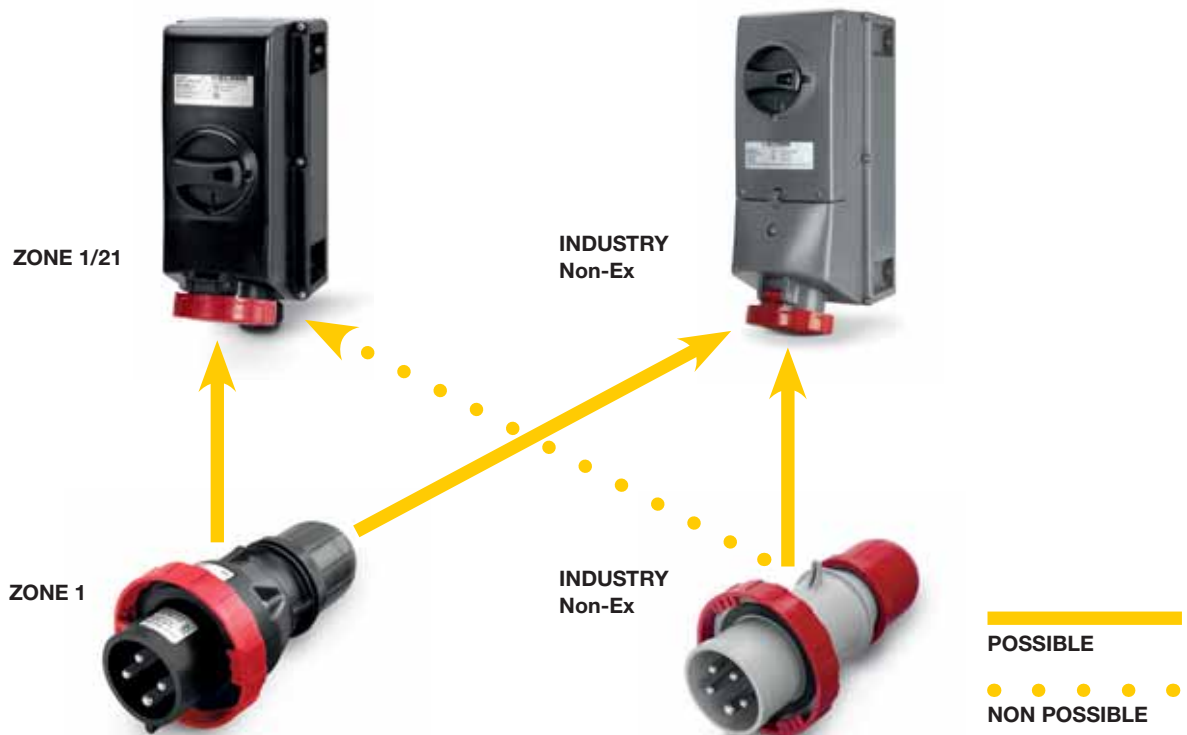

OPTIMA-EX[GD] Series

Ex ATEX-IECEX-EAC Ex II 2GD

PLUGS



Plugs in the OPTIMA-EX[GD] Series (Ex eb) are suitable for use in environments with classification Ex zone 1/Gb -2/Gc (due to the presence of gases, vapours and mists in group IIC) and/or zone 21/Db - 22/Dc (due to the presence of the combustible dust in group IIIC). They are compatible with the interlocked sockets in the ADVANCE-GRP[GD] Series, but can be connected, when in a “safe zone”, to any socket compliant with the industrial standard IEC/EN 60309 having the same polarity.

VERSIONS



Plugs

TECHNICAL CHARACTERISTICS

Rated current:	16A-32A-63A-125A
Rated voltage:	50÷690V~
Frequency:	50÷60Hz
Insulating voltage:	690V~
Ambient temperature:	16-32A: -50°C ≤Ta ≤+60°C 63A: -35°C ≤Ta ≤+60°C 125A: -35°C ≤Ta ≤+40°C
Protection degree:	IP66
Impact Resistance:	7J
Plugs material:	PA6 - Dissipative
Colour:	Black RAL9011

REFERENCE STANDARDS

ATEX IECEX	IEC/EN 60079-0 Electrical apparatus for potentially explosive atmospheres. <i>Part 0: General requirements.</i>
ATEX IECEX	IEC/EN 60079-1 Electrical apparatus for potentially explosive atmospheres. <i>Part 1: equipment protection by flameproof enclosures “d”.</i>
ATEX IECEX	IEC/EN 60079-7 Electrical apparatus for potentially explosive atmospheres. <i>Part 7: equipment protection by increased safety “e”.</i>
ATEX IECEX	IEC/EN 60079-31 Electrical apparatus for potentially explosive atmospheres. <i>Part 31: Protection by enclosures “t”.</i>
LVD	IEC/EN 60309-1 Plugs, socket outlets and couplers for industrial purposes. <i>Part 1: general requirements.</i>
LVD	IEC/EN 60309-2 Plugs, socket outlets and couplers for industrial purposes. <i>Part 2: dimensional interchangeability requirements for pin and contact-tube accessories of harmonised configurations.</i>

Ex CHARACTERISTICS

ATEX Category:	Ex II 2GD
Ex Protection type:	Ex eb IIC T3, T4, T5, T6 Gb Ex tb IIIC T80°C Db
Surface temperature class DUST:	T80°C
Temperature class GAS:	T3, T4, T5, T6
ATEX Certificate 16A-32A-63A-125A:	INERIS 15ATEX0017X
IECEX Certificate 16A-32A-63A-125A:	IECEX INE 15.0033X
EAC Ex Certificate:	НАННО ЦСВЭ № TC RU C-IT.AA87.B.00870

■ BEHAVIOUR WITH CHEMICAL AND ATMOSPHERIC AGENTS

Saline solution	Acids		Bases		Solvents				Mineral oil	UV rays
	Concentrated	Diluted	Concentrated	Diluted	Hexane	Benzol	Acetone	Alcohol		
Resistant	Limited Resistance	Resistant	Limited Resistance	Resistant	Resistant	Resistant	Resistant	Resistant	Resistant	Resistant

Resistance values to chemical agents have to be considered indicative.
For further information and specific substances, contact the technical service.

■ ELECTRICAL FEATURES OPTIMA-EX[GD] SERIES

Rated Current	Maximun Current			Max. Cable Entry Temperature when Ta +60°C
	Ta 40°C	Ta 50°C	Ta 60°C	
16A	16A	16A	16A	80°C (*)
32A	32A	32A	32A	85°C (*)
63A	63A	63A	63A	90°C (*)
125A	100A	112A	125A	-

(*) **WARNING:** the cable entry can be reach high temperature; suitable cable can be used.

APPLICATION EXAMPLES



OPTIMA-EX[GD] Series



TECHNICAL FEATURES

OPTIMA-EX[GD] SERIES	Unit	Value				
		16A	32A	63A	125A	
Rated Current						
Code		219.16...	219.32...	219.63...	219.125...	
Cable section L1 – L2 – L3 – N Ground cable section	(mm ²)	4	6	16	50	
Power Supply Terminals - Tightening-Torque	(Nm)	1	1.5	2	4	
Cable size accepted by Cable-Clamp (eg.H07RN-F) Do not use armoured cable	(mm)	2P+E	14	16	21	30
		3P+E				
		3P+N+E				
Cable Gland/Cable-Clamp Tightening-Torque	(Nm)	2P+E	5,6	10	10	25
		3P+E				
		3P+N+E				
Cable-Gland/Cable-Clamp (Screw) - Tightening-Torque	(Nm)	0.8	0.8	0.8	0.8	
Handle Screws – Tightening-Torque	(Nm)	1	1	1,2	1,5	

PLUGS - IP66

Poles	Hz	Volt	Colour		h.	16A	32A	63A	125A
			16A-32A-63A	125A		cable gland □ 10/40	cable gland □ 10/40	cable gland □ 6/24	cable gland □ 1/8
2P+E	50/60	100-130		-	4	219.1630	219.3230	-	-
	50/60	200-250		-	6	219.1633	219.3233	-	-
	50/60	380-415		-	9	219.1638	219.3238	-	-
	50/60	480-500		-	7	219.16336	219.32336	-	-
	300÷500	50÷500		-	2	219.16332	219.32332	-	-
3P+E	50/60	100-130			4	219.1631	219.3231	219.6331	219.12531
	50/60	200-250			9	219.1634	219.3234	219.6334	219.12534
	50/60	380-415			6	219.1636	219.3236	219.6336	219.12536
	60	440-460			11	219.16365	219.32365	219.63365	219.125365
	50/60	480-500			7	219.16366	219.32366	219.63366	219.125366
	50/60	600-690			5	219.16367	219.32367	219.63367	219.125367
	50/60	380/440			3	219.16364	219.32364	219.63364	219.125364
	100÷300	50÷690			10	219.16361	219.32361	219.63361	219.125361
	>300÷500	50÷690			2	219.16362	219.32362	219.63362	219.125362
	50/60	100-130			4	219.1632	219.3232	219.6332	219.12532
3P+N+E	50/60	208-250			9	219.1635	219.3235	219.6335	219.12535
	50/60	346-415			6	219.1637	219.3237	219.63 37	219.12537
	50/60	480-500			7	219.16376	219.32376	219.63376	219.125376
	50/60	600-690			5	219.16377	219.32377	219.63377	219.125377
	60	440-460			11	219.16375	219.32375	219.63375	219.125375
	50/60	380/440			3	219.16374	219.32374	219.63374	219.125374
	>300÷500	50÷690			2	219.16372	219.32372	219.63372	219.125372

□ Package/Bulk Pack.

- For frequencies > 100Hz the rated current is declassified to 25%.

PLUGS COVER

Description	□
16A-20A	2P+E 570.90163 10/100
	3P+E 570.90164 10/100
	3P+N+E 570.90165 10/100
32A-30A	2P+E and 3P+E 570.90324 10/100
	3P+N+E 570.90325 10/100
63A-60A	2P+E, 3P+E and 3P+N+E 570.9063 10/100
125A-100A	2P+E, 3P+E and 3P+N+E 570.9125 10/100

ISOLATORS-EX[GD] Series



SWITCHES DISCONNECTORS



The load-break switches/disconnectors in the ISOLATORS-EX[GD] Series (Ex db eb) with a switching and isolating function are built in compliance with the standard EN 60947-3.

Able to satisfy all installation needs, they are available in three versions in terms of the material used for the enclosures: thermosetting GRP (Glass-fibre Reinforced Polyester with carbon black), AISI 316L stainless steel and/or aluminium.

They have a category of use up to AC-3 and are available in different versions for general use (handle in black) or for emergency control (high-visibility handle in red/yellow).

VERSIONS



REFERENCE STANDARDS

ATEX IECEX	IEC/EN 60079-0 Electrical apparatus for potentially explosive atmospheres. <i>Part 0: General requirements.</i>
ATEX IECEX	IEC/EN 60079-1 Electrical apparatus for potentially explosive atmospheres. <i>Part 1: equipment protection by flameproof enclosures "d".</i>
ATEX IECEX	IEC/EN 60079-7 Electrical apparatus for potentially explosive atmospheres. <i>Part 7: equipment protection by increased safety "e".</i>
ATEX IECEX	IEC/EN 60079-31 Electrical apparatus for potentially explosive atmospheres. <i>Part 31: Protection by enclosures "t".</i>
LVD	EN 60947-1 Low-voltage switchgear and controlgear. <i>Part 1: general requirements.</i>
LVD	EN 60947-3 Low-voltage switchgear and controlgear. <i>Part 3: Switches, disconnectors, switch-disconnectors and fuse-combination units.</i>

TECHNICAL CHARACTERISTICS

Polarity:	2P - 3/4P
Rated current:	20A-25A-32A-40A-63A
Protection degree:	IP66
Ambient temperature:	-50°C ≤ Ta ≤ +60°C
Material:	Thermosetting (GRP) Stainless steel AISI 316L Aluminium
Colour:	RAL 9006 (aluminium) Satin (stainless steel) RAL 9005 (thermosetting)
Use Category:	AC22A - AC23A - AC3

Ex CHARACTERISTICS

ATEX Category:	Ex II 2GD
Ex Protection type:	Ex d e IIC T4/T5 Gb Ex tb IIIC T80°C Db
Surface temperature class DUST:	T80°C
Temperature class GAS:	T4, T5
ATEX Certificate:	INERIS 14 ATEX 0030X
IECEX Certificate:	IECEX INE 14.0040X
EAC Ex Certificate:	HAHMO ЦCBЭ № TC RU C-IT.AA87.B.00869

■ AMBIENT TEMPERATURE

Ambient temperature range	ISOLATORS-EX[GD] Series					
	591.xxx20xx-xxx 591.xxx25xx-xxx 591.xxx32xx-xxx	591.xxx40xx-xxx 591.Axx63xx-xxx	591.Pxx63xx-xxx		591.Sxx63xx-xxx	
Ambient temperature range	Temperature Class for Gas	Maximum Surface Temperature for Dust	Temperature Class for Gas	Maximum Surface Temperature for Dust	Temperature Class for Gas	Maximum Surface Temperature for Dust
From -20°C to +40°C	T5	T80°C	T5	T80°C	T5	T80°C
From -20°C to +50°C	T5	T80°C	T5	T80°C	T5	T80°C
From -20°C to +55°C	T5	T80°C	T5	T80°C	N/A	T80°C
From -20°C to +60°C	T4	T80°C	N/A	T80°C	N/A	T80°C
From -50°C to +40°C	T5	T80°C	T5	T80°C	T5	T80°C
From -50°C to +50°C	T5	T80°C	T5	T80°C	T5	T80°C
From -50°C to +55°C	T5	T80°C	T5	T80°C	N/A	T80°C
From -50°C to +60°C	T4	T80°C	N/A	T80°C	N/A	T80°C

591.P.../591.S.../591.A... (see table configuration optional accessories pg. 41).

■ BEHAVIOUR WITH CHEMICAL AND ATMOSPHERIC AGENTS - THERMOSETTING

Saline solution	Acids		Bases		Solvents				Mineral oil	UV rays
	Concentrated	Diluted	Concentrated	Diluted	Hexane	Benzol	Acetone	Alcohol		
Resistant	Limited Resistance	Resistant	Limited Resistance	Resistant	Resistant	Resistant	Resistant	Resistant	Resistant	Resistant

■ BEHAVIOUR WITH CHEMICAL AND ATMOSPHERIC AGENTS - STAINLESS STEEL

Saline solution	Acids		Bases		Solvents				Mineral oil	UV rays
	Concentrated	Diluted	Concentrated	Diluted	Hexane	Benzol	Acetone	Alcohol		
Resistant	Limited Resistance	Resistant	Resistant	Resistant	Resistant	Resistant	Resistant	Resistant	Resistant	Resistant

■ BEHAVIOUR WITH CHEMICAL AND ATMOSPHERIC AGENTS - ALUMINIUM

Saline solution	Acids		Bases		Solvents				Mineral oil	UV rays
	Concentrated	Diluted	Concentrated	Diluted	Hexane	Benzol	Acetone	Alcohol		
Resistant	Limited Resistance	Resistant	Resistant	Resistant	Not Resistant	Not Resistant	Not Resistant	Limited Resistance	Resistant	Resistant

Resistance values to chemical agents have to be considered indicative.
For further information and specific substances, contact the technical service.

ISOLATORS-EX[GD] Series



ELECTRICAL FEATURES SWITCH DISCONNECTORS

Rated Current In		20A	25A	32A	40A	63A
Rated insulation voltage Ui	VAC	690	690	690	690	690
AC22A Mixed resistive and inductive loads, including moderate overloads	415V	-	-	-	-	-
	500V	-	-	-	-	-
	690V	20	25	32	40	63
AC23A Rated operational power (°)	415V	-	-	-	-	-
	500V	20	25	32	40	63
	690V	-	-	-	40	63
AC3 Squirrel-cage motor: starting, switching off motor during running (3 phase / 3 pole)	415V	-	-	-	-	-
	500V	20	25	25	40	50
	690V	-	-	-	-	-
Frequency	Hz	50/60	50/60	50/60	50/60	-

(°) This values are given for guidance and may vary according to the specifics provided by the motor manufacturer.

TERMINALS CONTACTS - TORQUE

Terminals Contacts - Torque		
Type COMMAND-EX In	Cross Sectional Areas Conductors mm ²	Tightening Torque - (Nm)
32A	10 finely-stranded	0.8
	16 filo single-wire	0.8
63A	25 finely-stranded	2.5
	35 filo single-wire	2.5
Earth-stud - 32A WPE 10	10 finely-stranded	2.4
	16 filo single-wire	2.4
Earth-stud - 63A WPE 35	35 finely-stranded	5
	35 filo single-wire	5

CABLE ENTRIES

Rated Current	Poles	Cable Entries (mm)	Auxiliary Entries (mm)	Breather/Drain Valve (mm)
20 A	2	2xM25x1,5	M20x1,5	M20x1,5
	3/4			
25 A	2	2xM25x1,5	M20x1,5	M20x1,5
	3/4			
32 A	2	2xM25x1,5	M20x1,5	M20x1,5
	3/4	2xM32x1,5		
40 A	2	2xM32x1,5	M20x1,5	M20x1,5
	3/4	2xM40x1,5		
63 A	2	2xM40x1,5	M20x1,5	M20x1,5
	3/4	2xM50x1,5		

BREATHER/DRAIN VALVE, EARTH-STUD AND AUXILIARY CONTACTS

Optional accessories available on request

APPLICATION EXAMPLES



ISOLATORS-EX[GD] Series

 ATEX-IECEX-EAC Ex II 2GD

THERMOSETTING SWITCHES DISCONNECTORS - IP66



Current	Poles	Cable inlets	Dimensions (mm)	☐	GENERAL USE		EMERGENCY CONTROL	
					■	□	■	■
20A	2	2XM25	160x160x90	1	591.PGE2002		591.PEM2002	
	3/4	2XM25	160x160x90	1	591.PGE2004		591.PEM2004	
25A	2	2XM25	160x160x90	1	591.PGE2502		591.PEM2502	
	3/4	2XM25	160x160x90	1	591.PGE2504		591.PEM2504	
32A	2	2XM25	160x160x90	1	591.PGE3202		591.PEM3202	
	3/4	2XM32	160x160x90	1	591.PGE3204		591.PEM3204	
40A	2	2XM32	250x255x120	1	591.PGE4002		591.PEM4002	
	3/4	2XM40	250x255x120	1	591.PGE4004		591.PEM4004	
63A	2	2XM40	250x255x120	1	591.PGE6302		591.PEM6302	
	3/4	2XM50	250x255x120	1	591.PGE6304		591.PEM6304	

☐ Package/Bulk Pack.

Optional accessories available:

- (E) Earth-stud
- (D) Breather/Drain valve
- (1,2,3,4,5) Auxiliary contacts

(A) For versions <50°C

(L) Type 'L' earth-plate only for metal cable glands (see table configuration optional accessories)

STAINLESS STEEL SWITCHES DISCONNECTORS - IP66

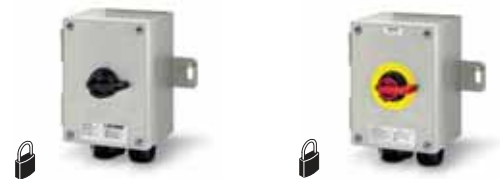

Current	Poles	Cable inlets	Dimensions (mm)	☐	GENERAL USE		EMERGENCY CONTROL	
					■	□	■	■
20A	2	2XM25	141x200x126	1	591.SGE2002		591.SEM2002	
	3/4	2XM25	141x200x126	1	591.SGE2004		591.SEM2004	
25A	2	2XM25	141x200x126	1	591.SGE2502		591.SEM2502	
	3/4	2XM25	141x200x126	1	591.SGE2504		591.SEM2504	
32A	2	2XM25	141x200x126	1	591.SGE3202		591.SEM3202	
	3/4	2XM32	141x200x126	1	591.SGE3204		591.SEM3204	
40A	2	2XM32	270x201x160	1	591.SGE4002		591.SEM4002	
	3/4	2XM40	270x201x160	1	591.SGE4004		591.SEM4004	
63A	2	2XM40	270x201x160	1	591.SGE6302		591.SEM6302	
	3/4	2XM50	270x201x160	1	591.SGE6304		591.SEM6304	

☐ Package/Bulk Pack.
- Earth-stud included

Optional accessories available:

- (D) Breather/Drain valve
- (1,2,3,4,5) Auxiliary contacts

(A) For versions <50°C

(see table configuration optional accessories)

ALUMINIUM SWITCHES DISCONNECTORS - IP66

Current	Poles	Cable inlets	Dimensions (mm)	□	GENERAL USE	
					■	■
20A	2	2XM25	202x232x142	1	591.AGE2002	591.AEM2002
	3/4	2XM25	202x232x142	1	591.AGE2004	591.AEM2004
25A	2	2XM25	202x232x142	1	591.AGE2502	591.AEM2502
	3/4	2XM25	202x232x142	1	591.AGE2504	591.AEM2504
32A	2	2XM25	202x232x142	1	591.AGE3202	591.AEM3202
	3/4	2XM32	202x232x142	1	591.AGE3204	591.AEM3204
40A	2	2XM32	202x232x142	1	591.AGE4002	591.AEM4002
	3/4	2XM40	202x232x142	1	591.AGE4004	591.AEM4004
63A	2	2XM40	202x232x142	1	591.AGE6302	591.AEM6302
	3/4	2XM50	202x232x142	1	591.AGE6304	591.AEM6304

□ Package/Bulk Pack.
- Earth-stud included

Optional accessories available: (see table configuration optional accessories)
(D) Breather/Drain valve
(1,2,3,4,5) Auxiliary contacts
(A) For versions <50°C

Padlockable handle in two positions (ON/OFF).
OFF position = 3 padlocks
ON position = 1 padlock

ACCESSORIES
EARTH-STUD

BREATHER/DRAIN VALVE

CONTINUITY EARTH-PLATE TYPE "L"

AUXILIARY CONTACTS

- Type "L" earth-plate available only with metal cable glands (only for GRP enclosure).

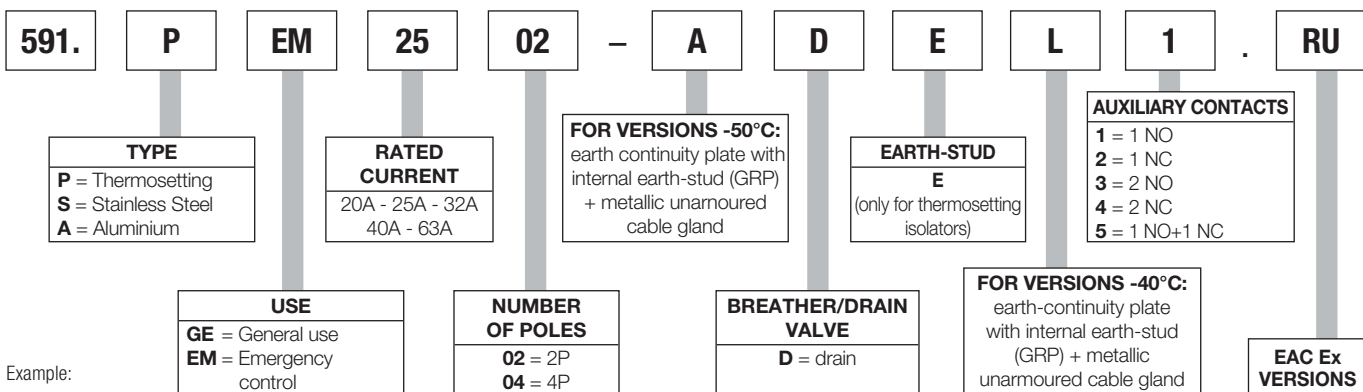
CONFIGURATION OPTIONAL ACCESSORIES

Example:
591.AGE2002.RU
591.SEM2002-ADE
591.PGE2002-L5.RU

ROCKER-EX[GD] Series



Ex ON-OFF SWITCHES/TWO WAY SWITCHES/PUSH BUTTON SWITCHES



Control devices in the ROCKER-EX[GD] Series used to control lighting systems in environments with classification Ex zone 1/Gb -2/Gc (due to the presence of gases, vapours and mists in group IIC) and/or zone 21/Db - 22/Dc (due to the presence of the combustible dust in group IIIC). They are available as an ON-OFF switch, two way switch and 2 poles push-button. Made from a sturdy material charged with glass-fibre, they guarantee functionality in the most adverse weather conditions. They are all available in versions with a different number of entries, in addition to the possibility to select the type of cable gland, in polyamide or nickel-plated brass for a simple or armoured cable.

VERSIONS



ON-OFF switches/two way switch/
push button switches

WIRING DIAGRAMS

ON-OFF switch		two way switch		Push button switch	
2	4	2		2	4
1	3	1	3	1	3

BEHAVIOUR WITH CHEMICAL AND ATMOSPHERIC AGENTS

Saline solution	Acids		Bases		Solvents				Mineral oil	UV rays
	Concentrated	Diluted	Concentrated	Diluted	Hexane	Benzol	Acetone	Alcohol		
Resistant	Limited Resistance	Resistant	Limited Resistance	Resistant	Resistant	Resistant	Resistant	Resistant	Resistant	Resistant

Resistance values to chemical agents have to be considered indicative. For further information and specific substances, contact the technical service.

REFERENCE STANDARDS

ATEX IECEX	IEC/EN 60079-0 Electrical apparatus for potentially explosive atmospheres. <i>Part 0: General requirements.</i>
ATEX IECEX	IEC/EN 60079-1 Electrical apparatus for potentially explosive atmospheres. <i>Part 1: equipment protection by flameproof enclosures "d".</i>
ATEX IECEX	IEC/EN 60079-7 Electrical apparatus for potentially explosive atmospheres. <i>Part 7: equipment protection by increased safety "e".</i>
ATEX IECEX	IEC/EN 60079-31 Electrical apparatus for potentially explosive atmospheres. <i>Part 31: Protection by enclosures "t".</i>
LVD	IEC/EN 60669-1 Switches for household and similar fixed-electrical installations <i>Part 1: General requirements.</i>

TECHNICAL CHARACTERISTICS

Rated current:	16AX (two way switch/ON-OFF switch)
Rated voltage:	250V AC
Protection degree:	IP66
Impact Resistance:	7J
Ambient temperature:	-50°C ≤ Ta ≤ +60°C
Material:	PA6 (glass fiber reinforced)

Ex CHARACTERISTICS

ATEX Category:	Ex II 2GD
Ex Protection type:	Ex db eb IIC T6 Gb Ex db eb IIC T4 Gb Ex tb IIIC T80°C Db
Surface temperature class DUST:	T80°C
Temperature class GAS:	T4, T6
ATEX Certificate:	INERIS 19 ATEX 0014X
IECEX Certificate:	IECEX INE 19.0012X

ON-OFF SWITCHES/TWO WAY SWITCHES/PUSH BUTTON SWITCHES – Ta -35°C

Description	Cable entries	☐	PLASTIC CABLE GLANDS	WITH STOPPING PLUGS
On-Off switches (NO+NO)	1XM20	1	592.R001-01	-
On-Off switches (NO+NO)	2XM20	1	592.R001-02	-
On-Off switches (NO+NO)	1XM20+2XM20	1	592.R001-03	592.R001-03-P
Two way switches (NO+NC)	1XM20	1	592.R002-01	-
Two way switches (NO+NC)	2XM20	1	592.R002-02	-
Two way switches (NO+NC)	1XM20+2XM20	1	592.R002-03	592.R002-03-P
Push button switches (NO+NC)	1XM20	1	592.R003-01	
Push button switches (NO+NC)	2XM20	1	592.R003-02	592.R003-02-P

☐ Package/Bulk Pack.
- Polyamide cable glands.

ON-OFF SWITCHES/TWO WAY SWITCHES/PUSH BUTTON SWITCHES – Ta -50°C

Description	Cable entries	☐	PLASTIC CABLE GLANDS	ARMoured METALLIC CABLE GLANDS
On-Off switches (NO+NO)	1XM20	1	592.R001-01-A	592.R001-01-B
On-Off switches (NO+NO)	2XM20	1	592.R001-02-A	592.R001-02-B
On-Off switches (NO+NO)	1XM20+2XM20	1	592.R001-03-A	592.R001-03-B
Two way switches (NO+NC)	1XM20	1	592.R002-01-A	592.R002-01-B
Two way switches (NO+NC)	2XM20	1	592.R002-02-A	592.R002-02-B
Two way switches (NO+NC)	1XM20+2XM20	1	592.R002-03-A	592.R002-03-B
Push button switches (NO+NC)	1XM20	1	592.R003-01-A	592.R003-01-B
Push button switches (NO+NC)	2XM20	1	592.R003-02-A	592.R003-02-B

☐ Package/Bulk Pack.
- Nickel plated brass cable glands and silicon seal.
Also available in AISI 316L steel (on request).
- Earth plate and earth stud included.

ZENITH-P Series

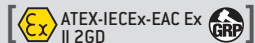

INCREASED SAFETY ENCLOSURES



The ZENITH-P Series includes different sized enclosures in thermosetting GRP (Glass-fibre Reinforced Polyester) with excellent resistance against mechanical strain, contamination, corrosion and is also suitable for LSOH (Low Smoke Zero Halogen) applications.

Moreover, the "carbon black" with which it is charged helps to eliminate the risk of ignition due to static electricity.

The thickness of the walls (minimum 4 mm) allows the creation of entry holes, even threaded, through the direct use of machine tools.

VERSIONS

	Empty enclosure
	Junction box
	Control and command station

TECHNICAL CHARACTERISTICS

Degree of protection:	IP66
Service temperature, empty enclosures:	-60°C ≤ Ta ≤ +100°C
Ambient temperature, junction boxes, control stations:	-60°C ≤ Ta ≤ +75°C
Impact resistance:	7 J
Material:	<ul style="list-style-type: none"> • Glass Reinforced Polyester (SMC) • Loaded with carbon black
Surface resistance:	Antistatic properties: < 10⁹ Ω
Finish:	Natural Black RAL 9005

REFERENCE STANDARDS

ATEX IECEX	IEC/EN 60079-0 Electrical apparatus for potentially explosive atmospheres. <i>Part 0: General requirements.</i>
ATEX IECEX	IEC/EN 60079-7 Electrical apparatus for potentially explosive atmospheres. <i>Part 7: equipment protection by increased safety "e".</i>
ATEX IECEX	IEC/EN 60079-11 Electrical apparatus for potentially explosive atmospheres. <i>Part 11: intrinsic safety "i".</i>
ATEX IECEX	IEC/EN 60079-18 Electrical apparatus for potentially explosive atmospheres. <i>Part 18: Equipment protection by encapsulation "m".</i>
ATEX IECEX	IEC/EN 60079-31 Electrical apparatus for potentially explosive atmospheres. <i>Part 31: Protection by enclosures "t".</i>

Ex CHARACTERISTICS

ATEX Category:	Ex II 2GD
Ex Protection type:	
Empty enclosures	Ex eb IIC Gb Ex tb IIIC Db
Junction boxes	Ex eb IIC T6, T5, T4 Gb or Ex e IIC T6, T5, T4 Gb Ex ia IIC T6, T5, T4 Ga Ex eb ia IIC T6, T5, T4 Gb or Ex e ia IIC T6, T5, T4 Gb
Control stations	Ex tb IIIC T80°C, T95°C or T130°C Db Ex db eb IIC T6,T5,T4 Gb or Ex d e IIC T6,T5,T4 Gb Ex db eb mb IIC T6,T5,T4 Gb or Ex d e mb IIC T6,T5,T4 Gb Ex eb mb IIC T6,T5,T4 Gb or Ex e mb IIC T6,T5,T4 Gb Ex tb IIIC T80°C, T95°C, T130°C Db
Surface temperature class DUST:	T40°C, T50°C, T60°C, T75°C
Temperature class GAS:	T4, T5, T6
Certificates:	
- Empty enclosure	IMQ 19 ATEX 033 U IECEX IMQ 19.0004 U
- Junction boxes	IMQ 19 ATEX 034 X IECEX IMQ 19.0005 X
- Control station	IMQ 19 ATEX 034 X IECEX IMQ 19.0005 X

BEHAVIOUR WITH CHEMICAL AND ATMOSPHERIC AGENTS

Saline solution	Acids		Bases		Solvents				Mineral oil	UV rays
	Concentrated	Diluted	Concentrated	Diluted	Hexane	Benzol	Acetone	Alcohol		
Resistant	Limited Resistance	Resistant	Limited Resistance	Resistant	Resistant	Resistant	Resistant	Resistant	Resistant	Resistant

Resistance values to chemical agents have to be considered indicative.
For further information and specific substances, contact the technical service.

LID FIXING SCREWS



Corrosion-resistant stainless steel (complete with retaining washer) for flat blade screwdriver and PH screwdriver. The assembly holes are outside the sealed area.

TERMINAL MOUNTING



Terminals will be mounted on rails or on internal plates. DIN rail (TS 15, TS 35): 1 row. Certified terminals with nominal section from 1.5mm² up to 240mm².

JUNCTION BOX EXAMPLE

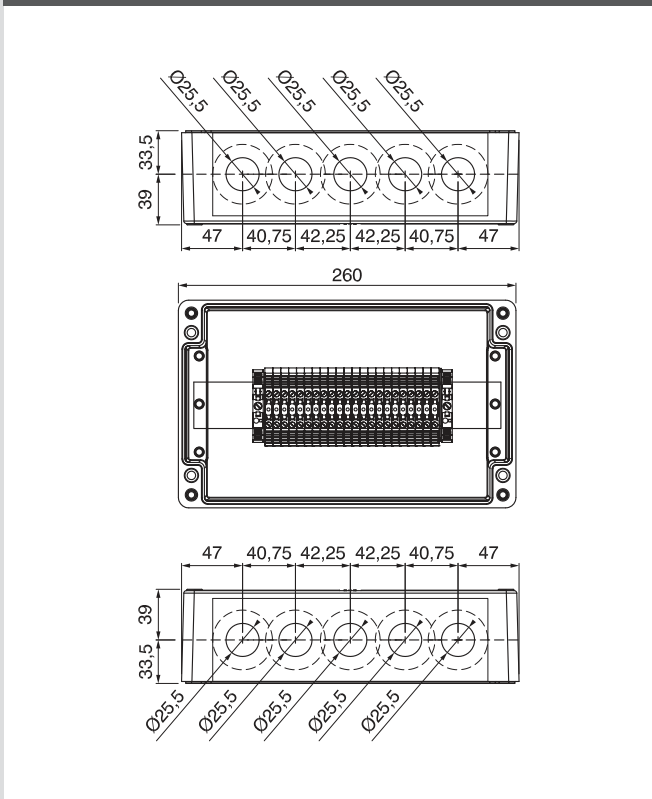

CONTROL STATION EXAMPLE

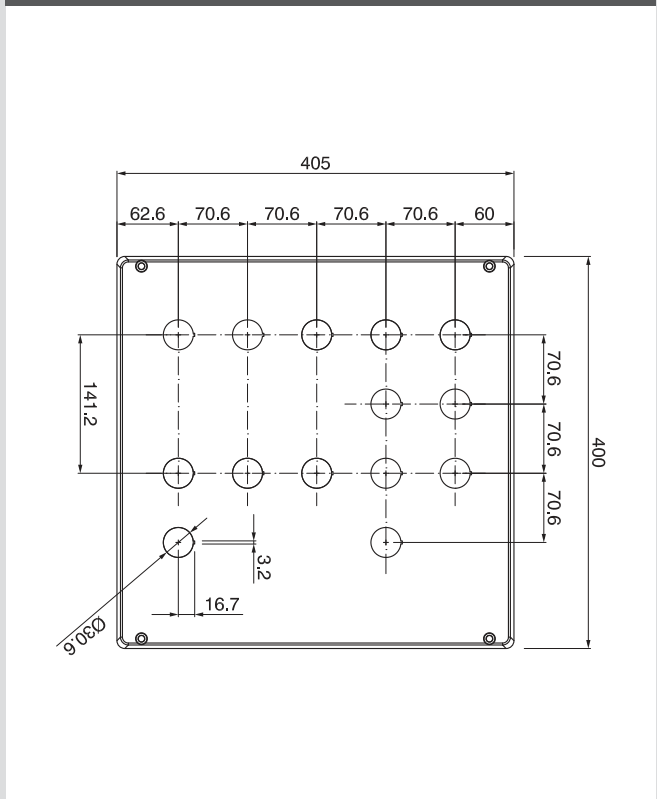

ZENITH-P Series

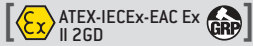

■ EMPTY ENCLOSURE



The empty enclosures in the ZENITH-P Series are approved with component certification ("U"). This partial certificate can be used as a basis for the certification of a complete system or to guarantee IP66 and/or Zone 2/22 protection in applications in the self-certification scheme. They are suitable for installation in environments with classification Ex zone 1/Gb -2/Gc (due to the presence of gases, vapours and mists in group IIC) and/or zone 21/Db - 22/Dc (due to the presence of the combustible dust in group IIIC).

■ JUNCTION BOX



The ZENITH-P Series can be customised as a junction box, equipping it with various sized terminals with separate ATEX-IECEX certification. Special versions can be developed in accordance with client specifications. Other accessories can be included, such as an earth continuity plate, earth-stud, earth-bar and plastic or metal cable gland, or drain/breather valves. They are available in preconfigured versions.

■ ACCESSORIES

- Plate bottom in zinc-plated steel
- Fixing bracket in stainless steel AISI 316L
- Earth continuity plate (internal) in zinc-plated steel
- Earth stud (pin, nuts and washer) in brass (available in stainless steel AISI 316L)
- Drain and breather valve
- Cable glands / plugs
- Actuators/components
- Analog instruments
- Threaded earth-bar



Empty enclosure

Junction box

Pre-drilled enclosure

CONTROL AND COMMAND STATION



The ZENITH-P Series can be customised as a control station. The control stations can be assembled to house a broad range of actuators and components with separate ATEX-IECEX certification, including buttons, indicators, selectors, analogue instruments, etc. It is also possible to customise units including MCB, MCBO, RCD, transformers, disconnectors, fuses, timer or thermal relays, all with "Ex db eb" certification. They are available in preconfigured versions.

ADDITIONAL FEATURES FOR CONTROL STATIONS

- Push buttons/lighting push buttons
- Selector switches
- LED lamps
- Potentiometers
- Analog instruments (ammeters/voltmeters)
- Power resistors
- Diodes
- Voltage regulators (zener)
- Protection zener
- Electronic relays
- Resistive modules
- Fuses (up to 12,5A)
- Drain valves / breathers
- Fused terminals (up to 6,3A)
- MCB
- RCD
- RCBo
- Power contactors
- Motor starters + thermal relays
- Motor protection with disconnecter
- Thermal relays
- Temporized relays
- Miniaturized relays
- Transformers
- Power disconnectors up to 180A in AC3

CUSTOMIZED SOLUTIONS



Scame has ATEX and IECEx certification.

An efficient in-house analysis and quoting service is able to support clients during the decision-making process, generating offers and feasibility studies in a short time.

Thanks to production flexibility based on the principles of Lean Production and the use of highly qualified personnel and leading edge machinery, the company is able to develop junction boxes and control stations in customised configurations based on client specifications, without necessarily the need for large production batches.



Enclosure + ECP



Enclosure + internal plate



Junction and terminal box without cable glands

ZENITH-P Series

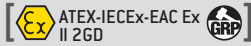

ATEX-IECEX CERTIFIED TERMINALS

The terminals with separate certification must be selected from the following list of approved manufacturers. Additional manufacturers are available on requested, subject to approval by our internal laboratory. Terminal blocks (internal plate mounted) and mini terminals (DIN rail TS15) are suited for use with small enclosures.

Standard rail terminals (DIN rail TS35) are suited for use with large enclosures.

When the enclosure is supplied as Ex ia (intrinsic safety application), a suitable set of blue terminals is supplied. The terminals can be the screw or spring-cage type.

The cross-section ranges from 1.5 mm² to 240 mm².

TYPE Ω TS 35

Dimensions (mm)	Description		
35x7,5x1	Flat DIN rail	40m	865.220
	Slotted DIN rail (18x6.3 - 25)	40m	865.221

Package/Bulk Pack.

TYPE Ω TS 15

Dimensions (mm)	Description		
15x5,5x1	Flat DIN rail	100m	865.240
	Slotted DIN rail (12,2x4,2 - 20)	100m	865.241

Package/Bulk Pack.

CABLE ENTRIES

Enclosure size (H x W x D)	Top/Bottom sides A/C								Left/Right sides B/D								Rear side F		
	M12	M16	M20	M25	M32	M40	M50	M63	M12	M16	M20	M25	M32	M40	M50	M63	M20	M25	M32
75x80x75	4	2	1	1	-	-	-	-	2	2	-	-	-	-	-	-	2	1	-
75x110x75	6	6	3	2	1	-	-	-	2	2	-	-	-	-	-	-	2	2	1
75x160x75	10	10	5	3	2	-	-	-	2	2	-	-	-	-	-	-	3	3	3
75x190x75	14	12	6	4	3	-	-	-	2	2	-	-	-	-	-	-	3	3	3
75x230x75	16	12	6	4	2	-	-	-	2	2	-	-	-	-	-	-	3	3	3
120x122x90	6	5	2	1	1	-	-	-	5	5	4	1	1	-	-	-	3	3	3
120x220x90	14	14	9	4	3	-	-	-	5	4	2	1	1	-	-	-	3	3	3
160x160x90	12	8	6	3	2	1	-	-	6	6	4	2	1	-	-	-	3	3	3
160x260x90	26	16	12	6	4	3	-	-	6	6	4	2	1	-	-	-	3	3	3
160x360x90	38	22	18	9	6	4	-	-	6	6	4	2	1	-	-	-	3	3	3
160x560x90	58	36	28	14	8	6	-	-	6	6	4	2	1	-	-	-	3	3	3
250x255x120	24	18	10	8	4	3	2	2	21	15	8	6	3	2	2	1	3	3	3
250x400x120	42	33	18	16	6	5	4	3	21	15	8	6	3	2	2	1	3	3	3
405x400x165	70	44	27	21	12	10	4	3	65	40	24	21	10	10	4	3	3	3	3

On the short side is not possible to use cable glands ≥ M40 with earth continuity plate.

ENCLOSURE DRILLING ENVELOPE

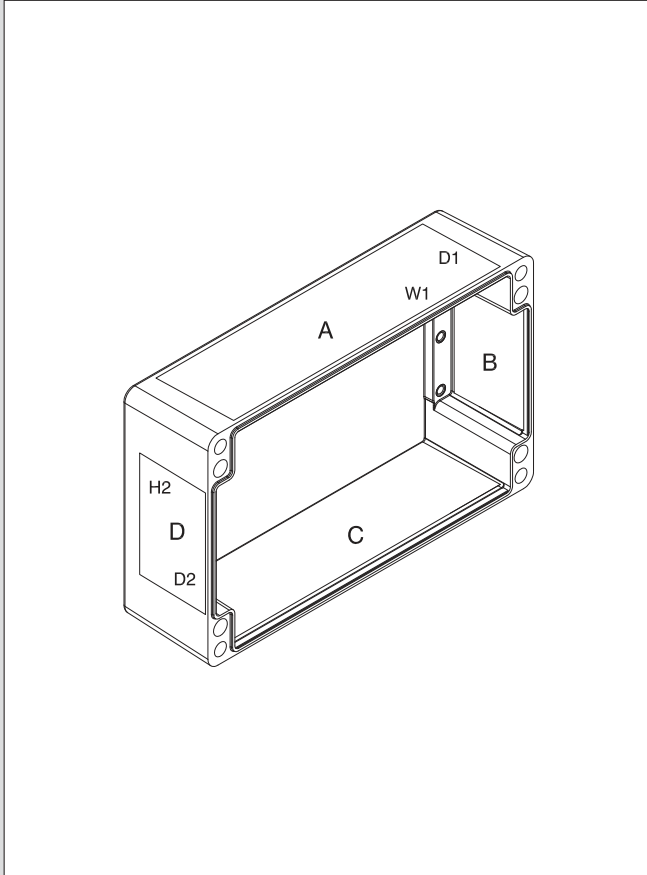

Enclosure size (H x W x D)	Top/Bottom sides A/C W1xD1	Left/Right sides B/D H2xD2
75x80x55	48x34	28x28
75x80x75	48x54	27x48
75x110x55	80x34	28x28
75x110x75	80x54	27x48
75x160x55	130x34	28x28
75x160x75	130x54	27x48
75x190x55	160x34	28x28
75x190x75	160x54	27x48
75x230x55	90x34(x2)	28x28
75x230x75	90x54(x2)	27x48
120x122x90	75x58	60x52
120x220x90	180x58	60x52
160x160x90	110x65	84x56
160x260x90	210x65	84x56
160x360x90	310x65	84x56
160x560x90	240x65(x2)	84x56
250x255x120	200x88	168x81
250x400x120	345x88	168x81
405x400x165	345x133	323x126

DRILLING CLEARANCES

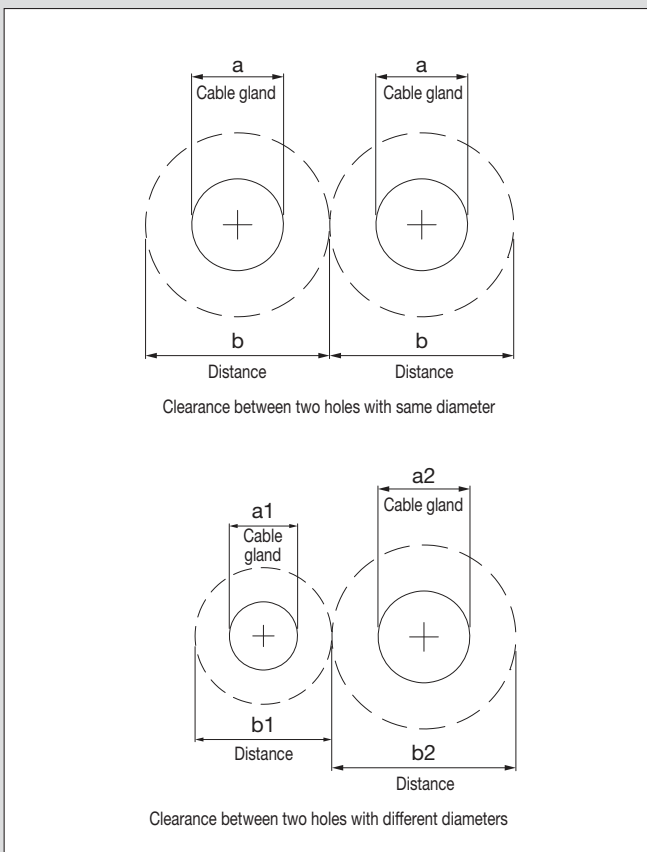

Cable gland size a (mm)	Minimum clearances between holes b (mm)	Minimum clearances from the edge (*) (mm)
12	25	23
16	32	27
20	39	33
25	46	43
32	58	54
40	68	68
50	81	81
63	96	96

(*) Minimum distance from the enclosure edge or the limit drilling area.

ZENITH-P Series



LID DRILLING ENVELOPE

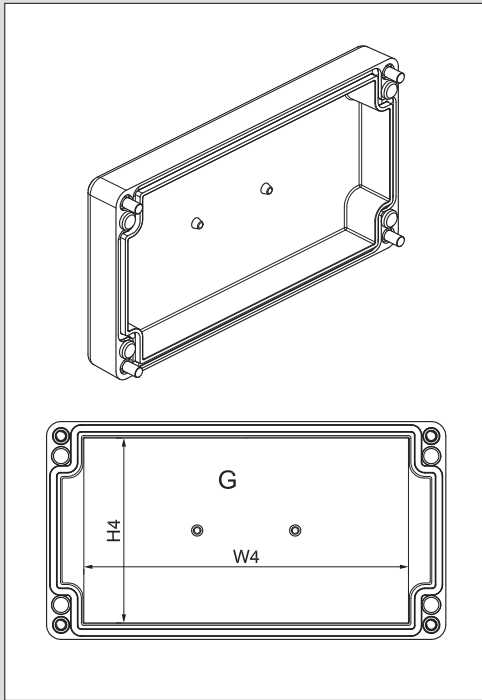

Enclosure size (H x W x D)	Maximum drilling area G (H4 x W4)	Max no. of holes			
		Ø30,5 mm	Ø22,5 mm	Ø32,5 mm	Ø30,8mm (with keyway)
75x80x75	55 x 45	/	1	/	1
75x110x75	55 x 75	/	1	/	1
75x160x75	55 x 125	/	2	/	1
75x190x75	55 x 155	/	3	/	2
75x230x75	55 x 195	/	3	/	2
120x122x90	102 x 80	1	2	1	2
120x220x90	102 x 179	2	6	2	4
160x160x90	140 x 110	2	4	2	4
160x260x90	140 x 210	6	6	6	6
160x360x90	140 x 310	8	10	8	10
160x560x90	140 x 510	13	18	13	18
250x255x120	230 x 205	9	12	9	12
250x400x120	230 x 350	15	24	15	18
405x400x165	385 x 350	25	40	25	30

CLEARANCE AND CREEPAGE

Manufacturer Actuator/Control Components	Maximum Mounting Ø a - (mm)	Minimum distance between two holes b - (mm)	Minimum distance between two holes c - (mm)
SCHNEIDER-ELECTRIC	Ø22,5	35	35
EX-TECH	Ø22,5	35	35
CZ	Ø30,6 (with keyway)	20	40

SQUARE LID DRILLING AREA

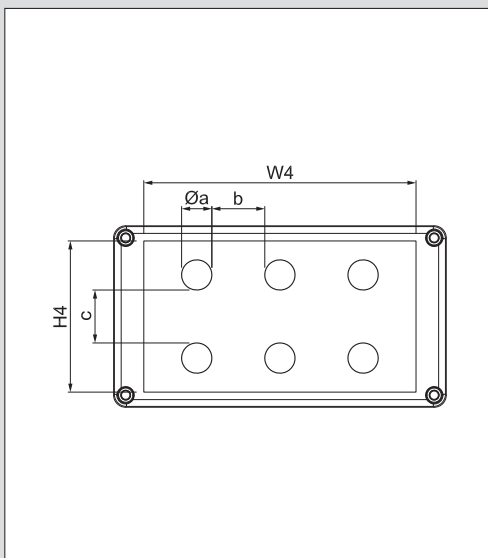

Enclosure size (H x W x D)	Maximum drilling area G (H4 x W4)	Maximum SQUARE holes		
		Maximum number	Maximum Size	Minimum distance between two holes b - (mm)
120x122x90	102 x 80	1	57x53mm	60
120x220x90	102 x 179	2	57x53mm	60
160x160x90	140 x 110	1	118x95mm	60
160x260x90	140 x 210	1	118x95mm	60
160x360x90	140 x 310	2	118x95mm	60
160x560x90	140 x 510	3	118x95mm	70
250x255x120	230 x 205	1	118x95mm	60
250x400x120	230 x 350	2	118x95mm	75
405x400x165	385 x 350	4	118x95mm	75
		2	255x85mm	100

■ DRAIN AND BREATHER VALVE HOLES DRILLING ENVELOPE

Enclosure size (H x W x D)	Top/Bottom sides A/C W1xD1	Left/Right sides B/D H2xD2
75x80x55	48x34	28x28
75x80x75	48x54	27x48
75x110x55	80x34	28x28
75x110x75	80x54	27x48
75x160x55	130x34	28x28
75x160x75	130x54	27x48
75x190x55	160x34	28x28
75x190x75	160x54	27x48
75x230x55	90x34 (x2)	28x28
75x230x75	90x54 (x2)	27x48
120x122x90	75x58	60x52
120x220x90	180x58	60x52
160x160x90	110x65	84x56
160x260x90	210x65	84x56
160x360x90	310x65	84x56
160x560x90	240x65 (x2)	84x56
250x255x120	200x88	168x81
250x400x120	345x88	168x81
405x400x165	345x133	323x126

■ HOLE DIAMETER

Hole diameter (mm) M20 x/y position 16	Hole diameter (mm) M25 x/y position 20	Hole diameter (mm) M12 x/y position 15
Ø 20.5/21	Ø 25.5/26	Ø 12.2/12.4

Values refer to all codes in Table 1.

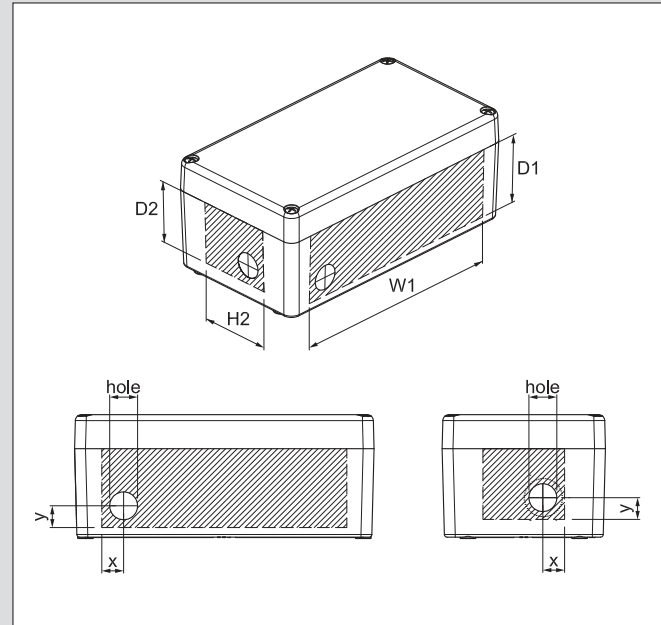

The drain and breather valve must always be assembled on the bottom side of the enclosure.

ZENITH-P Series



ENCLOSURES



		H	W	D	ENCLOSURE
CONTROL STATIONS	JUNCTION BOXES	75	80	55	644.0100
			110	55	644.0110
			160	55	644.0120
			190	55	644.0130
			230	55	644.0140
			80	75	644.0200
			110	75	644.0210
			160	75	644.0220
	190	75	644.0230		
	230	75	644.0240		
	120	122	90	644.0345	
		220	90	644.0350	
		160	160	90	644.0360
			260	90	644.0370
			360	90	644.0380
	250	560	90	644.0390	
255		120	644.0465		
405	400	120	644.0485		
	400	165	644.0595		

ACCESSORIES



EARTH CONTINUITY PLATE	INTERNAL MOUNTING PLATE	TYPE L EARTH-PLATE
644.A0100	644.B00	644.0100L
644.A0110	644.B10	644.0110L
644.A0120	644.B20	644.0120L
644.A0130	644.B30	644.0130L
644.A0140	644.B40	644.0140L
644.A0200	644.B00	644.0200L
644.A0210	644.B10	644.0210L
644.A0220	644.B20	644.0220L
644.A0230	644.B30	644.0230L
644.A0240	644.B40	644.0240L
644.A0345	644.B45	644.0345L
644.A0350	644.B50	644.0350L
644.A0360	644.B60	644.0360L
644.A0370	644.B70	644.0370L
644.A0380	644.B80	644.0380L
644.A0390	644.B90	644.0390L
644.A0465	644.B65	644.0465L
644.A0485	644.B85	644.0485L
644.A0595	644.B95	644.0595L

DIMENSIONAL REFERENCES

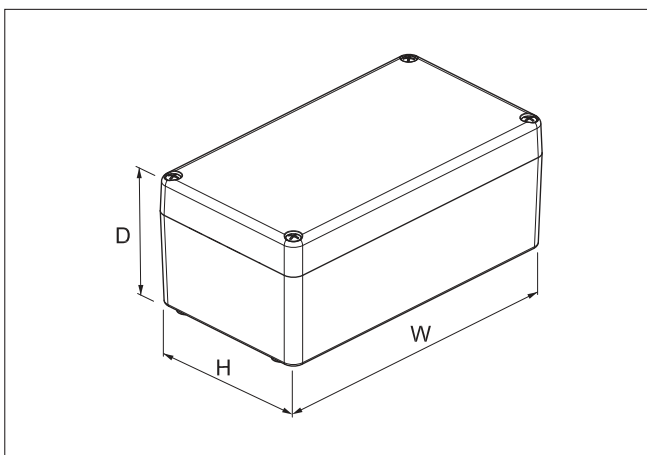



H	W	D	EXTERNAL MOUNTING BRACKETS	EXTERNAL MOUNTING VERTICAL FEET	EARTH STUD	PADLOCK
75	80	55	644.C075	644.D075	644.E650 (BRASS)	644.G001
	110	55				
	160	55				
	190	55				
	230	55				
120	80	75	644.C120	644.D120	644.E651 (STEEL)	644.G002
	110	75				
	160	75				
	190	75				
160	220	90	644.C160	644.D160	644.E651 (STEEL)	644.G003
	160	90				
	260	90				
250	360	90	644.C160	644.D160	644.E651 (STEEL)	644.G004
	560	90				
405	255	120	644.C160	644.D250	644.E651 (STEEL)	644.G005
	400	120				
405	400	165	644.C160	644.D405	644.E651 (STEEL)	644.G006

ZENITH-P Series • PRECONFIGURED VERSIONS



4xWDU + 1WPE 4,0mm² - 4xM20

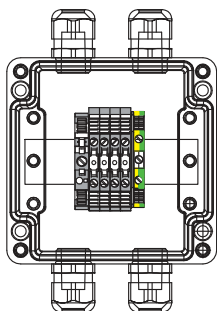

code: 644.0345-J01

TECHNICAL CHARACTERISTICS

Ex Protection type:	Ex eb IIC T6 Gb Ex tb IIIC T80°C Db - IP66
Operating temperature range:	-30°C ≤Ta ≤+40°C
Maximum current per terminal:	24A
Category of use:	-
Rated voltage:	690V
Dimensions:	122x120x90mm

8xWDU 4,0mm² (bridged 2/2) + 2WPE - 4xM20

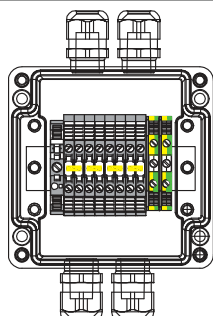

code: 644.0345-J02

TECHNICAL CHARACTERISTICS

Ex Protection type:	Ex eb IIC T6 Gb Ex tb IIIC T80°C Db - IP66
Operating temperature range:	-30°C ≤Ta ≤+40°C
Maximum current per terminal:	20A
Category of use:	-
Rated voltage:	690V
Dimensions:	122x120x90mm

4xWDU + 1WPE 6,0mm² - 3xM20

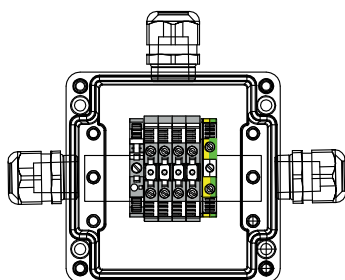

code: 644.0345-J03

TECHNICAL CHARACTERISTICS

Ex Protection type:	Ex eb IIC T6 Gb Ex tb IIIC T80°C Db - IP66
Operating temperature range:	-30°C ≤Ta ≤+40°C
Maximum current per terminal:	30A
Category of use:	-
Rated voltage:	550V
Dimensions:	122x120x90mm

8xWDU 6,0mm² (bridged 2/2) + 2WPE - 3xM20

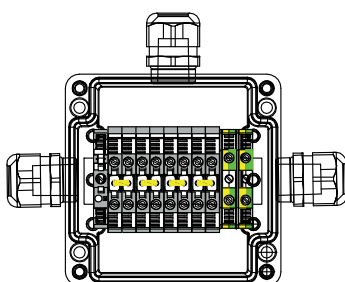

code: 644.0345-J04

TECHNICAL CHARACTERISTICS

Ex Protection type:	Ex eb IIC T6 Gb Ex tb IIIC T80°C Db - IP66
Operating temperature range:	-30°C ≤Ta ≤+40°C
Maximum current per terminal:	25A
Category of use:	-
Rated voltage:	550V
Dimensions:	122x120x90mm

■ 10x2,5mm² CAGE TERMINAL - 4xM20 (plugged)

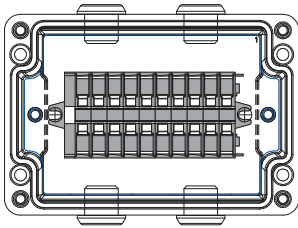

code: 644.0210-J10

TECHNICAL CHARACTERISTICS

Ex Protection type:	Ex eb IIC T6 Gb Ex tb IIIC T80°C Db - IP66
Operating temperature range:	-30°C ≤ Ta ≤ +40°C
Maximum current per terminal:	12A
Category of use:	-
Rated voltage:	690V
Dimensions:	75x110x75mm

■ 14x2,5mm² CAGE TERMINAL - 6xM20 (plugged)

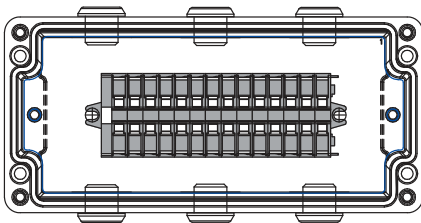

code: 644.0220-J14

TECHNICAL CHARACTERISTICS

Ex Protection type:	Ex eb IIC T6 Gb Ex tb IIIC T80°C Db - IP66
Operating temperature range:	-30°C ≤ Ta ≤ +40°C
Maximum current per terminal:	12A
Category of use:	-
Rated voltage:	690V
Dimensions:	75x160x75mm

■ 20x2,5mm² CAGE TERMINAL - 8xM20 (plugged)

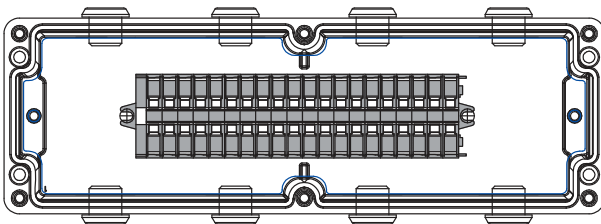

code: 644.0240-J20

TECHNICAL CHARACTERISTICS

Ex Protection type:	Ex eb IIC T6 Gb Ex tb IIIC T80°C Db - IP66
Operating temperature range:	-30°C ≤ Ta ≤ +40°C
Maximum current per terminal:	11A
Category of use:	-
Rated voltage:	690V
Dimensions:	75x230x75mm

■ EMERGENCY (pull to release) 2NC - 1xM20

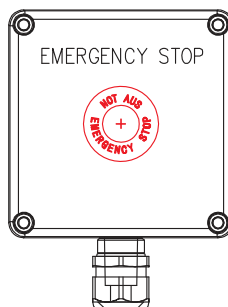
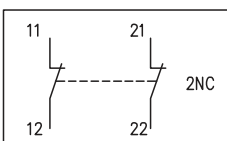

code: 644.0345-ES

TECHNICAL CHARACTERISTICS

Ex Protection type:	Ex db eb IIC T6 Gb Ex tb IIIC T80°C Db - IP66
Operating temperature range:	-30°C ≤ Ta ≤ +40°C
Maximum current per terminal:	16A
Category of use:	AC12-AC3-AC23
Rated voltage:	250AC
Dimensions:	122x120x90mm

ZENITH-P Series • PRECONFIGURED VERSIONS



EMERGENCY (pull to release) 2NC + SAFETY CATCH + PADLOCK - 1xM20

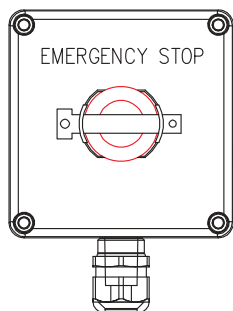
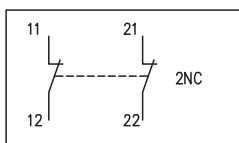

code: 644.0345-ESL

TECHNICAL CHARACTERISTICS

Ex Protection type:	Ex db eb IIC T6 Gb Ex tb IIIC T80°C Db - IP66
Operating temperature range:	-30°C ≤Ta ≤+40°C
Maximum current per terminal:	16A
Category of use:	AC12-AC3-AC23
Rated voltage:	250AC
Dimensions:	122x120x90mm

PUSH BUTTON 1NO+1NC - 1xM20

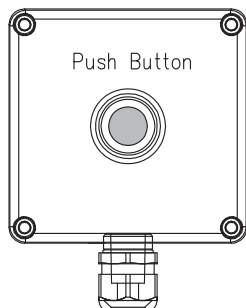
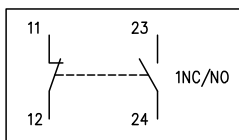

- code: 644.0345-PBG - push button color **GREEN**
- code: 644.0345-PBR - push button color **RED**
- code: 644.0345-PBW - push button color **WHITE**
- code: 644.0345-PBY - push button color **YELLOW**
- code: 644.0345-PBK - push button color **BLACK**

TECHNICAL CHARACTERISTICS

Ex Protection type:	Ex db eb IIC T6 Gb Ex tb IIIC T80°C Db - IP66
Operating temperature range:	-30°C ≤Ta ≤+40°C
Maximum current per terminal:	16A
Category of use:	AC12-AC3-AC23
Rated voltage:	250AC
Dimensions:	122x120x90mm

LED LIGHT 12-250VAC/VDC - 1xM20

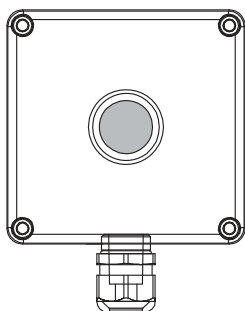

- code: 644.0345-LDG - led color **GREEN**
- code: 644.0345-LDR - led color **RED**
- code: 644.0345-LDW - led color **WHITE**
- code: 644.0345-LDY - led color **YELLOW**
- code: 644.0345-LDB - led color **BLUE**

TECHNICAL CHARACTERISTICS

Ex Protection type:	Ex db eb IIC T6 Gb Ex tb IIIC T80°C Db - IP66
Operating temperature range:	-30°C ≤Ta ≤+40°C
Maximum current per terminal:	10mA
Category of use:	-
Rated voltage:	12-250AC/VDC
Dimensions:	122x120x90mm

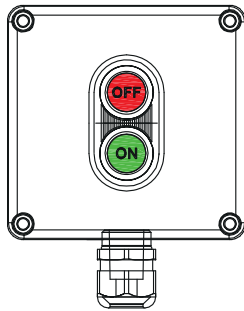
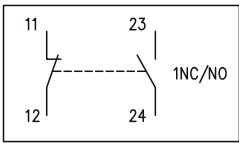
ON/OFF DOUBLE PUSH BUTTON + 1NO + 1NC - 1xM20

code: 644.0345-OF
TECHNICAL CHARACTERISTICS

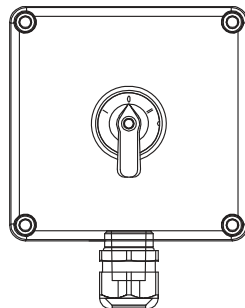
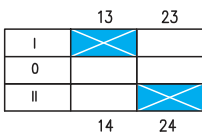
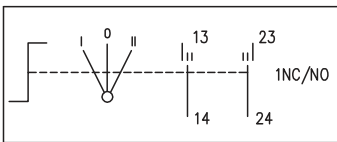
Ex Protection type:	Ex db eb IIC T6 Gb Ex tb IIIC T80°C Db - IP66
Operating temperature range:	-30°C ≤ Ta ≤ +40°C
Maximum current per terminal:	16A
Category of use:	AC12-AC3-AC23
Rated voltage:	250AC
Dimensions:	122x120x90mm

SELECTOR SWITCH "1-0-2" + 1NO + 1NC REVERTING 2NO IN "0" - 1xM20

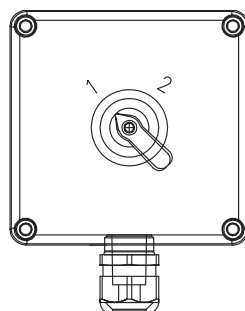
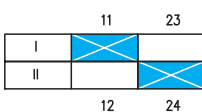
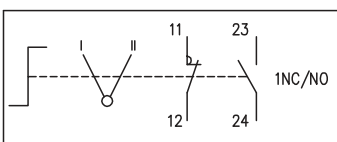
code: 644.0345-SE3
TECHNICAL CHARACTERISTICS

Ex Protection type:	Ex db eb IIC T6 Gb Ex tb IIIC T80°C Db - IP66
Operating temperature range:	-30°C ≤ Ta ≤ +40°C
Maximum current per terminal:	16A
Category of use:	AC12-AC3-AC23
Rated voltage:	250AC
Dimensions:	122x120x90mm

SELECTOR SWITCH "I-II" 1NO + 1NC REVERTING - 1xM20

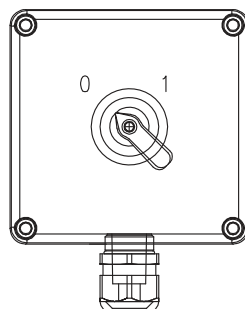
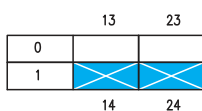
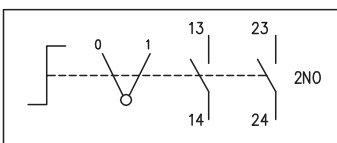
code: 644.0345-SE2
TECHNICAL CHARACTERISTICS

Ex Protection type:	Ex db eb IIC T6 Gb Ex tb IIIC T80°C Db - IP66
Operating temperature range:	-30°C ≤ Ta ≤ +40°C
Maximum current per terminal:	16A
Category of use:	AC12-AC3-AC23
Rated voltage:	250AC
Dimensions:	122x120x90mm

SELECTOR SWITCH "0/1" 2NO - 1xM20

code: 644.0345-SE1
TECHNICAL CHARACTERISTICS

Ex Protection type:	Ex db eb IIC T6 Gb Ex tb IIIC T80°C Db - IP66
Operating temperature range:	-30°C ≤ Ta ≤ +40°C
Maximum current per terminal:	16A
Category of use:	AC12-AC3-AC23
Rated voltage:	250AC
Dimensions:	122x120x90mm

ZENITH-P Series • PRECONFIGURED VERSIONS

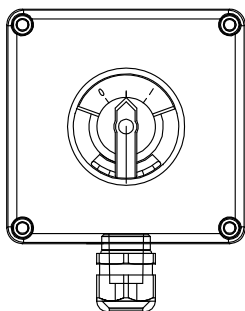
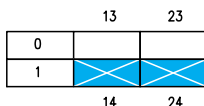
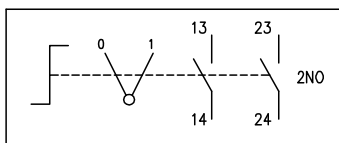

■ SELECTOR SWITCH "0/1" 2NO LOCKABLE HANDLE - 1xM20



code: 644.0345-SE1L

TECHNICAL CHARACTERISTICS

Ex Protection type:	Ex db eb IIC T6 Gb Ex tb IIIC T80°C Db - IP66
Operating temperature range:	-30°C ≤ Ta ≤ +40°C
Maximum current per terminal:	16A
Category of use:	AC12-AC3-AC23
Rated voltage:	250AC
Dimensions:	122x120x90mm

■ ON/OFF DOUBLE PUSH BUTTON 1NO + 1NC + EMERGENCY PUSH BUTTON 2NC - 1xM25

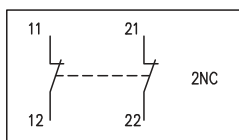

EMERGENCY

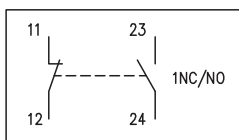

START/STOP



code: 644.0350-OFE

TECHNICAL CHARACTERISTICS

Ex Protection type:	Ex db eb IIC T6 Gb Ex tb IIIC T80°C Db - IP66
Operating temperature range:	-30°C ≤ Ta ≤ +40°C
Maximum current per terminal:	16A
Category of use:	AC12-AC3-AC23
Rated voltage:	250AC
Dimensions:	220x120x90mm

■ 1xSTART PUSH BUTTON 2NO + 1xSTOP PUSH BUTTON 2NC - 1xM25

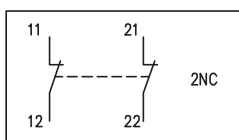

STOP

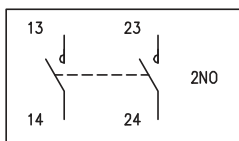

START

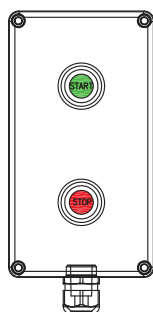

code: 644.0350-SS

TECHNICAL CHARACTERISTICS

Ex Protection type:	Ex db eb IIC T6 Gb Ex tb IIIC T80°C Db - IP66
Operating temperature range:	-30°C ≤ Ta ≤ +40°C
Maximum current per terminal:	16A
Category of use:	AC12-AC3-AC23
Rated voltage:	250AC
Dimensions:	220x120x90mm

■ 1xSTART LIGHTING PUSH BUTTON 1NO + 1xSTOP PUSH BUTTON 2NC - 1xM25

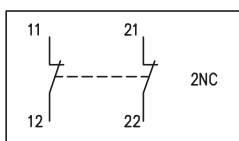

STOP

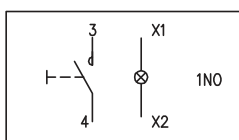

START

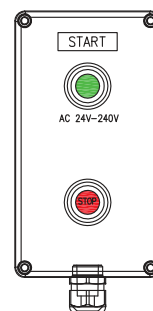

code: 644.0350-SGS

TECHNICAL CHARACTERISTICS

Ex Protection type:	Ex db eb IIC T6 Gb Ex tb IIIC T80°C Db - IP66
Operating temperature range:	-30°C ≤ Ta ≤ +40°C
Maximum current per terminal:	16A
Category of use:	AC15-AC3-AC23
Rated voltage:	250AC
Dimensions:	220x120x90mm

1xSTART PUSH BUTTON 2NO + 1xEMERGENCY PUSH BUTTON 2NC - 1xM25

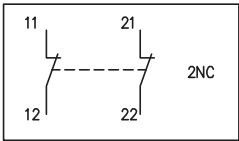

EMERGENCY

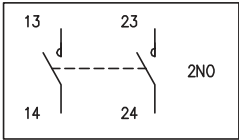

START



code: 644.0350-SE

TECHNICAL CHARACTERISTICS

Ex Protection type:	Ex db eb IIC T6 Gb Ex tb IIIC T80°C Db - IP66
Operating temperature range:	-30°C ≤Ta ≤+40°C
Maximum current per terminal:	16A
Category of use:	AC12-AC3-AC23
Rated voltage:	250AC
Dimensions:	220x120x90mm

APPLICATION EXAMPLES



ZENITH-S Series

Ex ATEX-IECEX-EAC Ex II 2GD

INCREASED SAFETY ENCLOSURES



The ZENITH-S Series includes enclosures in AISI 304L or AISI 316L steel. The enclosures can be supplied with screw-fixed lid, with hinges and/or flanges on the four sides.

They are suitable for installation in environments with classification Ex zone 1/Gb -2/Gc (due to the presence of gases, vapours and mists in group IIC) and/or zone 21/Db - 22/Dc (due to the presence of the combustible dust in group IIIC).

VERSIONS



Empty enclosure

Junction box

Control and command station

TECHNICAL CHARACTERISTICS

Degree of protection:	IP66
Service temperature, empty enclosures:	-50°C ≤ Ta ≤ +100°C
Ambient temperature, junction boxes, control stations:	-50°C ≤ Ta ≤ +75°C
Impact resistance:	7 J
Material:	<ul style="list-style-type: none"> • AISI 316L • AISI 304L
Finish:	Glossy satin

REFERENCE STANDARDS

ATEX IECEX	<p>IEC/EN 60079-0 Electrical apparatus for potentially explosive atmospheres. <i>Part 0: General requirements.</i></p>
ATEX IECEX	<p>IEC/EN 60079-1 Electrical apparatus for potentially explosive atmospheres. <i>Part 1: equipment protection by flameproof enclosures "d".</i></p>
ATEX IECEX	<p>IEC/EN 60079-7 Electrical apparatus for potentially explosive atmospheres. <i>Part 7: equipment protection by increased safety "e".</i></p>
ATEX IECEX	<p>IEC/EN 60079-11 Electrical apparatus for potentially explosive atmospheres. <i>Part 11: intrinsic safety "i".</i></p>
ATEX IECEX	<p>IEC/EN 60079-18 Electrical apparatus for potentially explosive atmospheres. <i>Part 18: Equipment protection by encapsulation "m".</i></p>
ATEX IECEX	<p>IEC/EN 60079-31 Electrical apparatus for potentially explosive atmospheres. <i>Part 31: Protection by enclosures "t".</i></p>

Ex CHARACTERISTICS

ATEX Category:	Ex II 1G, 2GD
Ex Protection type:	Ex eb IIC Gb
Empty enclosures	Ex tb IIIC Db
Junction boxes:	Ex eb IIC T6, T5, T4 Gb or Ex e IIC T6, T5, T4 Gb Ex eb ia IIC T6, T5, T4 Gb or Ex e ia IIC T6, T5, T4 Gb Ex ia IIC T6, T5, T4 Ga Ex tb IIIC T80°C, T95°C or T130°C Db
Control stations:	Ex db eb IIC T6,T5,T4 Gb or Ex d e IIC T6,T5,T4 Gb Ex db eb mb IIC T6,T5,T4 Gb or Ex d e mb IIC T6,T5,T4 Gb Ex eb mb IIC T6,T5,T4 Gb or Ex e mb IIC T6,T5,T4 Gb Ex tb IIIC T80°C, T95°C, T130°C Db
Surface temperature class DUST:	T80°C, T95°C, T130°C
Temperature class GAS:	T4, T5, T6
Certificates:	
- Empty enclosure	IMQ 19 ATEX 033 U IECEX IMQ 19.0004 U
- Junction boxes	IMQ 19 ATEX 034 X IECEX IMQ 19.0005 X
- Control station	IMQ 19 ATEX 034 X IECEX IMQ 19.0005 X

BEHAVIOUR WITH CHEMICAL AND ATMOSPHERIC AGENTS

Saline solution	Acids		Bases		Solvents				Mineral oil	UV rays
	Concentrated	Diluted	Concentrated	Diluted	Hexane	Benzol	Acetone	Alcohol		
Resistant	Limited Resistance	Resistant	Limited Resistance	Resistant	Resistant	Resistant	Resistant	Resistant	Resistant	Resistant

Resistance values to chemical agents have to be considered indicative.
For further information and specific substances, contact the technical service.

TERMINAL MOUNTING



Terminals will be mounted on rails or on internal plates. DIN rail (TS 15, TS 35): 1 row. Certified terminals with nominal section from 1.5 mm² up to 240mm².

APPLICATION EXAMPLES



ZENITH-S Series

 ATEX-IECEX-EAC Ex
II 2GD

■ EMPTY ENCLOSURE



The empty enclosures in the ZENITH-S Series are approved with component certification ("U"). This partial certificate can be used as a basis for the certification of a complete system or to guarantee IP66 and/or Zone 2/22 protection in applications in the self-certification scheme. They are suitable for installation in environments with classification Ex zone 1/Gb -2/Gc (due to the presence of gases, vapours and mists in group IIC) and/or zone 21/Db - 22/Dc (due to the presence of the combustible dust in group IIIC).

■ JUNCTION BOX



The ZENITH-S Series can be customised as a junction box, equipping it with various sized terminals with separate ATEX-IECEX certification. Special versions can be developed in accordance with client specifications. Other accessories can be included, such as plastic or metal cable glands for simple and armoured cables, or drain/breather valves. They are suitable for installation in environments with classification Ex zone 1/Gb -2/Gc (due to the presence of gases, vapours and mists in group IIC) and/or zone 21/Db - 22/Dc (due to the presence of the combustible dust in group IIIC).

■ ACCESSORIES

- Plate bottom in zinc-plated steel/ AISI 316L / AISI 304L
- Fixing bracket in stainless steel AISI 316L / AISI 304L
- Drain and breather valve (M12 or M25)
- Ex e plastic / nickel-plated brass / AISI 316L / AISI 304L cable glands and plugs
- Actuators/components
- Analog instruments

■ CONTROL AND COMMAND STATION



The ZENITH-S Series can be customised as a control station. The control stations can be assembled to house a broad range of actuators and components with separate ATEX-IECEX certification, including buttons, indicators, selectors, analogue instruments, etc... It is also possible to customise units including MCB, MCBO, RCD, transformers, disconnectors, fuses, timer or thermal relays, all with "Ex db eb" certification. They are suitable for installation in environments with classification Ex zone 1/Gb -2/Gc (due to the presence of gases, vapours and mists in group IIC) and/or zone 21/Db - 22/Dc (due to the presence of the combustible dust in group IIIC).

■ ADDITIONAL FEATURES FOR CONTROL STATIONS

- Push buttons/lighting push buttons
- Selector switches
- LED lamps
- Potentiometers
- Analog instruments (ammeters/voltmeters)
- Power resistors
- Diodes
- Voltage regulators (zener)
- Protection zener
- Electronic relays
- Resistive modules
- Fuses (up to 12,5A)
- Drain valves / breathers

■ CUSTOMIZED SOLUTIONS

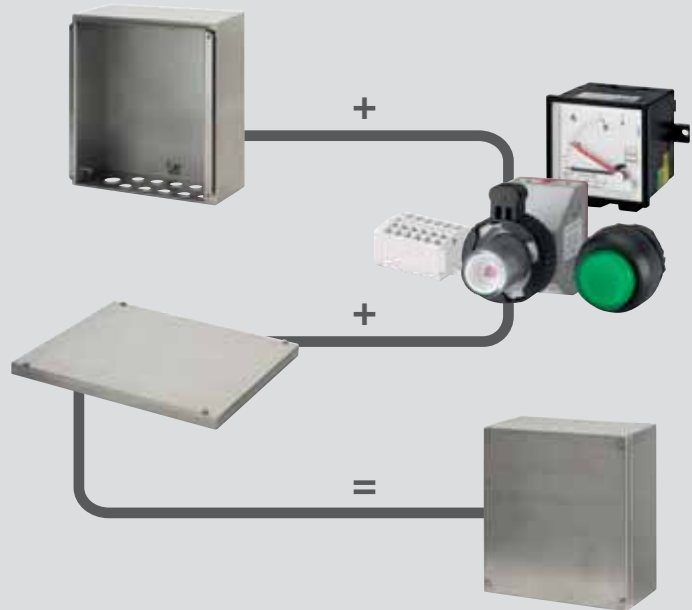

Scame has ATEX and IECEx certification.

An efficient in-house analysis and quoting service is able to support clients during the decision-making process, generating offers and feasibility studies in a short time.

Thanks to production flexibility based on the principles of Lean Production and the use of highly qualified personnel and leading edge machinery, the company is able to develop junction boxes and control stations in customised configurations based on client specifications, without necessarily the need for large production batches.

- Fused terminals (up to 6,3A)
- MCB
- RCD
- RCBo
- Power contactors
- Motor starters + thermal relays
- Motor protection with disconnecter
- Thermal relays
- Temporized relays
- Miniaturized relays
- Transformers
- Power disconnectors up to 180A in AC3

ZENITH-S Series

Ex ATEX-IECEX-EAC Ex II 2GD

645.B - BOX DRILLING AREA

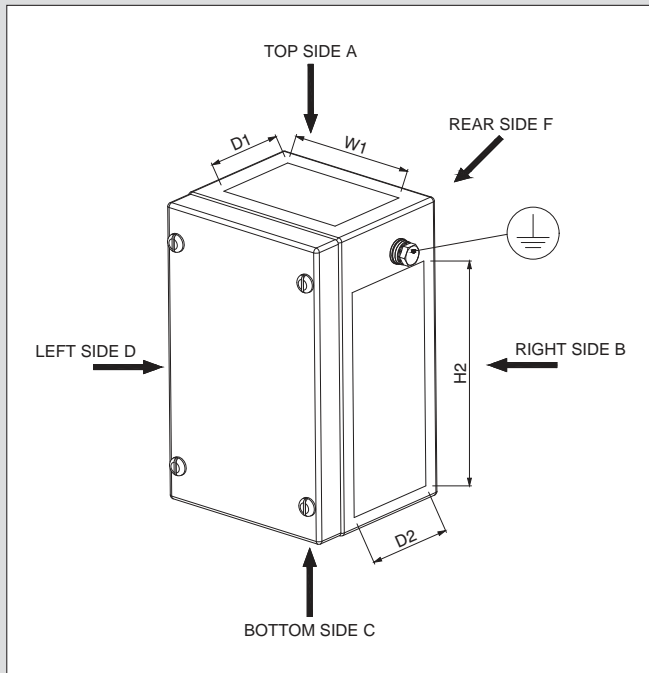

Enclosure size (W x H x D)	Top/Bottom sides A/C W1 x D1	Left/Right sides B/D H2 x D2
90x90x75	80x50	80x50
100x100x90	90x65	90x65
100x160x90	90x65	150x65
100x220x90	90x65	210x65
150x160x120	140x95	150x95
150x220x120	140x95	210x95
150x280x120	140x95	270x95
200x220x120	190x95	210x95
200x280x120	190x95	270x95
250x280x120	240x95	270x95
250x340x150	240x125	330x125
300x340x150	290x125	330x125
300x400x150	290x125	390x125
400x400x150	390x125	390x125

645.B - LID DRILLING AREA

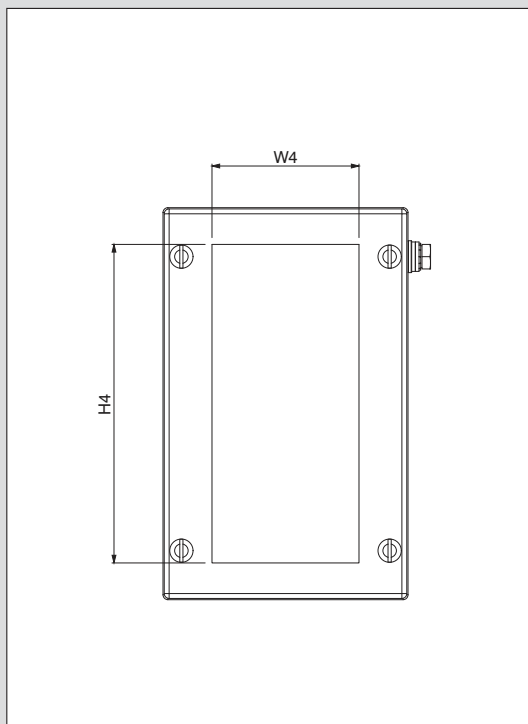

Enclosure size (W x H x D)	Maximum drilling area G (H4 x W4)	Max no. of holes			
		Ø 30,5mm	Ø 22,5mm	Ø 32,5mm	Ø30,8mm Ø30,6mm (with keyway)
90x90x75	50x60	\	\	\	\
100x100x90	60x70	1	1	1	1
100x160x90	60x130	1	1	1	1
100x220x90	60x190	2	2	2	2
150x160x120	110x130	2	2	2	2
150x220x120	110x190	3	3	3	3
150x280x120	110x250	4	4	4	4
200x220x120	160x190	5	5	5	5
200x280x120	160x250	7	7	7	7
250x280x120	210x250	9	9	9	9
250x340x150	210x310	12	12	12	12
300x340x150	260x310	15	15	15	15
300x400x150	260x370	15	15	15	15
400x400x150	360x370	25	25	25	25

CLEARANCE AND CREEPAGE

Manufacturer Actuator/Control Components	Maximum Mounting Ø a - (mm)	Minimum distance between two holes b - (mm)	Minimum distance between two holes c - (mm)
SCHNEIDER-ELECTRIC	Ø22,5	35	35
EX-TECH	Ø22,5	35	35
CZ	Ø30,6 (with keyway)	20	40

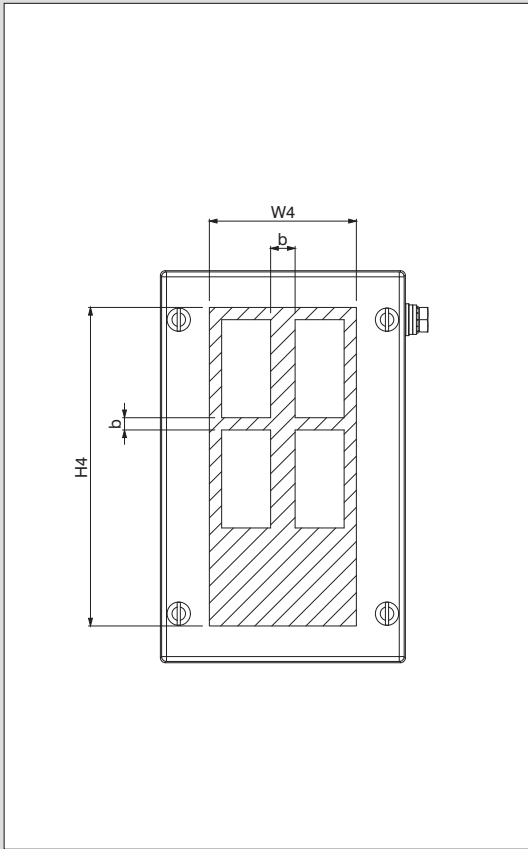
645.B - LID SQUARE WINDOWS DRILLING

Enclosure size (W x H x D)	Maximum drilling area G (H4 x W4)	Maximum square holes		
		Maximum number	Maximum Size	Minimum distance between two holes b - (mm)
90x90x75	50x60	-	-	-
100x100x90	60x70	1	57x53mm	60
100x160x90	60x130	1	57x53mm	60
100x220x90	60x190	2	57x53mm	60
150x160x120	110x130	1	57x53mm	60
150x220x120	110x190	2	57x53mm	60
150x280x120	110x250	3	57x53mm	60
200x220x120	160x190	1	118x95mm	60
200x280x120	160x250	2	118x95mm	60
250x280x120	210x250	2	118x95mm	60
250x340x150	210x310	2	118x95mm	60
300x340x150	260x310	2	118x95mm	60
		1	255x85mm	100
300x400x150	260x370	2	118x95mm	75
		1	255x85mm	100
400x400x150	360x370	2	118x95mm	75
		1	255x85mm	100

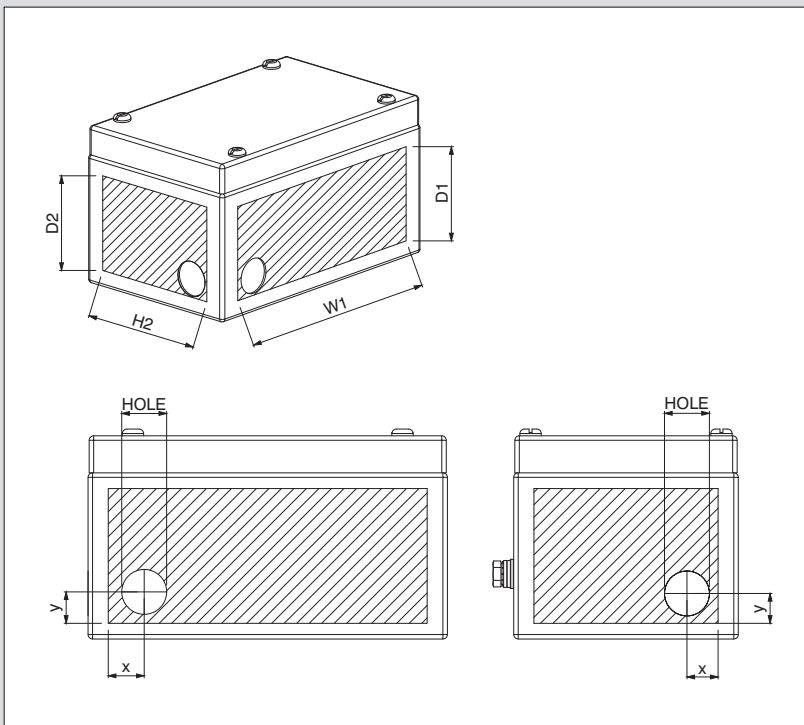
645.B - DRILLING DRAIN/BREATHER POSITION

Hole	Hole diameter			
	M12	M16	M20	M25
	\emptyset 12,2/ 12,4mm	\emptyset 16,4/ 16,8mm	\emptyset 20,5/ 21mm	\emptyset 25,5/ 26mm
X	15mm	16mm	16mm	20mm
Y	15mm	16mm	16mm	20mm

ZENITH-S Series

[Ex] ATEX-IECEX-EAC Ex II 2GD

645.B - CABLE ENTRIES

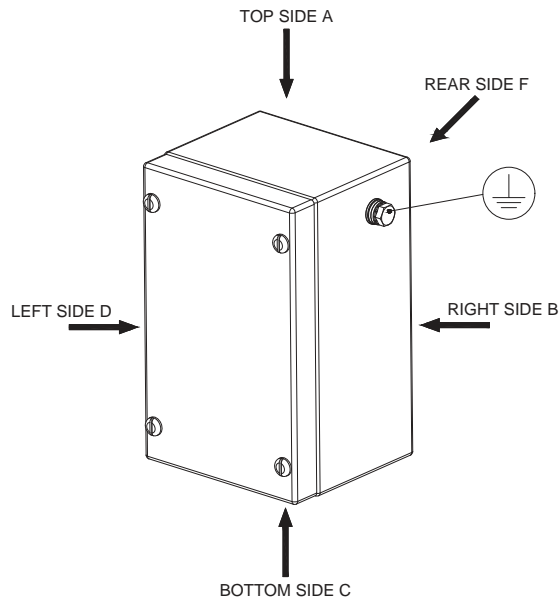

Enclosure size (W x H x D)	Top/Bottom sides A/C								Left/Right sides B/D								Rear side F				
	M12	M16	M20	M25	M32	M40	M50	M63	M12	M16	M20	M25	M32	M40	M50	M63	M16	M20	M25	M32	M40
90x90x75	6	3	2	2	1	-	-	-	6	3	2	2	1	-	-	-	2	2	2	-	-
100x100x90	8	4	3	2	1	1	-	-	8	4	3	2	1	1	-	-	2	2	2	-	-
100x160x90	8	4	3	2	1	1	-	-	12	9	5	3	2	2	-	-	2	2	2	-	-
100x220x90	8	4	3	2	1	1	-	-	16	10	7	5	4	3	-	-	3	3	3	3	-
150x160x120	20	12	8	6	3	2	1	1	20	12	8	6	3	2	1	1	3	3	3	3	1
150x220x120	20	12	8	6	3	2	1	1	30	18	11	8	5	3	2	2	3	3	3	3	1
150x280x120	20	12	8	6	3	2	1	1	40	24	14	10	6	4	3	2	3	3	3	3	1
200x220x120	26	15	10	8	5	3	2	2	30	18	11	8	5	3	2	2	3	3	3	3	1
200x280x120	26	15	10	8	5	3	2	2	40	24	14	10	6	4	3	2	3	3	3	3	1
250x280x120	34	21	12	10	5	3	3	2	40	24	14	10	6	4	3	2	3	3	3	3	1
250x340x150	45	28	18	14	8	5	3	2	60	40	24	20	10	7	4	3	3	3	3	3	1
300x340x150	50	34	21	17	10	6	4	3	60	40	24	20	10	7	4	3	3	3	3	3	1
300x400x150	50	34	21	17	10	6	4	3	60	46	27	21	12	8	5	4	3	3	3	3	1
400x400x150	60	46	27	21	12	8	5	4	60	46	27	21	12	8	5	4	3	3	3	3	1

LID SCREW ENCLOSURES - AISI 316L

W	H	D	AISI 316L ENCLOSURES
90	90	75	645.B6S01
	100	90	645.B6S02
100	160	90	645.B6S03
	220	90	645.B6S04
150	160	120	645.B6S05
	220	120	645.B6S06
	280	120	645.B6S07
200	220	120	645.B6S08
	280	120	645.B6S09
250	280	120	645.B6S10
	340	150	645.B6S11
300	340	150	645.B6S12
	400	150	645.B6S13
400	400	150	645.B6S14

ACCESSORIES

GALVANIZED EARTH PLATE	AISI 316L EARTH PLATE	MOUNTING BRACKETS
-	-	
-	-	
645.B8P03	645.B6P03	
645.B8P04	645.B6P04	
645.B8P05	645.B6P05	
645.B8P06	645.B6P06	
645.B8P07	645.B6P07	
645.B8P08	645.B6P08	
645.B8P09	645.B6P09	
645.B8P10	645.B6P10	
645.B8P11	645.B6P11	
645.B8P12	645.B6P12	
645.B8P13	645.B6P13	
645.B8P14	645.B6P14	

645.B6F

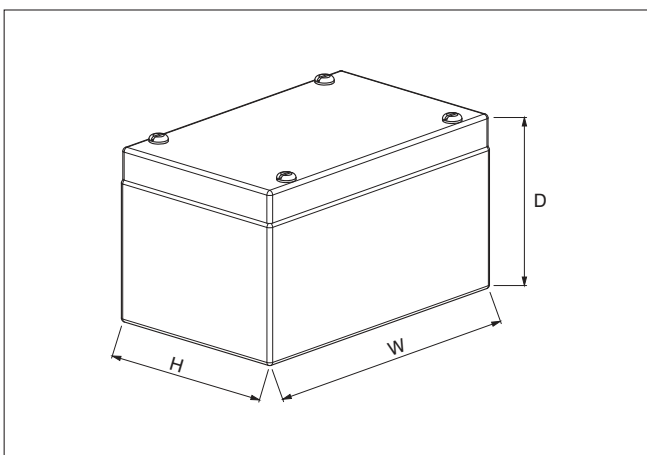
DIMENSIONAL REFERENCES

ZENITH-S Series

 ATEX-IECEX-EAC Ex II 2GD

LID SCREW ENCLOSURES - AISI 304L



W	H	D	AISI 304L ENCLOSURES
90	90	75	645.B4S01
	100	90	645.B4S02
100	160	90	645.B4S03
	220	90	645.B4S04
150	160	120	645.B4S05
	220	120	645.B4S06
	280	120	645.B4S07
200	220	120	645.B4S08
	280	120	645.B4S09
250	280	120	645.B4S10
	340	150	645.B4S11
300	340	150	645.B4S12
	400	150	645.B4S13
400	400	150	645.B4S14

ACCESSORIES

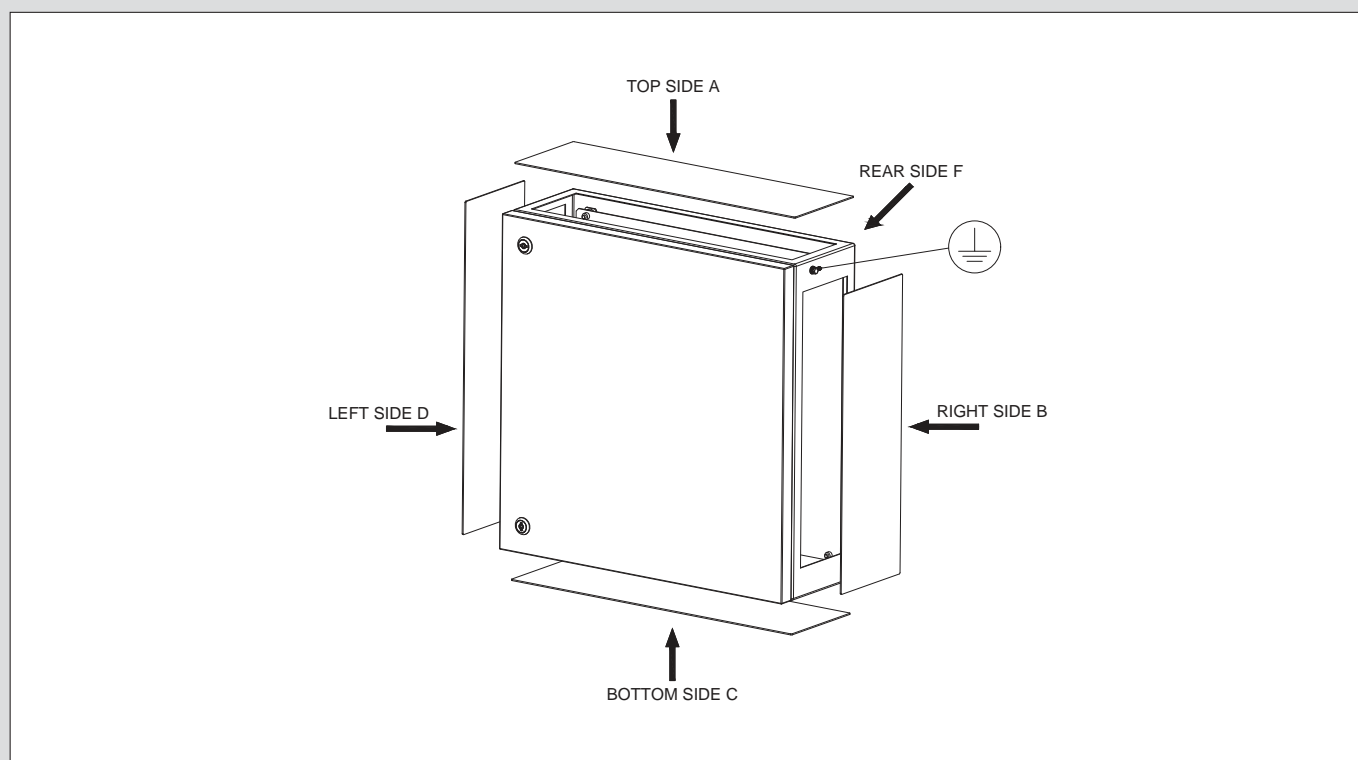

GALVANIZED EARTH PLATE	AISI 304L EARTH PLATE	MOUNTING BRACKETS
-	-	
-	-	
645.B8P03	645.B4P03	
645.B8P04	645.B4P04	
645.B8P05	645.B4P05	
645.B8P06	645.B4P06	
645.B8P07	645.B4P07	
645.B8P08	645.B4P08	645.B4F
645.B8P09	645.B4P09	
645.B8P10	645.B4P10	
645.B8P11	645.B4P11	
645.B8P12	645.B4P12	
645.B8P13	645.B4P13	
645.B8P14	645.B4P14	

645.C - ENCLOSURES GLAND PLATES

Enclosure size (W x H x D)	Top/Bottom sides A/C Lid square	Screw numbers M5x12	Left side -D Lid square	Screw numbers M5x12	Right side -B Lid square	Screw numbers M5x12	Nm
260x260x150	210x70	6	210x70	6	150x70	6	2.5
300x300x210	250x130	8	250x130	8	190x130	8	2.5
300x380x210	250x130	8	330x130	8	270x130	8	2.5
300x450x210	250x130	8	400x130	10	340x130	10	2.5
380x300x210	330x130	8	250x130	8	190x130	8	2.5
380x380x210	330x130	8	330x130	8	270x130	8	2.5
380x600x210	330x130	8	550x130	12	490x130	12	2.5
400x500x210	350x130	10	450x130	10	390x130	10	2.5
450x300x210	400x130	10	250x130	8	190x130	8	2.5
450x450x210	400x130	10	400x130	10	340x130	10	2.5
450x450x250	400x170	10	400x170	10	340x170	10	2.5
450x600x210	400x130	10	550x130	12	490x130	12	2.5
450x600x250	400x170	10	550x170	12	490x170	12	2.5
500x700x250	450x170	10	650x170	12	590x170	12	2.5
600x380x210	550x130	12	330x130	8	270x130	8	2.5
600x450x250	550x170	12	400x170	10	340x170	10	2.5
600x600x210	550x130	12	550x130	12	490x130	12	2.5
600x600x250	550x170	12	550x170	12	490x170	12	2.5
600x600x300	550x220	12	550x220	12	490x220	12	2.5
600x750x210	550x130	12	700x130	14	640x130	14	2.5
600x750x250	550x170	12	700x170	14	640x170	14	2.5
600x750x300	550x220	12	700x220	14	640x220	14	2.5
600x900x300	550x220	12	850x220	16	790x220	16	2.5
750x1000x300	700x220	14	950x220	16	890x220	16	2.5
800x1200x300	750x220	14	1150x220	18	1090x220	18	2.5

ZENITH-S Series

Ex ATEX-IECEX-EAC Ex II 2GD

645.C - MAXIMUM CABLE ENTRIES ENCLOSURES WITHOUT GLAND PLATES

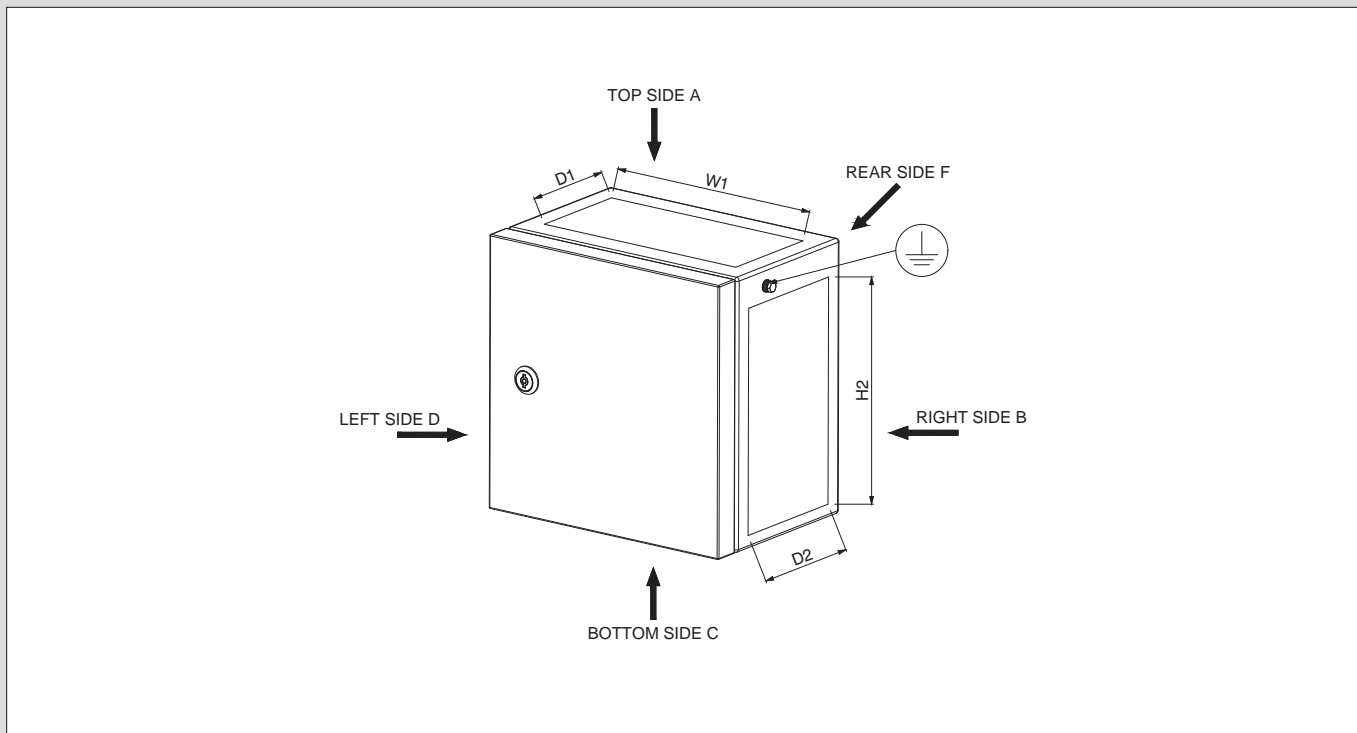

Enclosure size (W x H x D)	Top/Bottom sides A/C									Left/Right sides B/D									Rear side F				
	M12	M16	M20	M25	M32	M40	M50	M63	M75	M12	M16	M20	M25	M32	M40	M50	M63	M75	M16	M20	M25	M32	M40
260x260x150	42	25	21	11	8	4	3	2	2	42	25	21	11	8	4	3	2	2	3	3	3	3	3
300x300x210	66	45	28	22	11	8	6	4	2	66	45	28	22	11	8	6	4	2	3	3	3	3	3
300x380x210	66	45	28	22	11	8	6	4	2	84	55	36	28	16	11	8	5	3	3	3	3	3	3
300x450x210	66	45	28	22	11	8	6	4	2	100	65	44	30	20	14	10	6	4	3	3	3	3	3
380x300x210	84	55	36	28	16	11	8	5	3	66	45	28	22	11	8	6	4	2	3	3	3	3	3
380x380x210	84	55	36	28	16	11	8	5	3	84	55	36	28	16	11	8	5	3	3	3	3	3	3
380x600x210	84	55	36	28	16	11	8	5	3	120	75	60	38	27	17	14	8	5	3	3	3	3	3
400x500x210	90	58	36	28	17	11	8	5	3	102	70	44	34	21	14	10	6	4	3	3	3	3	3
450x300x210	100	65	44	30	20	14	10	6	4	66	45	28	22	11	8	6	4	2	3	3	3	3	3
450x450x210	100	65	44	30	20	14	10	6	4	100	65	44	30	20	14	10	6	4	3	3	3	3	3
450x450x250	120	78	55	36	22	18	11	8	4	120	78	55	36	22	18	11	8	4	3	3	3	3	3
450x600x210	100	65	44	30	20	14	10	6	4	120	75	60	38	27	17	14	8	5	3	3	3	3	3
450x600x250	120	78	55	36	22	18	11	8	4	130	90	70	48	30	24	16	10	5	3	3	3	3	3
500x700x250	120	84	60	40	26	18	12	8	4	150	102	80	52	30	27	17	11	5	3	3	3	3	3
600x380x210	120	75	60	38	27	17	14	8	5	84	55	36	28	16	11	8	5	3	3	3	3	3	3
600x450x250	130	90	70	48	30	24	16	10	5	120	78	55	36	22	18	11	8	4	3	3	3	3	3
600x600x210	120	75	60	38	27	17	14	8	5	120	75	60	38	27	17	14	8	5	3	3	3	3	3
600x600x250	130	90	70	48	30	24	16	10	5	130	90	70	48	30	24	16	10	5	3	3	3	3	3
600x600x300	150	110	82	55	36	25	18	12	6	150	110	82	55	36	25	18	12	6	3	3	3	3	3
600x750x210	120	75	60	38	27	17	14	8	5	150	100	68	42	28	20	16	9	6	4	4	4	4	4
600x750x250	130	90	70	48	30	24	16	10	5	150	120	85	56	35	27	17	14	6	4	4	4	4	4
600x750x300	150	110	82	55	36	25	18	12	6	150	126	96	65	44	33	24	15	6	4	4	4	4	4
600x900x300	150	110	82	55	36	25	18	12	6	150	150	120	80	54	40	27	18	7	4	4	4	4	4
750x1000x300	150	150	100	65	45	30	22	15	8	150	150	150	100	60	42	30	20	8	4	4	4	4	4
800x1200x300	150	150	110	70	50	35	25	17	10	150	150	150	120	70	50	35	22	10	4	4	4	4	4

645.C - MAXIMUM CABLE ENTRIES ENCLOSURES WITH GLAND PLATES

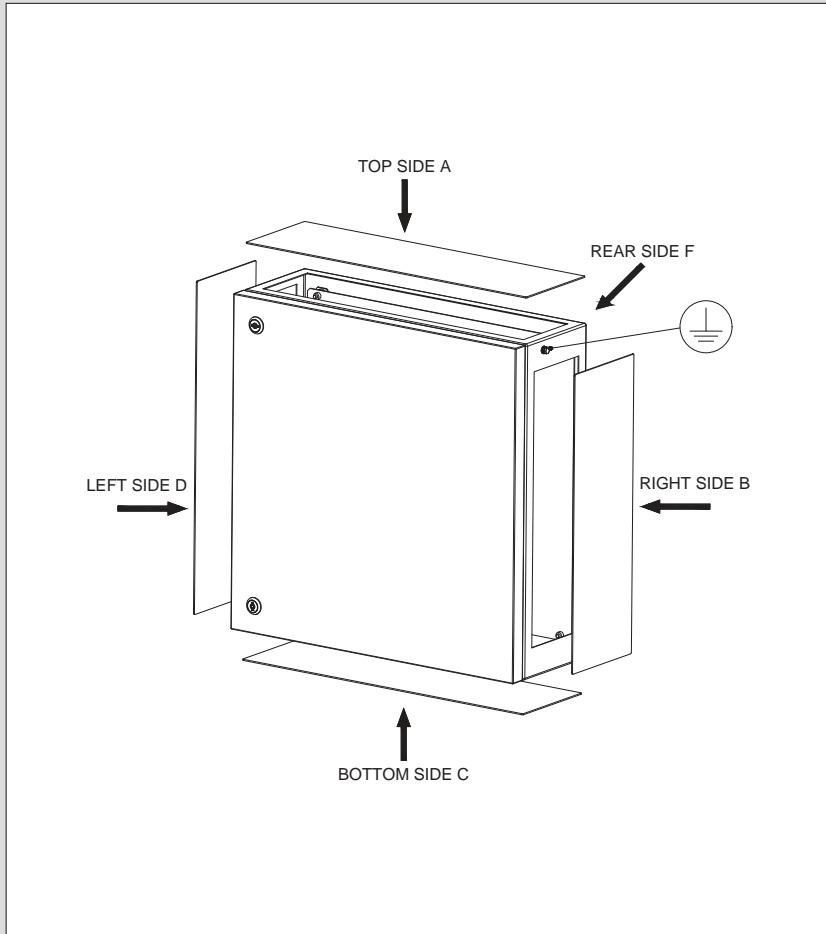

Enclosure size (W x H x D)	Rear side F				
	M16	M20	M25	M32	M40
260x260x150	3	3	3	3	3
300x300x210	3	3	3	3	3
300x380x210	3	3	3	3	3
300x450x210	3	3	3	3	3
380x300x210	3	3	3	3	3
380x380x210	3	3	3	3	3
380x600x210	3	3	3	3	3
400x500x210	3	3	3	3	3
450x300x210	3	3	3	3	3
450x450x210	3	3	3	3	3
450x450x250	3	3	3	3	3
450x600x210	3	3	3	3	3
450x600x250	3	3	3	3	3
500x700x250	3	3	3	3	3
600x380x210	3	3	3	3	3
600x450x250	3	3	3	3	3
600x600x210	3	3	3	3	3
600x600x250	3	3	3	3	3
600x600x300	3	3	3	3	3
600x750x210	4	4	4	4	4
600x750x250	4	4	4	4	4
600x750x300	4	4	4	4	4
600x900x300	4	4	4	4	4
750x1000x300	4	4	4	4	4
800x1200x300	4	4	4	4	4

Enclosure size (W x H x D)	Top/Bottom sides A/C									Left side - B									Right side - D								
	M12	M16	M20	M25	M32	M40	M50	M63	M75	M12	M16	M20	M25	M32	M40	M50	M63	M75	M12	M16	M20	M25	M32	M40	M50	M63	M75
260x260x150	27	14	12	5	3	3	/	/	/	18	11	8	4	2	2	/	/	/	27	14	12	5	3	3	/	/	/
300x300x210	50	28	18	15	8	6	3	2	2	50	28	18	15	8	6	3	2	2	35	24	15	11	6	4	3	2	1
300x380x210	50	28	18	15	8	6	3	2	2	65	40	24	20	10	8	5	3	3	50	32	21	15	8	6	4	3	2
300x450x210	50	28	18	15	8	6	3	2	2	80	48	30	22	14	10	6	4	3	65	40	24	19	12	8	5	4	3
380x300x210	65	40	24	20	10	8	5	3	3	50	28	18	15	8	6	3	2	2	35	24	15	11	6	4	3	2	1
380x380x210	65	40	24	20	10	8	5	3	3	65	40	24	20	10	8	5	3	3	50	32	21	15	8	6	4	3	2
380x600x210	65	40	24	20	10	8	5	3	3	110	68	42	32	18	14	8	6	5	95	60	36	29	16	12	8	5	4
400x500x210	65	40	24	19	12	9	5	3	3	90	56	33	26	14	12	6	5	4	80	48	30	22	12	10	5	4	3
450x300x210	80	48	30	22	14	10	6	4	3	50	28	18	15	8	6	3	2	2	35	24	15	11	6	4	3	2	1
450x450x210	80	48	30	22	14	10	6	4	3	80	48	30	22	14	10	6	4	3	65	40	24	19	12	8	5	4	3
450x450x250	96	60	40	28	18	12	10	6	3	96	60	40	28	18	12	8	6	3	78	50	32	23	15	9	8	5	3
450x600x210	80	48	30	22	14	10	6	4	3	110	68	42	32	18	14	8	6	5	95	60	36	29	16	12	8	5	4
450x600x250	96	60	40	28	18	12	10	6	3	126	80	52	38	26	17	12	8	5	108	70	48	33	23	15	12	7	5
500x700x250	102	65	44	30	21	14	10	6	4	150	100	64	52	31	20	14	9	6	138	90	56	48	28	18	14	8	6
600x380x210	110	68	42	32	18	14	8	6	5	65	40	24	20	10	8	5	3	3	50	32	21	15	8	6	4	3	2
600x450x250	126	80	52	38	26	17	12	8	5	96	60	40	28	18	12	8	6	3	78	50	32	23	15	9	8	5	3
600x600x210	110	68	42	32	18	14	8	6	5	110	68	42	32	18	14	8	6	5	95	60	36	29	16	12	8	5	4
600x600x250	126	80	52	38	26	17	12	8	5	126	80	52	38	26	17	12	8	5	108	70	48	33	23	15	12	7	5
600x600x300	150	103	65	48	30	24	17	11	8	150	103	65	48	30	24	17	11	8	150	90	60	40	28	21	15	9	8
600x750x210	110	68	42	32	18	14	8	6	5	145	84	51	42	24	19	10	7	6	130	80	48	38	22	17	10	7	5
600x750x250	126	80	52	38	26	17	12	8	5	150	105	68	58	34	21	16	10	7	150	100	64	52	31	20	14	9	6
600x750x300	150	103	65	48	30	24	17	11	8	150	126	85	63	38	30	21	14	10	150	116	80	56	35	27	19	12	10
600x900x300	150	103	65	48	30	24	17	11	8	150	150	105	77	45	36	26	17	12	150	150	95	70	43	33	24	15	12
750x1000x300	150	120	90	55	40	30	20	13	8	150	150	130	100	60	40	30	20	12	150	150	130	100	60	40	30	20	12
800x1200x300	150	120	110	65	45	35	25	15	10	150	150	150	120	70	50	35	22	12	150	150	150	120	70	50	35	22	12

ZENITH-S Series

Ex ATEX-IECEx-EAC Ex II 2GD

645.C - BOX DRILLING AREA ENCLOSURES WITH AND WITHOUT GLAND PLATES

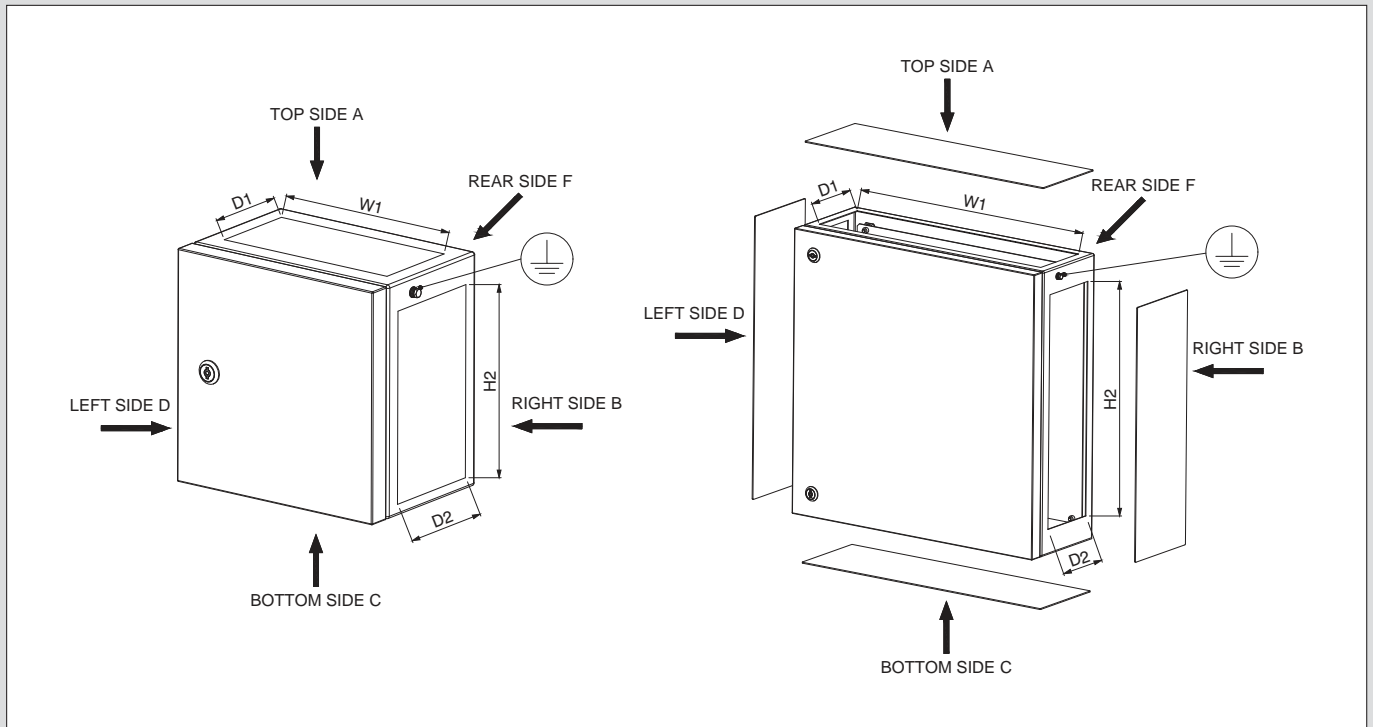

Enclosure size (W x H x D)	Top/Bottom without gland plates sides A/C W1 x D1	Left/Right without gland plates sides B/D H2 x D2	Top/Bottom with gland plates sides A/C W1 x D1	Left sides with gland plates D H2 x D2	Right sides with gland plates B H2 x D2
260x260x150	210x70	250x110	210x70	210x70	150x70
300x300x210	250x130	290x170	250x130	250x130	190x130
300x380x210	250x130	370x170	330x130	330x130	270x130
300x450x210	250x130	440x170	400x130	400x130	340x130
380x300x210	330x130	290x170	250x130	250x130	190x130
380x380x210	330x130	370x170	330x130	330x130	270x130
380x600x210	330x130	590x170	550x130	550x130	490x130
400x500x210	350x130	490x170	450x130	450x130	390x130
450x300x210	400x130	290x170	250x130	250x130	190x130
450x450x210	400x130	440x170	400x130	400x130	340x130
450x450x250	400x170	440x210	400x170	400x170	340x170
450x600x210	400x130	590x170	550x130	550x130	490x130
450x600x250	400x170	590x210	550x170	550x170	490x170
500x700x250	450x170	690x210	650x170	650x170	590x170
600x380x210	550x130	370x170	330x130	330x130	270x130
600x450x250	550x170	440x210	400x170	400x170	340x170
600x600x210	550x130	590x170	550x130	550x130	490x130
600x600x250	550x170	590x210	550x170	550x170	490x170
600x600x300	550x220	590x260	550x220	550x220	490x220
600x750x210	550x130	740x170	700x130	700x130	640x130
600x750x250	550x170	740x210	700x170	700x170	640x170
600x750x300	550x220	740x260	700x220	700x220	640x220
600x900x300	550x220	890x260	850x220	850x220	790x220
750x1000x300	700x220	990x260	950x220	950x220	890x220
800x1200x300	750x220	1190x260	1150x220	1150x220	1090x220

645.C - LID DRILLING AREA

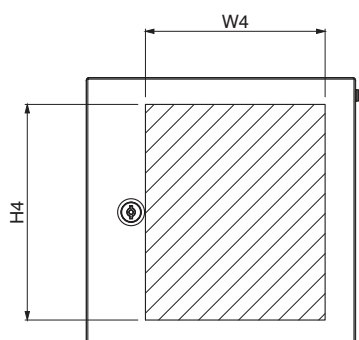

Enclosure size (W x H x D)	Maximum drilling area G (W4 x H4)	Max no. of holes			
		Ø30,5mm	Ø22,5mm	Ø32,5mm	Ø30,8mm - Ø30,6mm with keyway
260x260x150	160x200	6	12	6	6
300x300x210	200x240	8	12	8	9
300x380x210	200x320	12	15	12	12
300x450x210	200x390	15	18	15	15
380x300x210	280x240	12	18	12	15
380x380x210	280x320	16	24	16	20
380x600x210	280x540	28	36	28	35
400x500x210	300x440	24	35	24	30
450x300x210	350x240	15	24	15	18
450x450x210	350x390	25	36	25	30
450x450x250	350x390	25	36	25	30
450x600x210	350x540	35	54	35	42
450x600x250	350x540	35	54	35	42
500x700x250	400x640	44	69	44	63
600x380x210	500x320	28	40	28	36
600x450x250	500x390	35	48	35	45
600x600x210	500x540	49	72	49	63
600x600x250	500x540	49	72	49	63
600x600x300	500x540	49	72	49	63
600x750x210	500x690	63	88	63	81
600x750x250	500x690	63	88	63	81
600x750x300	500x690	63	88	63	81
600x900x300	500x840	77	112	77	100
750x1000x300	650x940	100	150	100	100
800x1200x300	700x1140	120	180	120	120

CLEARANCE AND CREEPAGE

Manufacturer Actuator/Control Components	Maximum Mounting Ø a - (mm)	Minimum distance between two holes b - (mm)	Minimum distance between two holes c - (mm)
SCHNEIDER-ELECTRIC	Ø22,5	35	35
EX-TECH	Ø22,5	35	35
CZ	Ø30,6 (with keyway)	20	40

ZENITH-S Series

 ATEX-IECEx-EAC Ex
II 2GD

645.C - LID SQUARE DRILLING AREA

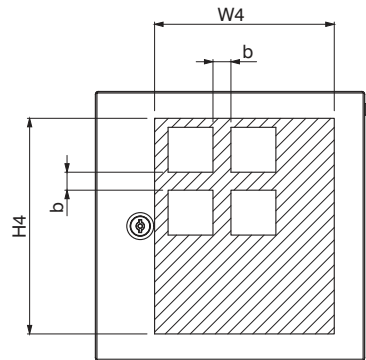

Enclosure size (W x H x D)	Maximum drilling area G (W4 x H4)	Lid square		
		Maximum number	Maximum Size	Minimum distance between two holes b - (mm)
260x260x150	160x200	1	118x95mm	60
300x300x210	200x240	1	118x95mm	60
300x380x210	200x320	2	118x95mm	60
300x450x210	200x390	2	118x95mm	60
380x300x210	280x240	1	118x95mm	60
		1	255x85mm	100
380x380x210	280x320	2	118x95mm	60
		2	255x85mm	100
380x600x210	280x540	3	118x95mm	60
		3	255x85mm	100
400x500x210	300x440	6	118x95mm	60
		2	255x85mm	100
450x300x210	350x240	2	118x95mm	60
		1	255x85mm	100
450x450x210	350x390	4	118x95mm	60
		2	255x85mm	100
450x450x250	350x390	4	118x95mm	60
		2	255x85mm	100
450x600x210	350x540	6	118x95mm	60
		3	255x85mm	100
450x600x250	350x540	6	118x95mm	60
		3	255x85mm	100
500x700x250	400x640	6	118x95mm	60
		3	255x85mm	100
600x380x210	500x320	6	118x95mm	60
		2	255x85mm	100
600x450x250	500x390	6	118x95mm	60
		2	255x85mm	100
600x600x210	500x540	9	118x95mm	60
		3	255x85mm	100
600x600x250	500x540	9	118x95mm	60
		3	255x85mm	100
600x600x300	500x540	9	118x95mm	60
		3	255x85mm	100
600x750x210	500x690	12	118x95mm	60
		4	255x85mm	100
600x750x250	500x690	12	118x95mm	60
		4	255x85mm	100
600x750x300	500x690	12	118x95mm	60
		4	255x85mm	100
600x900x300	500x840	15	118x95mm	60
		4	255x85mm	100
750x1000x300	650x940	15	118x95mm	60
		5	255x85mm	100
800x1200x300	700x1140	18	118x95mm	60
		6	255x85mm	100

■ **EXTERNAL GROUNDING SYSTEM CONNECTION POINTS**

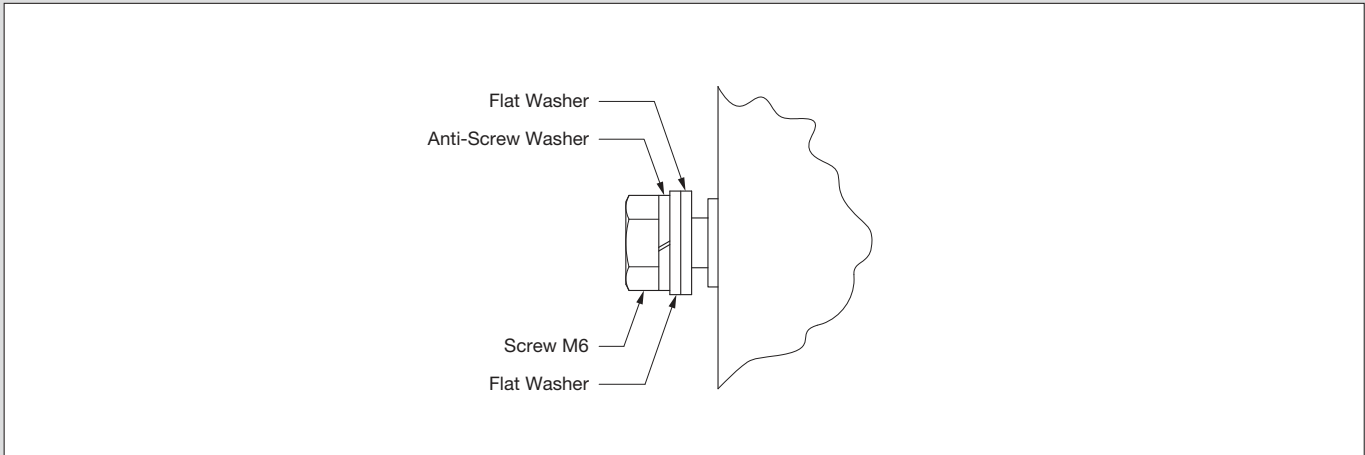

■ **INTERNAL GROUNDING SYSTEM CONNECTION POINTS**

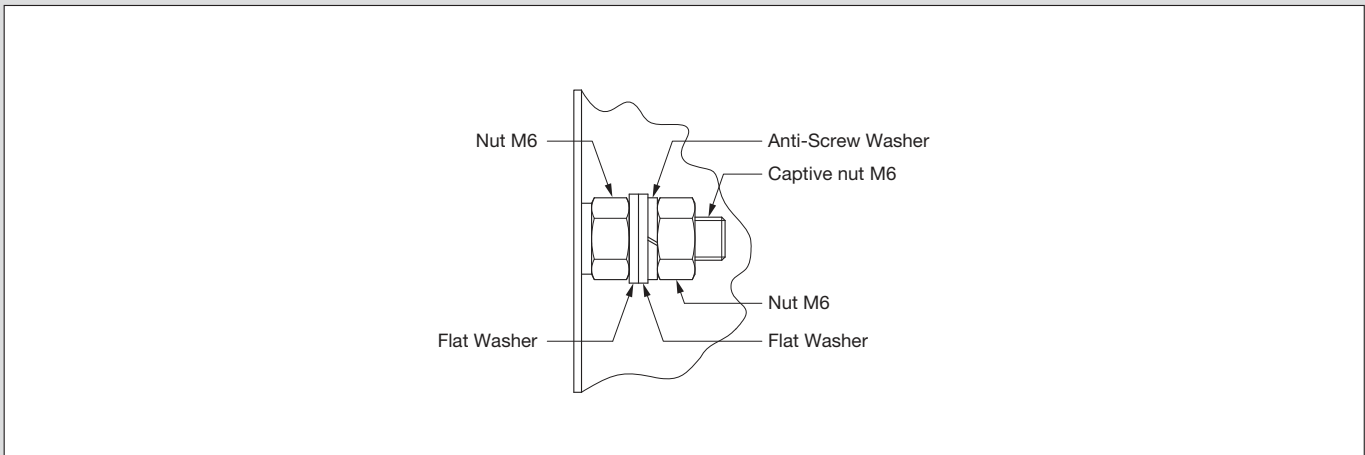

ZENITH-S Series



HINGED LID ENCLOSURES - AISI 316L



W	H	D	AISI 316L ENCLOSURES
260	260	150	645.C6S00 0
	300	210	645.C6S01 0
300	380	210	645.C6S02 0
	450	210	645.C6S03 0
380	300	210	645.C6S04 0
	380	210	645.C6S05 0
	600	210	645.C6S06 0
400	500	210	645.C6S07 0
	300	210	645.C6S08 0
	450	210	645.C6S09 0
450	450	250	645.C6S10 0
	600	210	645.C6S11 0
	600	250	645.C6S12 0
500	700	250	645.C6S13 0
	380	210	645.C6S14 0
	450	250	645.C6S15 0
	600	210	645.C6S16 0
	600	250	645.C6S17 0
600	600	300	645.C6S18 0
	750	210	645.C6S19 0
	750	250	645.C6S20 0
	750	300	645.C6S21 0
750	900	300	645.C6S22 0
	1000	300	645.C6S23 0
800	1200	300	645.C6S24 0

- Standard versions supplied without flange.

- 0 without flange
- 1 1 gland plate bottom
- 2 2 gland plates top/bottom
- 3 3 gland plates bottom/left/right
- 4 4 gland plates top/bottom/left/right

- Standard versions supplied with Yale key.

- For version with lock in AISI 316L add Y at the end of the code: 645.C6S000Y

- For version with lock in Zamak add Z at the end of the code: 645.C6S000Z

- (*) 645.C6FL only for enclosures with lid and flanges.

ACCESSORIES



GALVANIZED EARTH PLATE	AISI 316L EARTH PLATE	MOUNTING BRACKETS
645.C8P00	645.C6P00	
645.C8P01	645.C6P01	
645.C8P02	645.C6P02	
645.C8P03	645.C6P03	
645.C8P02	645.C6P02	
645.C8P05	645.C6P05	
645.C8P06	645.C6P06	
645.C8P07	645.C6P07	
645.C8P03	645.C6P03	
645.C8P09	645.C6P09	
645.C8P09	645.C6P09	
645.C8P11	645.C6P11	
645.C8P11	645.C6P11	645.C6F(*)
645.C8P13	645.C6P13	
645.C8P06	645.C6P06	
645.C8P11	645.C6P11	
645.C8P16	645.C6P16	
645.C8P16	645.C6P16	
645.C8P16	645.C6P16	
645.C8P19	645.C6P19	
645.C8P19	645.C6P19	
645.C8P19	645.C6P19	
645.C8P22	645.C6P22	
645.C8P23	645.C6P23	
645.C8P24	645.C6P24	

DIMENSIONAL REFERENCES

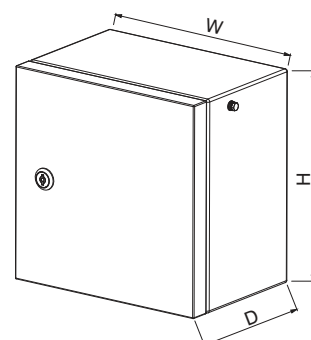

HINGED LID ENCLOSURES - AISI 304L

W	H	D	AISI 304L ENCLOSURES
260	260	150	645.C4S00 0
	300	210	645.C4S01 0
300	380	210	645.C4S02 0
	450	210	645.C4S03 0
380	300	210	645.C4S04 0
	380	210	645.C4S05 0
	600	210	645.C4S06 0
400	500	210	645.C4S07 0
	300	210	645.C4S08 0
	450	210	645.C4S09 0
450	450	250	645.C4S10 0
	600	210	645.C4S11 0
	600	250	645.C4S12 0
	700	250	645.C4S13 0
500	380	210	645.C4S14 0
	450	250	645.C4S15 0
	600	210	645.C4S16 0
	600	250	645.C4S17 0
	600	300	645.C4S18 0
	750	210	645.C4S19 0
	750	250	645.C4S20 0
600	750	300	645.C4S21 0
	900	300	645.C4S22 0
	1000	300	645.C4S23 0
750	1000	300	645.C4S23 0
800	1200	300	645.C4S24 0

- Standard versions supplied without flange.

- 0** without flange
- 1** 1 gland plate bottom
- 2** 2 gland plates top/bottom
- 3** 3 gland plates bottom/left/right
- 4** 4 gland plates top/bottom/left/right

ACCESSORIES

EARTH CONTINUITY PLATE	AISI 304L EARTH PLATE	MOUNTING BRACKETS
645.C8P00	645.C4P00	
645.C8P01	645.C4P01	
645.C8P02	645.C4P02	
645.C8P03	645.C4P03	
645.C8P05	645.C4P05	
645.C8P06	645.C4P06	
645.C8P07	645.C4P07	
645.C8P03	645.C4P03	
645.C8P09	645.C4P09	
645.C8P09	645.C4P09	
645.C8P11	645.C4P11	
645.C8P11	645.C4P11	645.C4F(*)
645.C8P13	645.C4P13	
645.C8P06	645.C4P06	
645.C8P11	645.C4P11	
645.C8P16	645.C4P16	
645.C8P16	645.C4P16	
645.C8P16	645.C4P16	
645.C8P19	645.C4P19	
645.C8P19	645.C4P19	
645.C8P19	645.C4P19	
645.C8P22	645.C4P22	
645.C8P23	645.C4P23	
645.C8P24	645.C4P24	

- Standard versions supplied with Yale key.

- For version with lock in Zamak add Z at the end of the code: 645.C4S000Z

- (*) 645.C4FL only for enclosures with lid and flanges.

ZENITH-S Series



HINGED LID ENCLOSURES - AISI 316L



W	H	D	Key Lock	Mounting brackets	Hinges	Body thickness	WITHOUT GLAND PLATE	1 GLAND PLATE BOTTOM
260	260	150	1	4	2	1,2 mm	645.D6S000	645.D6S001
	300	210	1	4	2	1,2 mm	645.D6S010	645.D6S011
300	380	210	2	4	2	1,2 mm	645.D6S020	645.D6S021
	450	210	2	4	2	1,2 mm	645.D6S030	645.D6S031
380	380	210	2	4	2	1,2 mm	645.D6S050	645.D6S051
400	500	210	2	4	2	1,2 mm	645.D6S070	645.D6S071
450	450	210	2	4	2	1,2 mm	645.D6S090	645.D6S091
	600	210	2	4	3	1,2 mm	645.D6S110	645.D6S111
600	380	210	2	4	3	1,2 mm	645.D6S140	645.D6S141
	600	210	2	4	3	1,2 mm	645.D6S160	645.D6S161
	750	210	2	4	3	1,5 mm	645.D6S190	645.D6S191
	900	300	2	6	3	1,5 mm	645.D6S220	645.D6S221
750	1000	300	2	6	3	1,5 mm	645.D6S230	645.D6S231
800	1200	300	2	6	3	1,5 mm	645.D6S240	645.D6S241

- For version with lock in AISI 316L add Y at the end of the code: 645.D6S000Y.
- For version with lock in Zamak add Z at the end of the code: 645.D6S000Z.
- The mounting brackets are welded.

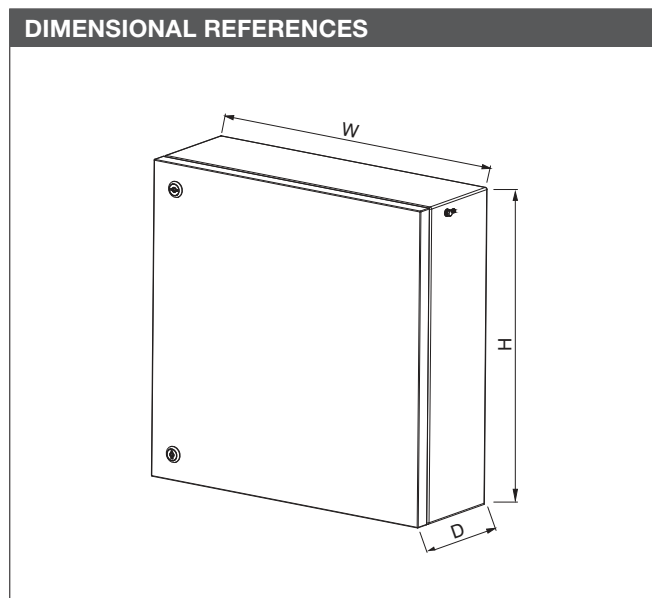



2 GLAND PLATES TOP/ BOTTOM	3 GLAND PLATES BOTTOM/LEFT/RIGHT	3 GLAND PLATES TOP/BOTTOM/LEFT/RIGHT
645.D6S002	645.D6S003	645.D6S004
645.D6S012	645.D6S013	645.D6S014
645.D6S022	645.D6S023	645.D6S024
645.D6S032	645.D6S033	645.D6S034
645.D6S052	645.D6S053	645.D6S054
645.D6S072	645.D6S073	645.D6S074
645.D6S092	645.D6S093	645.D6S094
645.D6S112	645.D6S113	645.D6S114
645.D6S142	645.D6S143	645.D6S144
645.D6S162	645.D6S163	645.D6S164
645.D6S192	645.D6S193	645.D6S194
645.D6S222	645.D6S223	645.D6S224
645.D6S232	645.D6S233	645.D6S234
645.D6S242	645.D6S243	645.D6S244

ACCESSORIES

GALVANIZED EARTH PLATE	AISI 316L EARTH PLATE
645.C8P00	645.C6P00
645.C8P01	645.C6P01
645.C8P02	645.C6P02
645.C8P03	645.C6P03
645.C8P05	645.C6P05
645.C8P07	645.C6P07
645.C8P09	645.C6P09
645.C8P11	645.C6P11
645.C8P06	645.C6P06
645.C8P16	645.C6P16
645.C8P19	645.C6P19
645.C8P22	645.C6P22
645.C8P23	645.C6P23
645.C8P24	645.C6P24

UNION-EX Series





METAL CABLE GLANDS (BY RCN)



The UNION-EX Series in metal consists of a cable gland and RCN branded metal caps, in either nickel-plated brass or AISI 316L stainless steel for armoured or simple cables, with gasket in PTFE, nylon or silicone, and all associated accessories.

VERSIONS

	Cable glands RN version (for unarmoured cable)
	Cable glands RAD version (for armoured cable)

TECHNICAL CHARACTERISTICS

Protection degree:	IP66 - IP66/IP68
Ambient temperature:	-40°C ≤ Ta ≤ +100°C (EDPM) -65°C ≤ Ta ≤ +220°C (silicone)
Material:	Nickel-plated brass, steel AISI316L
Seals:	Silicone, EDPM
Thread:	Metric

REFERENCE STANDARDS

ATEX IECEX	IEC/EN 60079-0 Electrical apparatus for potentially explosive atmospheres. <i>Part 0: General requirements.</i>
ATEX IECEX	IEC/EN 60079-1 Electrical apparatus for potentially explosive atmospheres. <i>Part 1: equipment protection by flameproof enclosures "d".</i>
ATEX IECEX	IEC/EN 60079-7 Electrical apparatus for potentially explosive atmospheres. <i>Part 7: equipment protection by increased safety "e".</i>
ATEX IECEX	IEC/EN 60079-31 Electrical apparatus for potentially explosive atmospheres. <i>Part 31: Protection by enclosures "t".</i>

Ex CHARACTERISTICS

ATEX Category:	Ⓔ II 2GD / IM2
Ex Protection type:	Ex db I Mb Ex eb I Mb Ex db IIC Gb Ex eb IIC Gb Ex nR IIC Gc Ex tb IIIC Db
ATEX Certificate:	INERIS 06ATEX0014X
IECEX Certificate:	IECEX INE 10.0010X
EAC Ex Certificate:	RU C-IT.A45.B.00081

POLYAMIDE CABLE GLANDS (BY SIB)



The UNION-EX Series in polyamide consists of a cable gland and SIB (Schlemmer) branded polyamide caps in black or blue, and all associated accessories.

VERSIONS



Long thread, short thread and with reducer-seal inserts cable glands

TECHNICAL CHARACTERISTICS

Protection degree:	IP66/IP68
Ambient temperature:	M12: -20°C ≤ Ta ≤ +80°C M16-M63: -35°C ≤ Ta ≤ +95°C
Material:	Polyamide
Colour:	RAL 9005 (Black) RAL 5012 (Blue)
Seals:	EDPM
Thread:	Metric

REFERENCE STANDARDS

ATEX IECEX	IEC/EN 60079-0 Electrical apparatus for potentially explosive atmospheres. <i>Part 0: General requirements.</i>
ATEX IECEX	IEC/EN 60079-7 Electrical apparatus for potentially explosive atmospheres. <i>Part 7: equipment protection by increased safety "e".</i>
ATEX IECEX	IEC/EN 60079-31 Electrical apparatus for potentially explosive atmospheres. <i>Part 31: Protection by enclosures "t".</i>

Ex CHARACTERISTICS

ATEX Category:	Ex II 2GD
Ex Protection type:	Ex eb IIC Ex tb IIIC
ATEX Certificate:	LCIE 07 ATEX 6082 X
IECEX Certificate:	LCI 10.0008 X
INMETRO Certificate:	BR 230661-X
EAC Ex Certificate:	RU C-FR.ГБ05.B.00955

UNION-EX Series



METAL CABLE GLANDS FOR UNARMoured CABLE RN VERSION (KIT)

EPDM seal



Size	Thread	A Ø min-max (mm)	C1	C2	☐	NICKEL-PLATED BRASS	STEEL S6
16	M12x1.5	4÷7 7÷10	24	24	1	805.RN1612.EN	805.RN1612.ES
	M16x1.5		24	24	1	805.RN1616.EN	805.RN1616.ES
	M20x1.5		24	24	1	805.RN1620.EN	805.RN1620.ES
20	M16x1.5	5,5÷8 8÷10,5 10,5÷13	30	32	1	805.RN2016.EN	805.RN2016.ES
	M20x1.5		30	32	1	805.RN2020.EN	805.RN2020.ES
	M25x1.5		30	32	1	805.RN2025.EN	805.RN2025.ES
25	M20x1.5	8÷10,5 - 10,5÷13 13÷15,5 - 15,5÷18	35	36	1	805.RN2520.EN	805.RN2520.ES
	M25x1.5		35	36	1	805.RN2525.EN	805.RN2525.ES
32	M25x1.5	13÷15,5 - 15÷18 18÷21 - 21÷24	42	45	1	805.RN3225.EN	805.RN3225.ES
	M32x1.5		42	45	1	805.RN3232.EN	805.RN3232.ES
40	M40x1.5	21÷24 - 24÷27 - 27÷30	48	50	1	805.RN4040.EN	805.RN4040.ES
50	M40x1.5	24÷27 - 27÷30 30÷33 - 33÷36	55	57	1	805.RN5040.EN	805.RN5040.ES
	M50x1.5		55	57	1	805.RN5050.EN	805.RN5050.ES
63	M50x1.5	36÷39 - 39÷42 42÷45	68	67	1	805.RN6350.EN	805.RN6350.ES
	M63x1.5		68	67	1	805.RN6363.EN	805.RN6363.ES
75	M63x1.5	45÷48 - 48÷51 51÷54	80	80	1	805.RN7563.EN	805.RN7563.ES
	M75x1.5		80	80	1	805.RN7575.EN	805.RN7575.ES
90	M75x1.5	54÷58 - 58÷62 60÷64 - 64÷68	100	100	1	805.RN9075.EN	805.RN9075.ES
	M90x1.5		100	100	1	805.RN9090.EN	805.RN9090.ES
91	M75x1.5	54÷58 - 58÷62 60÷64 - 64÷68	100	100	1	805.RN9175.EN	805.RN9175.ES
	M90x1.5		100	100	1	805.RN9190.EN	805.RN9190.ES

☐ Package/Bulk Pack. Standard size

CABLE GLANDS

Cable glands for non-armoured cable with seal outside the cable.

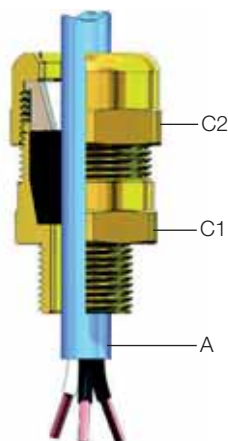

SILICONE seal



Size	Thread	A Ø min-max (mm)	C1	C2	□	NICKEL-PLATED BRASS	STEEL S6
						805.RN1612.SN	805.RN1612.SS
16	M12x1.5	4÷6 - 6÷8 8÷10	24	24	1	805.RN1612.SN	805.RN1612.SS
	M16x1.5		24	24	1	805.RN1616.SN	805.RN1616.SS
	M20x1.5		24	24	1	805.RN1620.SN	805.RN1620.SS
20	M16x1.5	5,5÷8 - 8÷10,5 10,5÷13	30	32	1	805.RN2016.SN	805.RN2016.SS
	M20x1.5		30	32	1	805.RN2020.SN	805.RN2020.SS
	M25x1.5		30	32	1	805.RN2025.SN	805.RN2025.SS
25	M20x1.5	8÷10,5 - 10,5÷13 13÷15,5 - 15,5÷18	35	36	1	805.RN2520.SN	805.RN2520.SS
	M25x1.5		35	36	1	805.RN2525.SN	805.RN2525.SS
32	M25x1.5	13÷15,5 - 15÷18 18÷21 - 21÷24	42	45	1	805.RN3225.SN	805.RN3225.SS
	M32x1.5		42	45	1	805.RN3232.SN	805.RN3232.SS
40	M40x1.5	21÷24 - 24÷27 - 27÷30	48	50	1	805.RN4040.SN	805.RN4040.SS
50	M40x1.5	24÷27 - 27÷30 30÷33 - 33÷36	55	57	1	805.RN5040.SN	805.RN5040.SS
	M50x1.5		55	57	1	805.RN5050.SN	805.RN5050.SS
63	M50x1.5	36÷39 - 39÷42 42÷45	68	67	1	805.RN6350.SN	805.RN6350.SS
	M63x1.5		68	67	1	805.RN6363.SN	805.RN6363.SS
75	M63x1.5	45÷48 - 48÷51 51÷54	80	80	1	805.RN7563.SN	805.RN7563.SS
	M75x1.5		80	80	1	805.RN7575.SN	805.RN7575.SS
90	M75x1.5	54÷58 - 58÷62 60÷64 - 64÷68	100	100	1	805.RN9075.SN	805.RN9075.SS
	M90x1.5		100	100	1	805.RN9090.SN	805.RN9090.SS
91	M75x1.5	54÷58 - 58÷62 60÷64 - 64÷68	100	100	1	805.RN9175.SN	805.RN9175.SS
	M90x1.5		100	100	1	805.RN9190.SN	805.RN9190.SS

□ Package/Bulk Pack. ■ Standard size

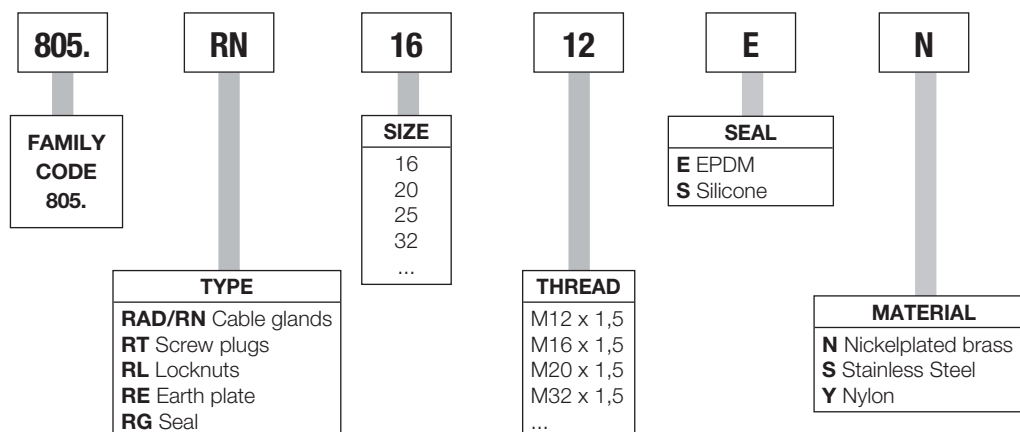
CODE STRUCTURE

UNION-EX Series



METAL CABLE GLANDS FOR ARMoured CABLE RAD VERSION (KIT)

EPDM seal



Size	Thread	A Ø min-max cable under armour (mm)	B Ø min-max external cable	C1 🔧	C2 🔧	📦	NICKEL-PLATED BRASS	STEEL S6
16	M12x1.5			24	24	1	805.RAD1612.EN	805.RAD1612.ES
	M16x1.5	4÷7 7÷10	5÷10 10÷15	24	24	1	805.RAD1616.EN	805.RAD1616.ES
	M20x1.5			24	24	1	805.RAD1620.EN	805.RAD1620.ES
20	M16x1.5			30	32	1	805.RAD2016.EN	805.RAD2016.ES
	M20x1.5	5,5÷8 8÷10,5 10,5÷13	10÷15 14÷19	30	32	1	805.RAD2020.EN	805.RAD2020.ES
	M25x1.5			30	32	1	805.RAD2025.EN	805.RAD2025.ES
25	M20x1.5	8÷10,5 - 10,5÷13	15÷20	35	36	1	805.RAD2520.EN	805.RAD2520.ES
	M25x1.5	13÷15,5 - 15,5÷18	19÷24	35	36	1	805.RAD2525.EN	805.RAD2525.ES
32	M25x1.5	13÷15,5 - 15÷18	20÷26	42	45	1	805.RAD3225.EN	805.RAD3225.ES
	M32x1.5	18÷21 - 21÷24	25÷31	42	45	1	805.RAD3232.EN	805.RAD3232.ES
40	M40x1.5	21÷24 - 24÷27 - 27÷30	26÷32 - 31÷37	48	50	1	805.RAD4040.EN	805.RAD4040.ES
50	M40x1.5	24÷27 - 27÷30	31÷37	55	57	1	805.RAD5040.EN	805.RAD5040.ES
	M50x1.5	30÷33 - 33÷36	36÷43	55	57	1	805.RAD5050.EN	805.RAD5050.ES
63	M50x1.5	36÷39 - 39÷42	42÷48	68	67	1	805.RAD6350.EN	805.RAD6350.ES
	M63x1.5	42÷45	47÷53	68	67	1	805.RAD6363.EN	805.RAD6363.ES
75	M63x1.5	45÷48 - 48÷51	52÷58	80	80	1	805.RAD7563.EN	805.RAD7563.ES
	M75x1.5	51÷54	52÷64	80	80	1	805.RAD7575.EN	805.RAD7575.ES
90	M75x1.5			100	100	1	805.RAD9075.EN	805.RAD9075.ES
	M90x1.5	54÷58 - 58÷62	64÷72	100	100	1	805.RAD9090.EN	805.RAD9090.ES
91	M75x1.5	60÷64 - 64÷68	70÷78	100	100	1	805.RAD9175.EN	805.RAD9175.ES
	M90x1.5			100	100	1	805.RAD9190.EN	805.RAD9190.ES

📦 Package/Bulk Pack. Standard size

CABLE GLANDS

Cable glands for armoured cable, locking under the armour and outside.
Earthing of the armour.

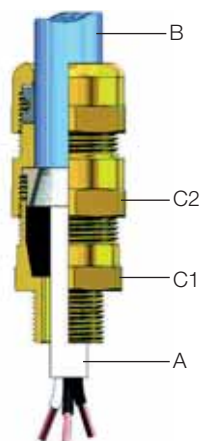

SILICONE seal



Size	Thread	A Ø min-max cable under armour (mm)	B Ø min-max external cable	C1	C2	□	NICKEL-PLATED BRASS	STEEL S6
							805.RAD1612.SN	805.RAD1612.SS
16	M12x1.5	4÷6 - 6÷8 8÷10	5÷10 10÷15	24	24	1	805.RAD1612.SN	805.RAD1612.SS
	M16x1.5			24	24	1	805.RAD1616.SN	805.RAD1616.SS
	M20x1.5			24	24	1	805.RAD1620.SN	805.RAD1620.SS
20	M16x1.5	5,5÷8 8÷10,5 10,5÷13	10÷15 14÷19	30	32	1	805.RAD2016.SN	805.RAD2016.SS
	M20x1.5			30	32	1	805.RAD2020.SN	805.RAD2020.SS
	M25x1.5			30	32	1	805.RAD2025.SN	805.RAD2025.SS
25	M20x1.5	8÷10,5 - 10,5÷13 13÷15,5 - 15,5÷18	15÷20 19÷24	35	36	1	805.RAD2520.SN	805.RAD2520.SS
	M25x1.5			35	36	1	805.RAD2525.SN	805.RAD2525.SS
32	M25x1.5	13÷15,5 - 15÷18 18÷21 - 21÷24	20÷26 25÷31	42	45	1	805.RAD3225.SN	805.RAD3225.SS
	M32x1.5			42	45	1	805.RAD3232.SN	805.RAD3232.SS
40	M40x1.5	21÷24 - 24÷27 - 27÷30	26÷32 - 31÷37	48	50	1	805.RAD4040.SN	805.RAD4040.SS
50	M40x1.5	24÷27 - 27÷30 30÷33 - 33÷36	31÷37 36÷43	55	57	1	805.RAD5040.SN	805.RAD5040.SS
	M50x1.5			55	57	1	805.RAD5050.SN	805.RAD5050.SS
63	M50x1.5	36÷39 - 39÷42 42÷45	42÷48 47÷53	68	67	1	805.RAD6350.SN	805.RAD6350.SS
	M63x1.5			68	67	1	805.RAD6363.SN	805.RAD6363.SS
75	M63x1.5	45÷48 - 48÷51 51÷54	52÷58 52÷64	80	80	1	805.RAD7563.SN	805.RAD7563.SS
	M75x1.5			80	80	1	805.RAD7575.SN	805.RAD7575.SS
90	M75x1.5	54÷58 - 58÷62 60÷64 - 64÷68	64÷72 70÷78	100	100	1	805.RAD9075.SN	805.RAD9075.SS
	M90x1.5			100	100	1	805.RAD9090.SN	805.RAD9090.SS
91	M75x1.5	60÷64 - 64÷68	70÷78	100	100	1	805.RAD9175.SN	805.RAD9175.SS
	M90x1.5			100	100	1	805.RAD9190.SN	805.RAD9190.SS

□ Package/Bulk Pack. ■ Standard size

EXAMPLE KIT

 RAD/RN cable gland kit consisting of a set of rubber pads.
The kit is supplied without locknut and seal.
EXAMPLE OF CABLE GLAND KIT LABEL

CABLE GLAND IP66/68

KIT.RAD20.N20.FP.ON

 Cod. cliente: 805.RAD1612.EN
 KIT pressacavo RAD size 20 M 1/2" NPT ottone nichelato
 Lotto: 014929

8 001636 4 10876

Marcatura:

 RCN RAD20 1/2 NPT **CE** 0080 INERS 06ATEX0014X IEC Ex INE10.0010X
 © IM2 Exel-Exdl/II2GD Exell-ExdlIC-ExtD A21 IP66/68



UNION-EX Series

 ATEX-IECEX-EAC Ex
II 2GD

SCREW PLUGS



Thread		NICKEL-PLATED BRASS	STEEL S6
M12x1.5	1	805.RT12.N	805.RT12.S
M16x1.5	1	805.RT16.N	805.RT16.S
M20x1.5	1	805.RT20.N	805.RT20.S
M25x1.5	1	805.RT25.N	805.RT25.S
M32x1.5	1	805.RT32.N	805.RT32.S
M40x1.5	1	805.RT40.N	805.RT40.S
M50x1.5	1	805.RT50.N	805.RT50.S
M63x1.5	1	805.RT63.N	805.RT63.S
M75x1.5	1	805.RT75.N	805.RT75.S
M90x2	1	805.RT90.N	805.RT90.S

 Package/Bulk Pack.
- Without seal

LOCKNUTS



Thread		NICKEL-PLATED BRASS	STEEL S6
M12x1.5	10	805.RL12.N	805.RL12.S
M16x1.5	10	805.RL16.N	805.RL16.S
M20x1.5	10	805.RL20.N	805.RL20.S
M25x1.5	10	805.RL25.N	805.RL25.S
M32x1.5	10	805.RL32.N	805.RL32.S
M40x1.5	10	805.RL40.N	805.RL40.S
M50x1.5	10	805.RL50.N	805.RL50.S
M63x1.5	10	805.RL63.N	805.RL63.S
M75x1.5	10	805.RL75.N	805.RL75.S
M90x2	10	805.RL90.N	805.RL90.S

 Package/Bulk Pack.

EARTHING TAGS



Type	☐	NICKEL-PLATED BRASS	STEEL S6
M12	10	805.RE12.N	805.RE12.S
M16	10	805.RE16.N	805.RE16.S
M20	10	805.RE20.N	805.RE20.S
M25	10	805.RE25.N	805.RE25.S
M32	10	805.RE32.N	805.RE32.S
M40	10	805.RE40.N	805.RE40.S
M50	10	805.RE50.N	805.RE50.S
M63	10	805.RE63.N	805.RE63.S
M75	10	805.RE75.N	805.RE75.S
M90	10	805.RE90.N	805.RE90.S

☐ Package/Bulk Pack.

SEALS



Type	☐	NYLON	SILICONE
M12	10	805.RG12.Y	805.RG12.S
M16	10	805.RG16.Y	805.RG16.S
M20	10	805.RG20.Y	805.RG20.S
M25	10	805.RG25.Y	805.RG25.S
M32	10	805.RG32.Y	805.RG32.S
M40	10	805.RG40.Y	805.RG40.S
M50	10	805.RG50.Y	805.RG50.S
M63	10	805.RG63.Y	805.RG63.S
M75	10	805.RG75.Y	805.RG75.S
M90	10	805.RG90.Y	805.RG90.S

☐ Package/Bulk Pack.

CABLE GLAND SHROUD PROTECTION



Size	☐	PVC	EPDM
16	1/10	805.RS16	
20	1/10	805.RS20	
25	1/10	805.RS25	
32	1/10	805.RS32	
40	1/10	805.RS40	
50	1/10	805.RS50	
63	1/10	805.RS63	
75	1/10		805.RS75.EP
90a/b	1/10		805.RS90.EP

☐ Package/Bulk Pack.

UNION-EX Series

 ATEX-IECEX-EAC Ex
II 2GD

POLYAMIDE CABLE GLANDS



Thread	Ø cable min-max	□	SHORT THREAD		LONG THREAD	
			BLACK	BLUE	BLACK	BLUE
M12x1.5	4.5 - 6.5	50	805.EX5412.K	805.EX5412.B	805.EX5512.K	805.EX5512.B
M16x1.5	5.0 - 8.0	50	805.EX5416.K	805.EX5416.B	805.EX5516.K	805.EX5516.B
	5.0 - 10.0	50	805.EX5417.K	805.EX5417.B	805.EX5517.K	805.EX5517.B
M20x1.5	7.0 - 12.0	50	805.EX5420.K	805.EX5420.B	805.EX5520.K	805.EX5520.B
	10.0 - 14.0	50	805.EX5421.K	805.EX5421.B	805.EX5521.K	805.EX5521.B
M25x1.5	10.0 - 14.0	50	805.EX5425.K	805.EX5425.B	805.EX5525.K	805.EX5525.B
	12.0 - 18.0	25	805.EX5426.K	805.EX5426.B	805.EX5526.K	805.EX5526.B
M32x1.5	16.0 - 25.0	20	805.EX5432.K	805.EX5432.B	805.EX5532.K	805.EX5532.B
M40x1.5	22.0 - 32.0	10	805.EX5440.K	805.EX5440.B	805.EX5540.K	805.EX5540.B
M50x1.5	28.0 - 38.5	5	805.EX5450.K	805.EX5450.B	805.EX5550.K	805.EX5550.B
M63x1.5	40.0 - 48.0	5	805.EX5463.K	805.EX5463.B	805.EX5563.K	805.EX5563.B

□ Package/Bulk Pack.

- With seal



Thread	Ø cable min-max	☐	SHORT THREAD WITH REDUCED SEAL		LONG THREAD WITH REDUCED SEAL	
			BLACK	BLUE	BLACK	BLUE
M12x1.5	3.0 - 5.0	50	805.EX5412.KR	805.EX5412.BR	805.EX5512.KR	805.EX5512.BR
M16x1.5	4.0 - 6.0	50	805.EX5416.KR	805.EX5416.BR	805.EX5516.KR	805.EX5516.BR
	4.0 - 7.0	50	805.EX5417.KR	805.EX5417.BR	805.EX5517.KR	805.EX5517.BR
M20x1.5	5.0 - 9.0	50	805.EX5420.KR	805.EX5420.BR	805.EX5520.KR	805.EX5520.BR
	8.0 - 12.0	50	805.EX5421.KR	805.EX5421.BR	805.EX5521.KR	805.EX5521.BR
M25x1.5	8.0 - 12.0	50	805.EX5425.KR	805.EX5425.BR	805.EX5525.KR	805.EX5525.BR
	10.0 - 16.0	25	805.EX5426.KR	805.EX5426.BR	805.EX5526.KR	805.EX5526.BR
M32x1.5	14.0 - 21.0	20	805.EX5432.KR	805.EX5432.BR	805.EX5532.KR	805.EX5532.BR
M40x1.5	16.0 - 26.0	10	805.EX5440.KR	805.EX5440.BR	805.EX5540.KR	805.EX5540.BR
M50x1.5	20.0 - 31.0	5	805.EX5450.KR	805.EX5450.BR	805.EX5550.KR	805.EX5550.BR
M63x1.5	30.0 - 39.0	5	805.EX5463.KR	805.EX5463.BR	805.EX5563.KR	805.EX5563.BR

☐ Package/Bulk Pack.
- With seal

CODE STRUCTURE

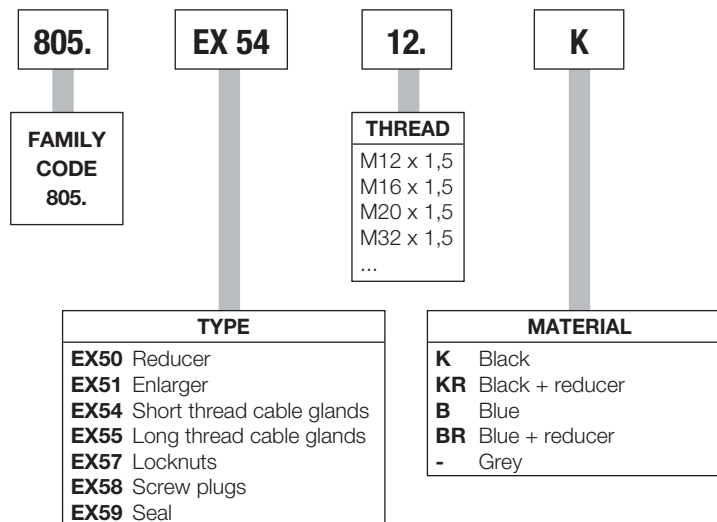

UNION-EX Series



ENLARGER



Thread Male – Female		GREY	BLACK
M12x1.5 - M16x1.5	50	805.EX5112	805.EX5112.K
M16x1.5 - M20x1.5	50	805.EX5116	805.EX5116.K
M20x1.5 - M25x1.5	50	805.EX5120	805.EX5120.K
M25x1.5 - M32x1.5	20	805.EX5125	805.EX5125.K
M32x1.5 - M40x1.5	20	805.EX5132	805.EX5132.K
M40x1.5 - M50x1.5	20	805.EX5140	805.EX5140.K
M50x1.5 - M63x1.5	10	805.EX5150	805.EX5150.K

☐ Package/Bulk Pack.
- With neoprene seal

REDUCER



Thread Male – Female		GREY	BLACK
M16x1.5 - M12x1.5	50	805.EX5016	805.EX5016.K
M20x1.5 - M16x1.5	50	805.EX5020	805.EX5020.K
M25x1.5 - M20x1.5	50	805.EX5025	805.EX5025.K
M32x1.5 - M25x1.5	25	805.EX5032	805.EX5032.K
M40x1.5 - M32x1.5	10	805.EX5040	805.EX5040.K
M50x1.5 - M40x1.5	10	805.EX5050	805.EX5050.K
M63x1.5 - M50x1.5	10	805.EX5063	805.EX5063.K

☐ Package/Bulk Pack.
- With neoprene seal

LOCKNUTS

Thread	☐	GREY	BLACK
M12x1.5	50	805.EX5712	805.EX5712.K
M16x1.5	50	805.EX5716	805.EX5716.K
M20x1.5	50	805.EX5720	805.EX5720.K
M25x1.5	50	805.EX5725	805.EX5725.K
M32x1.5	50	805.EX5732	805.EX5732.K
M40x1.5	20	805.EX5740	805.EX5740.K
M50x1.5	10	805.EX5750	805.EX5750.K
M63x1.5	5	805.EX5763	805.EX5763.K

☐ Package/Bulk Pack.

SCREW PLUGS



Thread	☐	GREY	BLACK
M12x1.5	50	805.EX5812	805.EX5812.K
M16x1.5	50	805.EX5816	805.EX5816.K
M20x1.5	50	805.EX5820	805.EX5820.K
M25x1.5	25	805.EX5825	805.EX5825.K
M32x1.5	15	805.EX5832	805.EX5832.K
M40x1.5	10	805.EX5840	805.EX5840.K
M50x1.5	10	805.EX5850	805.EX5850.K
M63x1.5	10	805.EX5863	805.EX5863.K

☐ Package/Bulk Pack.
- With neoprene seal

SEALS

Type	☐	NEOPRENE	SILICONE
M12	50	805.EX5912	805.EX5912.S
M16	50	805.EX5916	805.EX5916.S
M20	50	805.EX5920	805.EX5920.S
M25	20	805.EX5925	805.EX5925.S
M32	20	805.EX5932	805.EX5932.S
M40	20	805.EX5940	805.EX5940.S
M50	10	805.EX5950	805.EX5950.S
M63	5	805.EX5963	805.EX5963.S

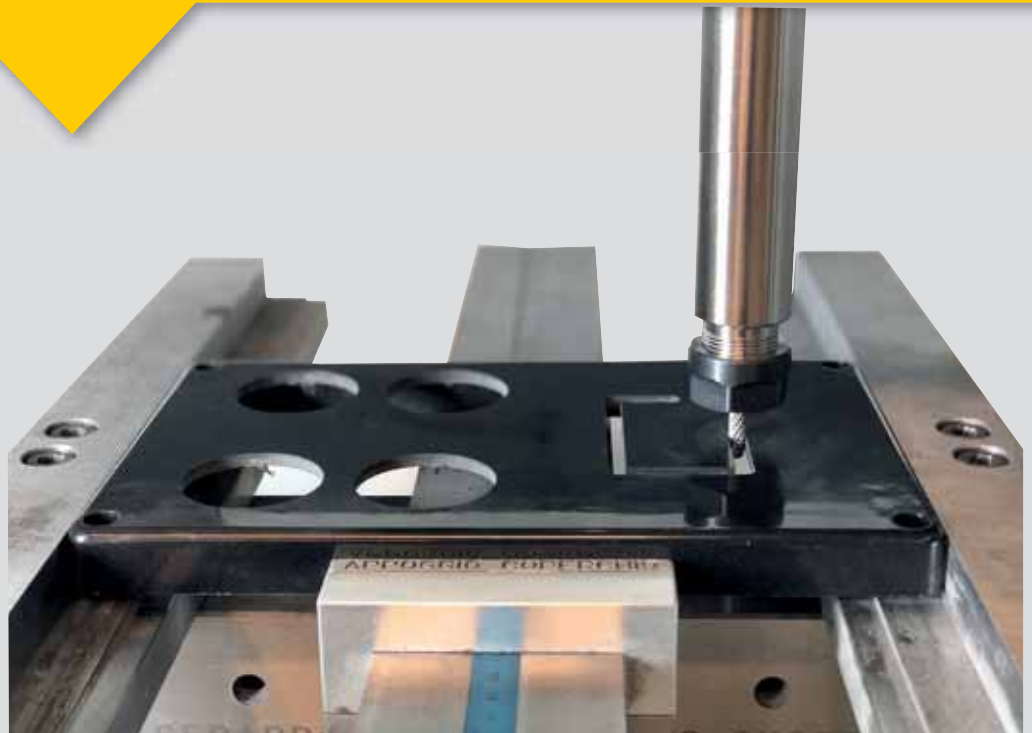
☐ Package/Bulk Pack.



Customised Solutions

Scame has **ATEX** and **IECEX** certification.

An efficient in-house analysis and quoting service is able to support clients during the decision-making process, generating offers and feasibility studies in a short time.

Thanks to production flexibility based on the principles of Lean Production and the use of highly qualified personnel and leading edge machinery, the company is able to develop junction boxes and control stations in customised configurations based on client specifications, without necessarily the need for large production batches.

Skid-assemblies, which are also the result of careful design and development, are available for applications in the presence of gases, vapours, mists and dust generated by production processes, where the choice of material and certified components proves critical, especially in relation to the temperature class.

Offering the possibility for configuration according to client specifications and easy and rapid installation without extended downtime, the skid-assemblies proposed by Scame are based on the use of equipment mounted on sturdy base plates, sized to guarantee the correct distance between the various components so that their maximum surface temperature is lower than the ignition temperature of the substance present.



1

ATEX-IECEX-EAC Ex [Ex II 2GD]

- Zone 1 (Gb)
- Zone 2 (Gc)
- Zone 21 (Db)
- Zone 22 (Dc)

ADVANCE-GRP[GD] Series

 ATEX-IECEX-EAC Ex II 2GD

DIMENSIONS

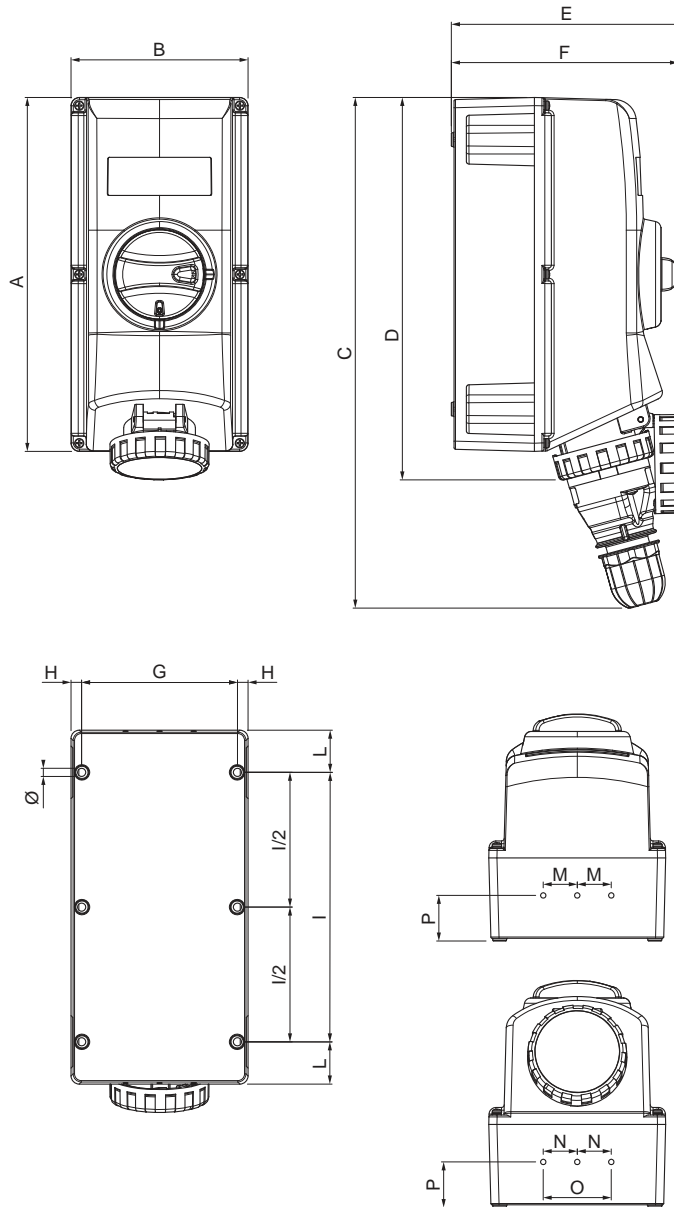

	TYPE	A	B	C min	D	E	F	G	H	Ø	I	I/2	L	M	N	O	P
16A	2P+E	260	130	370	280	170	166,8	114,5	7,75	6	198		31	25	25		33,5
	3P+E	260	130	375	282	175	166,8	114,5	7,75	6	198		31	25	25		33,5
	3P+N+E	260	130	393	282	182	166,8	114,5	7,75	6	198		31	25	25		33,5
32A	2P+E	260	130	395	285	189	166,8	114,5	7,75	6	198		31	25	25		33,5
	3P+E	260	130	395	285	189	166,8	114,5	7,75	6	198		31	25	25		33,5
	3P+N+E	260	130	403	286	185	166,8	114,5	7,75	6	198		31	25	25		33,5
63A	3P+E	380	170	550	420	225	205,75	150	8,3	7	310		35	32,5	32,5		40
	3P+N+E	380	170	550	420	225	205,75	150	8,3	7	310		35	32,5	32,5		40
125A	3P+E	575	280	800	626	253	250	257	11,5	9	468		54	50		130	49
	3P+N+E	575	280	800	626	253	250	257	11,5	9	468	234	54	50		130	49

DIMENSIONS

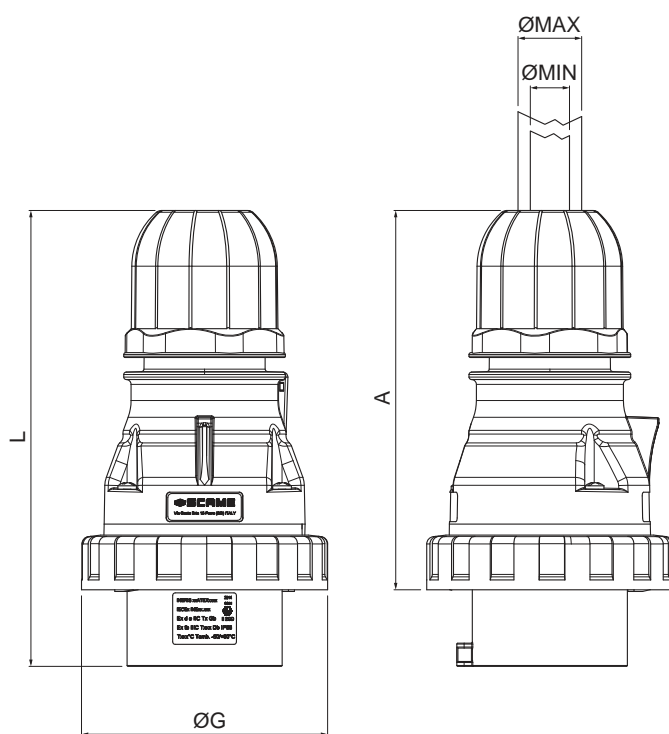

IP66	TYPE	A Min	øG	L Min	ø Min	ø Max
	2P+E	116	73	140,5	6	15
16A	3P+E	123	81	147,5	6	15
	3P+N+E	140,5	88	165	9	20
32A	2P+E	142,6	92	174	9	20
	3P+E	142,6	92	174	9	20
63A	3P+N+E	150	101	180,5	13	23
	3P+E	166,5	112	217,5	17	33
125A	3P+N+E	166,5	112	217,5	17	33
	3P+E	214,5	128	274	26	50
	3P+N+E	214,5	128	274	26	50

ISOLATORS-EX[GD] Series

Ex ATEX-IECEX-EAC Ex II 2GD

DIMENSIONS

THERMOSETTING ENCLOSURE 20A, 25A, 32A

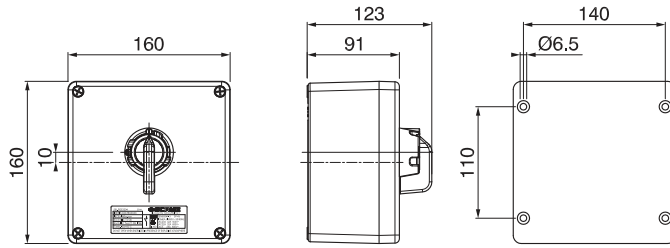

THERMOSETTING ENCLOSURE 40A, 63A

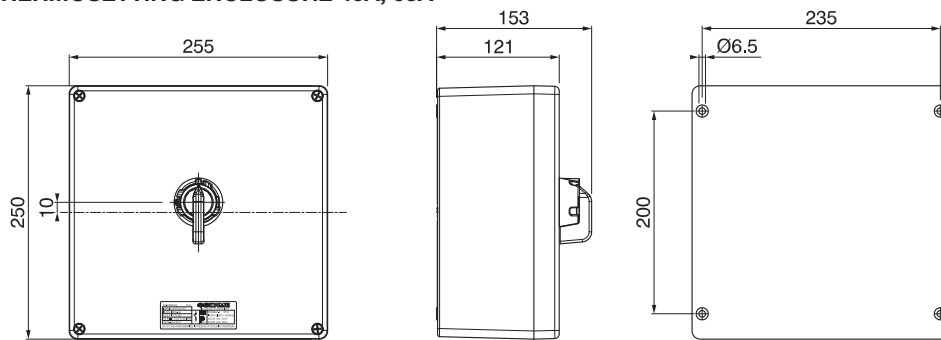

STAINLESS STEEL ENCLOSURE 20A, 25A, 32A

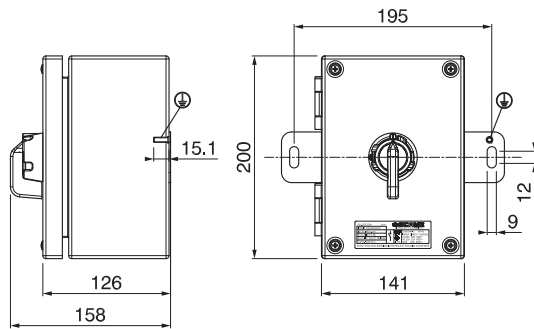

STAINLESS STEEL ENCLOSURE 40A, 63A

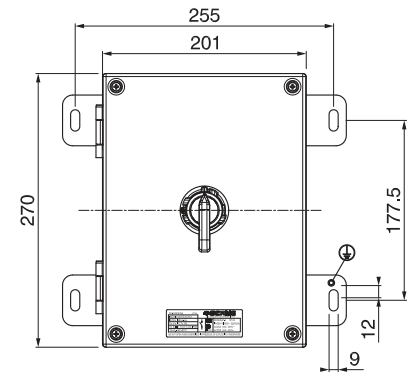

ALUMINIUM ENCLOSURE 20A, 25A, 32A, 40A, 63A

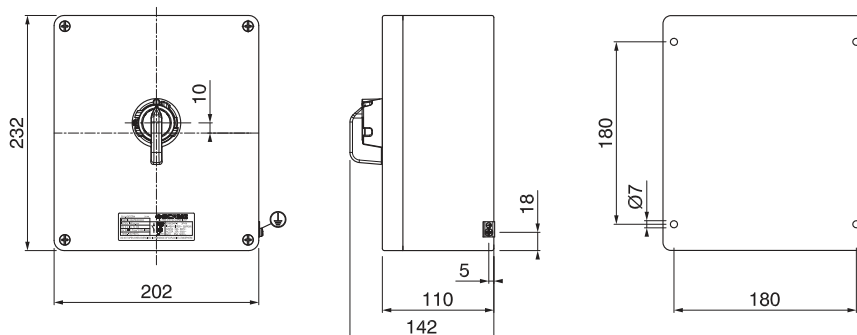

(Dimensions in mm)

DIMENSIONS

METALLIC CABLE GLANDS

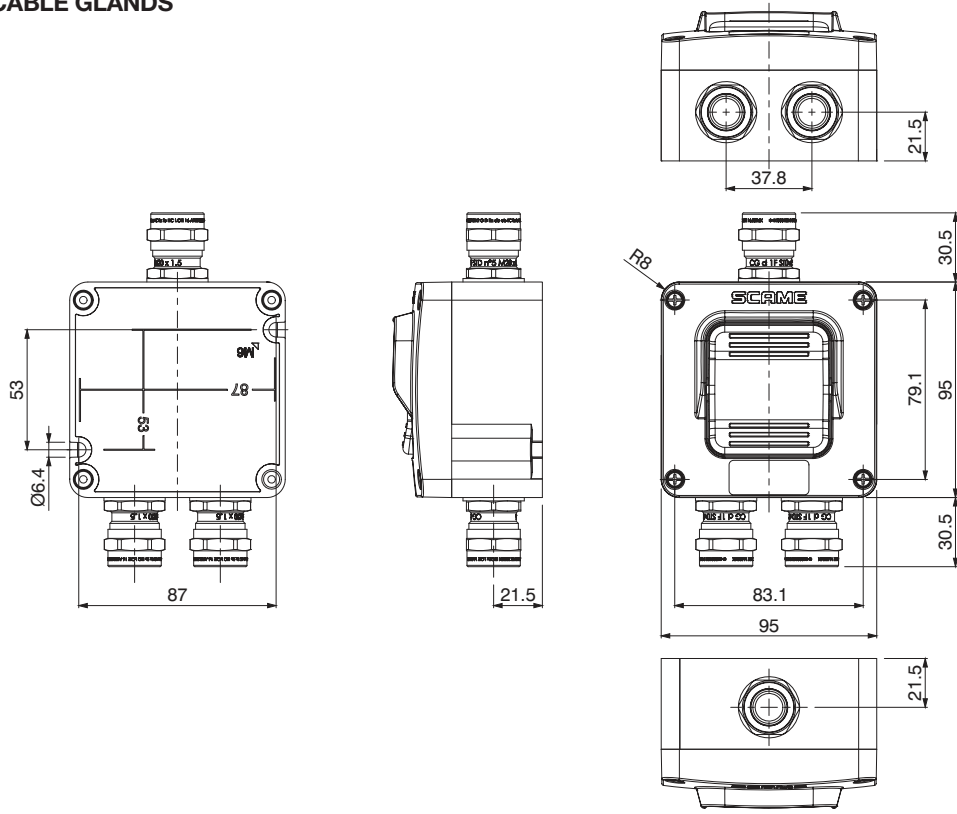

ARMoured METALLIC CABLE GLANDS

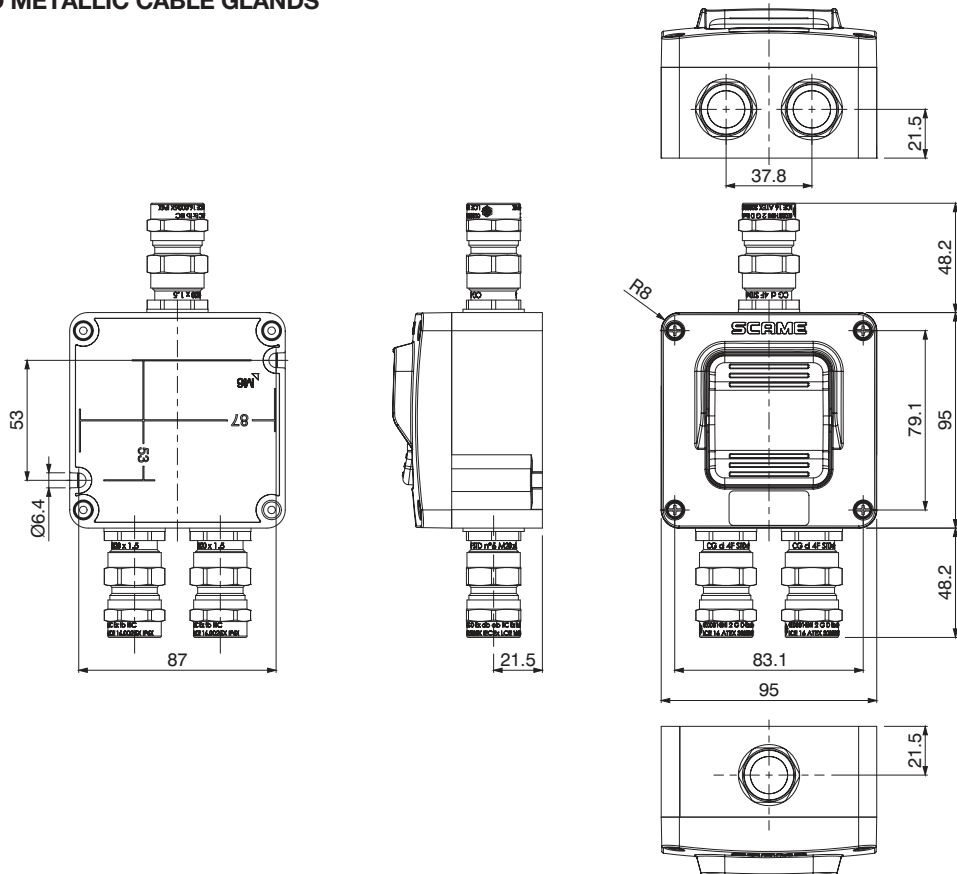

ROCKER-EX[GD] Series

 ATEX-IECEX-EAC Ex II 2GD

DIMENSIONS

PLASTIC CABLE GLANDS

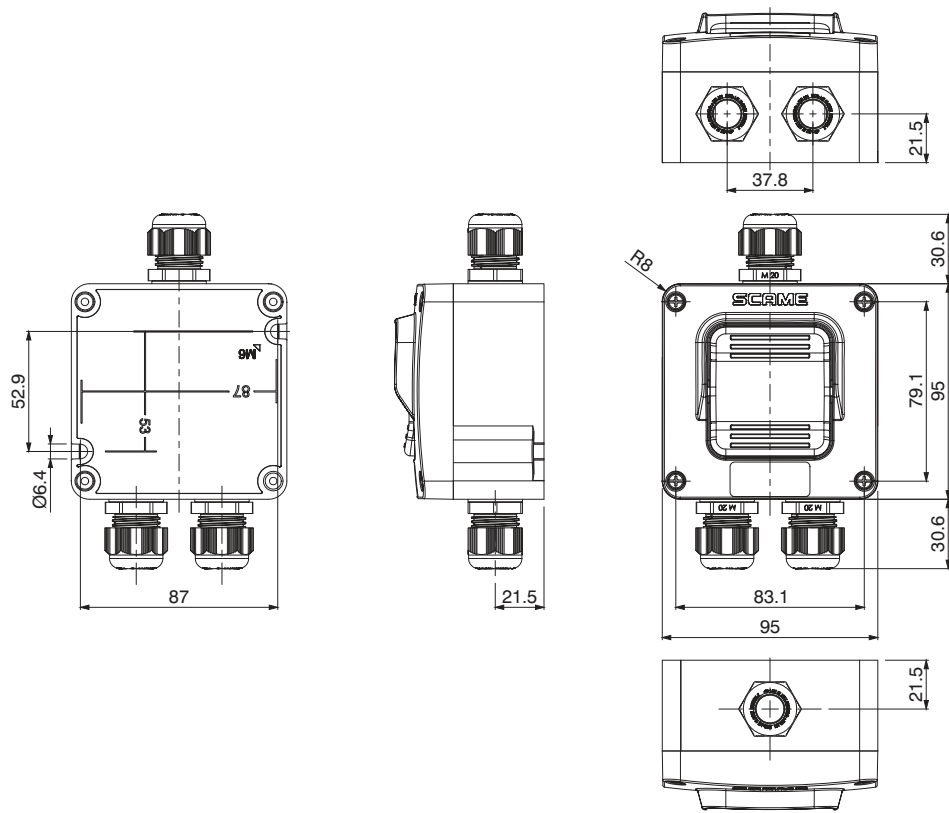

DIMENSIONS

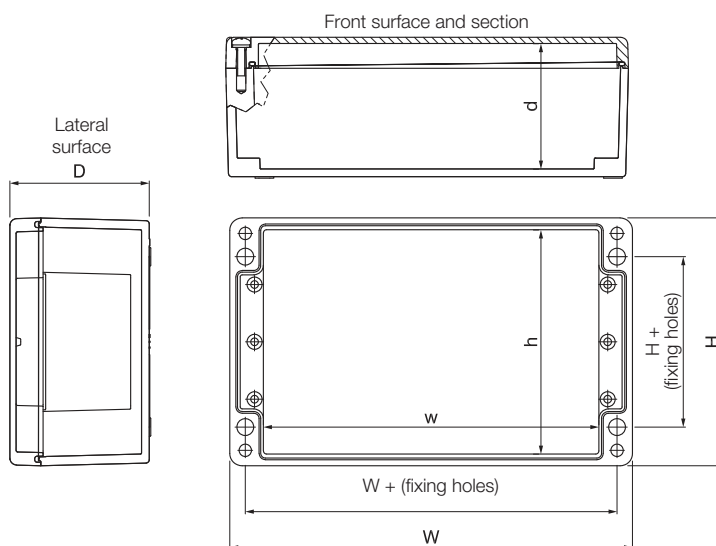

Dimensions	External			Internal			Fixings		Screws
	H	W	D	h	w	d	H+	W+	
75x80x55	75	80	55	58	48	46	45	68	M4
75x80x75	75	80	75	58	48	66	45	68	
75x110x55	75	110	55	58	78	46	45	98	
75x110x75	75	110	75	58	78	66	45	98	
75x160x55	75	160	55	58	128	46	45	148	
75x160x75	75	160	75	58	128	66	45	148	
75x190x55	75	190	55	58	158	46	45	178	
75x190x75	75	190	75	58	158	66	45	178	
75x230x55	75	230	55	58	198	46	45	218	
75x230x75	75	230	75	58	198	66	45	218	
120x122x90	120	122	90	102	104	80	82	106	M6
120x220x90	120	220	90	102	190	80	82	204	
160x160x90	160	160	90	142	112	80	110	140	
160x260x90	160	260	90	142	212	80	110	240	
160x360x90	160	360	90	142	312	80	110	340	
160x560x90	160	560	90	142	512	80	110	540	
250x255x120	250	255	120	230	235	110	200	235	
250x400x120	250	400	120	230	380	110	200	380	
405x400x165	405	400	165	385	380	154	355	380	

(Dimensions in mm)

ZENITH-S Series

ATEX-IECEX-EAC Ex II 2GD

DIMENSIONS

645.B

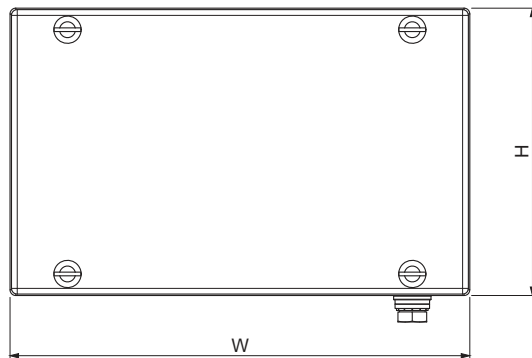
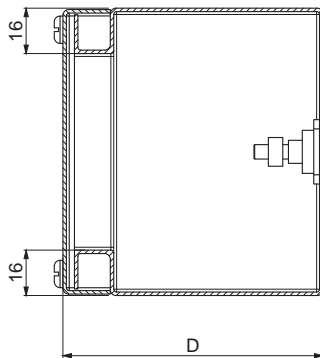
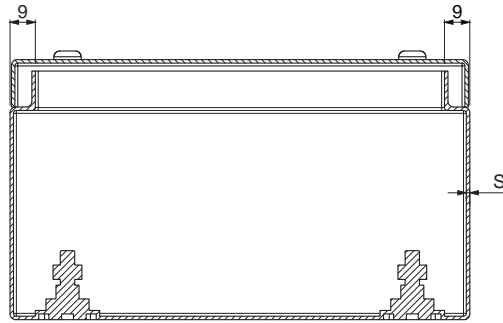
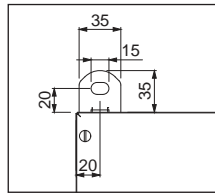
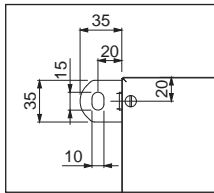

Dimensions	H	W	D	Body thickness (S)
90x90x75	90	90	75	1,2 mm
100x100x90	100	100	90	1,2 mm
100x160x90	100	160	90	1,2 mm
100x220x90	100	220	90	1,2 mm
150x160x120	150	160	120	1,2 mm
150x220x120	150	220	120	1,2 mm
150x280x120	150	280	120	1,2 mm
200x220x120	200	220	120	1,2 mm
200x280x120	200	280	120	1,2 mm
250x280x120	250	280	120	1,2 mm
250x340x150	250	340	150	1,2 mm
300x340x150	300	340	150	1,2 mm
300x400x150	300	400	150	1,2 mm
400x400x150	400	400	150	1,2 mm

(Dimensions in mm)

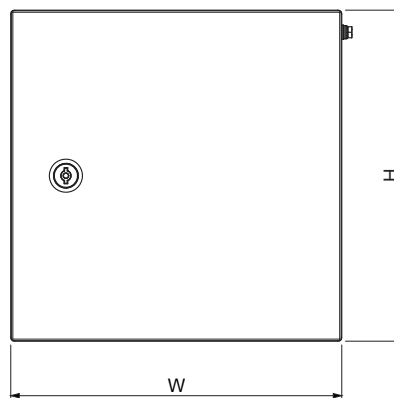
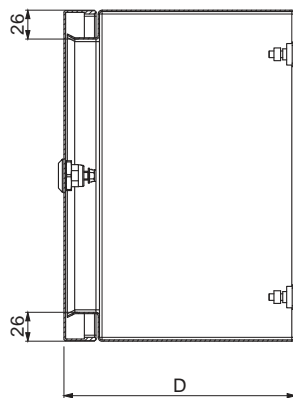
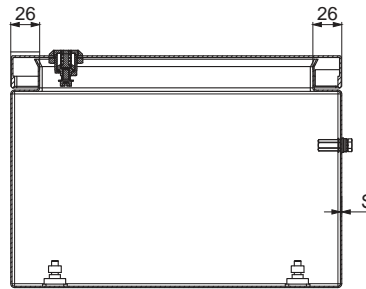
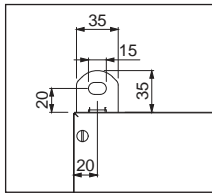
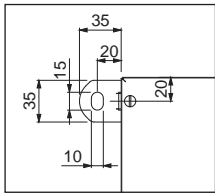
DIMENSIONS
645.C

Dimensions	H	W	D	Body thickness	Lid thickness	Key lock	Hinges
260x260x150	260	260	150	1,2 mm	1,5mm	1	2
300x300x210	300	300	210	1,2 mm	1,5mm	1	2
300x380x210	300	380	210	1,2 mm	1,5mm	1	2
300x450x210	300	450	210	1,2 mm	1,5mm	2	2
380x300x210	380	300	210	1,2 mm	1,5mm	1	2
380x380x210	380	380	210	1,2 mm	1,5mm	1	2
380x600x210	380	600	210	1,2 mm	1,5mm	2	2
400x500x210	400	500	210	1,2 mm	1,5mm	2	2
450x300x210	450	300	210	1,2 mm	1,5mm	1	2
450x450x210	450	450	210	1,2 mm	1,5mm	2	2
450x450x250	450	450	250	1,2 mm	1,5mm	2	2
450x600x210	450	600	210	1,2 mm	1,5mm	2	2
450x600x250	450	600	250	1,2 mm	1,5mm	2	2
500x700x250	500	700	250	1,2 mm	1,5mm	2	2
600x380x210	600	380	210	1,2 mm	1,5mm	1	2
600x450x250	600	450	250	1,2 mm	1,5mm	2	2
600x600x210	600	600	210	1,2 mm	1,5mm	2	2
600x600x250	600	600	250	1,2 mm	1,5mm	2	2
600x600x300	600	600	300	1,2 mm	1,5mm	2	2
600x750x210	600	750	210	1,5 mm	1,5mm	2	2
600x750x250	600	750	250	1,5 mm	1,5mm	2	2
600x750x300	600	750	300	1,5 mm	1,5mm	2	2
600x900x300	600	900	300	1,5 mm	1,5mm	2	3
750x1000x300	750	1000	300	1,5 mm	1,5mm	2	3
800x1200x300	800	1200	300	1,5 mm	2mm	2	3

(Dimensions in mm)

ZENITH-S Series

Ex ATEX-IECEX-EAC Ex
II 2GD

DIMENSIONS

645.D

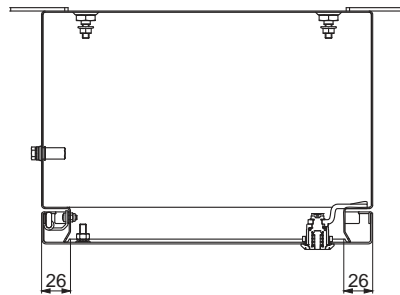
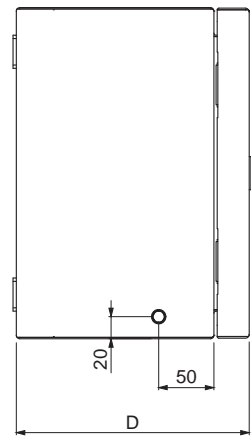
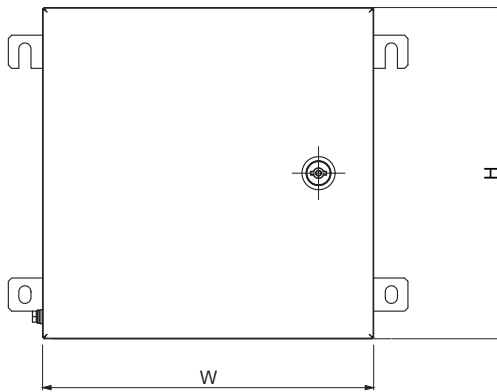
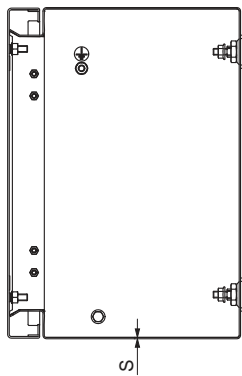
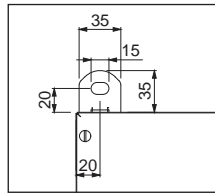
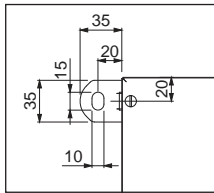

Dimensions	H	W	D	Body thickness	Mounting brackets
260x260x150	260	260	150	1,2 mm	4
300x300x210	300	300	210	1,2 mm	4
300x380x210	300	380	210	1,2 mm	4
300x450x210	300	450	210	1,2 mm	4
380x380x210	380	380	210	1,2 mm	4
400x500x210	400	500	210	1,2 mm	4
450x450x210	450	450	210	1,2 mm	4
450x600x210	450	600	210	1,2 mm	4
600x380x210	600	380	210	1,2 mm	4
600x600x210	600	600	210	1,2 mm	4
600x750x210	600	750	210	1,5 mm	4
600x900x300	600	900	300	1,5 mm	6
750x1000x300	750	1000	300	1,5 mm	6
800x1200x300	800	1200	300	1,5 mm	6

(Dimensions in mm)

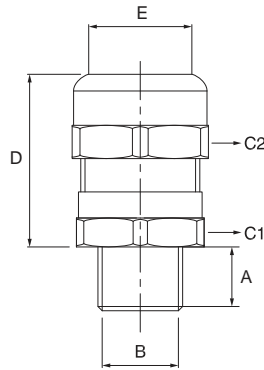
DIMENSIONS – METAL VERSIONS RN
**CABLE GLANDS
805.RN...**

Size	E	Ø A (mm)	Ø B (mm)	C1		C2		D	Weight (gr)
16 (EP-SI)	16	15	7 (M12) 11	24	26	24	26	38	94
20 (EP-SI)	20	15	15	30	33	32	35	40	156
25 (EP-SI)	25	15	19	35	38	36	39	40	185
32 (EP-SI)	32	15	25	42	47	45	49	52	340
40 (EP-SI)	38	15	35	48	53	50	55	52	421
50 (EP-SI)	44	15	44	55	60	57	62	52	537
63 (EP-SI)	54	15	57	68	74	67	72	52	749
75 (EP-SI)	65	15	68	80	86	80	88	52	1085
90 (EP-SI)	74	20	82	100	107	100	107	67	2125
91 (EP-SI)	80	20	82	100	107	100	107	67	1759

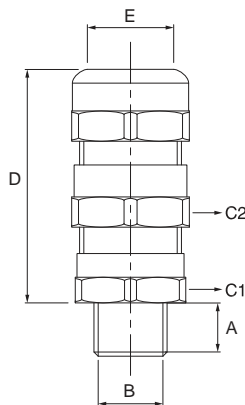
DIMENSIONS – METAL VERSIONS RAD
**CABLE GLANDS
805.RAD...**

Size	E	Ø A (mm)	Ø B (mm)	Armour range		C1		C2		D	Weight (gr)
				Standard cone	Reduced cone						
16 (EP-SI)	16	15	7 (M12) 11	0 ÷ 0,5	0,5 ÷ 0,75	24	26	24	26	58	126
20 (EP-SI)	20	15	15	0 ÷ 0,5	0,5 ÷ 1,25	32	33	32	35	64	228
25 (EP-SI)	25	15	19	0 ÷ 0,5	0,5 ÷ 1,25	36	38	36	39	64	264
32 (EP-SI)	32	15	25	0 ÷ 1	1 ÷ 1,6	45	47	45	49	83	484
40 (EP-SI)	38	15	35	0 ÷ 1	1 ÷ 1,6	50	53	50	55	83	576
50 (EP-SI)	44	15	44	0 ÷ 1	1 ÷ 2	57	60	57	62	83	730
63 (EP-SI)	54	15	57	0 ÷ 1	1 ÷ 2	67	74	67	72	83	961
75 (EP-SI)	65	15	68	0 ÷ 1	1 ÷ 2	80	86	80	88	83	1392
90 (EP-SI)	74	20	82	0 ÷ 2	2 ÷ 2,5	100	107	100	107	115	3026
91 (EP-SI)	80	20	82	0 ÷ 2	2 ÷ 2,5	100	107	100	107	115	2434

(Dimensions in mm)

UNION-EX Series

Ex ATEX-IECEX-EAC Ex II 2GD

DIMENSIONS – METAL VERSIONS RAD

SCREW PLUGS 805.RT...

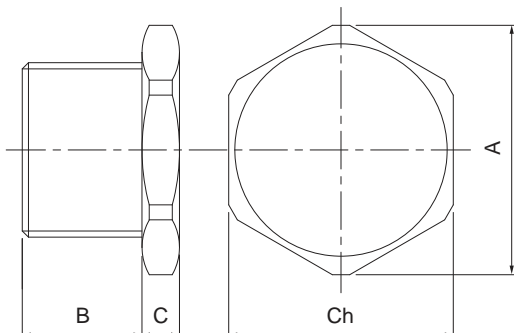

Thread	Ch	A	B	C
M12x1.5	16	17,6	15	5
M16x1.5	20	22	15	5
M20x1.5	24	26,4	15	5
M25x1.5	30	33	15	5
M32x1.5	36	39,6	15	5
M40x1.5	45	49,5	15	5
M50x1.5	55	60	15	5
M63x1.5	68	74	15	8
M75x1.5	80	86	20	8
M90x2	100	107	20	8

LOCKNUTS 805.RL...

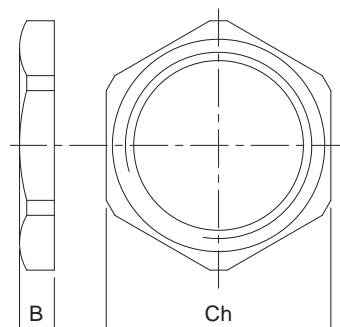

Thread	Ch	B
M12x1.5	15	2,8
M16x1.5	19	2,8
M20x1.5	24	3
M25x1.5	30	3,5
M32x1.5	36	4
M40x1.5	46	4,5
M50x1.5	60	5
M63x1.5	70	5,5
M75x1.5	83	10
M90x2	102	10

EARTHING TAGS 805.RE...

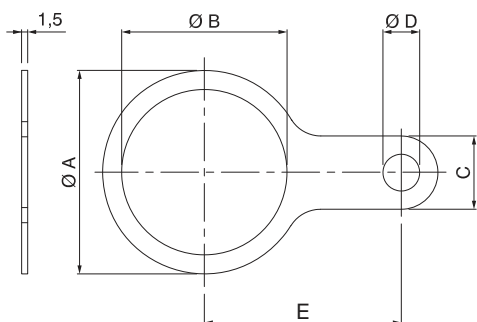

Type	Dimensions				
	ØA	ØB	C	ØD	E
M12	30	14	12	6,5	30
M16	30	18	12	6,5	30
M20	30	22	12	6,5	30
M25	36	28	15	6,5	35
M32	52	34	18	9	50
M40	52	42	18	9	50
M50	62	52	22	11	60
M63	75	65	22	11	70
M75	88	77	22	11	80
M90	105	92	30	14	100

SEALS 805.RG...

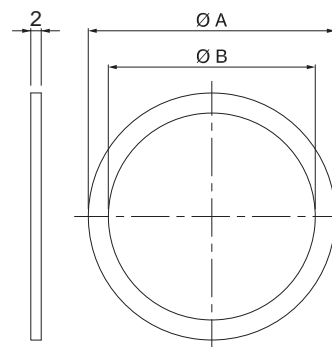

Type	Dimensions		
	ØA	ØB (Nylon)	ØB (Silicone)
M12	20	12,5	12
M16	25	16,5	16
M20	30	20,5	20
M25	35	25,5	25
M32	42	32,5	32
M40	50	40,5	40
M50	60	50,5	50
M63	76,5	63,5	63
M75	85	75,5	75
M90	104	90,5	90

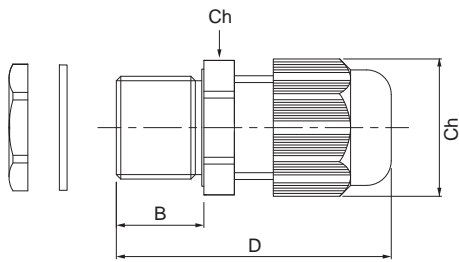
DIMENSIONS – POLYAMIDE VERSIONS
**CABLE GLANDS
805.EX54/55...**

Thread	Cable inlets	Short			Long		
		B	Ch	D	B	Ch	D
M12x1.5	4.5 - 6.5	8	15	32	15	15	39
	5.0 - 8.0	10	19	37	15	19	42
M16x1.5	5.0 - 10.0	10	22	39	15	22	44
	7.0 - 12.0	10	24	40	15	24	45
M20x1.5	10.0 - 14.0	10	27	43	15	27	48
	10.0 - 14.0	10	27	45	15	27	50
M25x1.5	12.0 - 18.0	10	33	49	15	33	53
	16.0 - 25.0	10	42	52	15	42	57
M32x1.5	22.0 - 32.0	10	53	62	16	53	68
M40x1.5	28.0 - 38.5	12	60	67	16	60	71
M63x1.5	40.0 - 48.0	12	70	68	16	70	72
M12x1.5	3.0 - 5.0	8	15	32	15	15	39
	4.0 - 6.0	10	19	37	15	19	42
M16x1.5	4.0 - 7.0	10	22	39	15	22	44
	5.0 - 9.0	10	24	40	15	24	45
M20x1.5	8.0 - 12.0	10	27	43	15	27	48
	8.0 - 12.0	10	27	45	15	27	50
M25x1.5	10.0 - 16.0	10	33	49	15	33	53
	14.0 - 21.0	10	42	52	15	42	57
M32x1.5	16.0 - 26.0	10	53	62	16	53	68
M40x1.5	20.0 - 31.0	12	60	67	16	60	71
M63x1.5	30.0 - 39.0	12	70	68	16	70	72

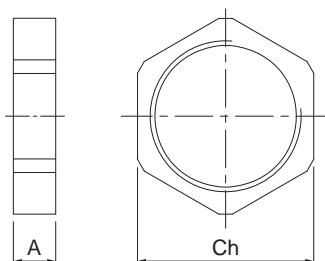
**LOCKNUTS
805.EX57...**

Thread	Ch	A
M12x1.5	17	5
M16x1.5	22	5
M20x1.5	24	5
M25x1.5	30	6
M32x1.5	38	7,5
M40x1.5	50	8
M50x1.5	60	9
M63x1.5	75	10

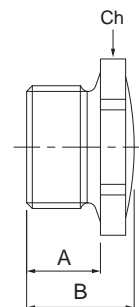
**SCREW PLUGS
805.EX58...**

Thread	Ch	A	B
M12x1.5	16	8	11
M16x1.5	20	8	12
M20x1.5	26	9	13
M25x1.5	32	10	15
M32x1.5	40	11	16,5
M40x1.5	48	12	18
M50x1.5	55	13	21
M63x1.5	70	15	24,5

DIMENSIONS – POLYAMIDE VERSIONS

REDUCER 805.EX50...

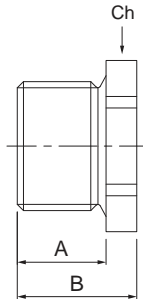

Male thread	Female thread	Ch	A	B
M16x1.5	M12x1.5	20	8	11
M20x1.5	M16x1.5	24	9	12
M25x1.5	M20x1.5	30	10	13,5
M32x1.5	M25x1.5	36	11	15
M40x1.5	M32x1.5	44	12	16
M50x1.5	M40x1.5	55	13	18
M63x1.5	M50x1.5	70	15	21

ENLARGER 805.EX51...

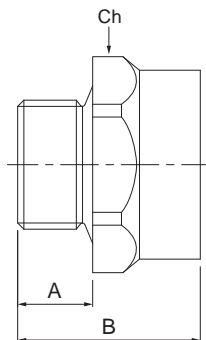

Male thread	Female thread	Ch	A	B
M12x1.5	M16x1.5	20	8	19
M16x1.5	M20x1.5	24	8	20
M20x1.5	M25x1.5	30	9	22
M25x1.5	M32x1.5	36	10	24
M32x1.5	M40x1.5	44	11	26
M40x1.5	M50x1.5	55	12	28
M50x1.5	M63x1.5	70	13	32

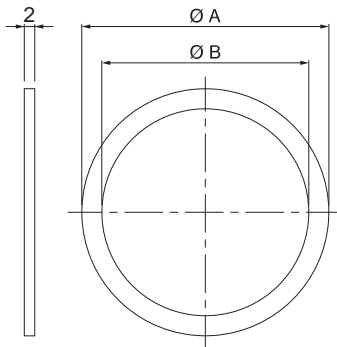
SEALS
805.EX59...

Type	ØA	ØB
M12	15	10
M16	20	13,9
M20	24	18
M25	30	23
M32	40	30
M40	48	38
M50	58	48
M63	75	61
M75	90	72

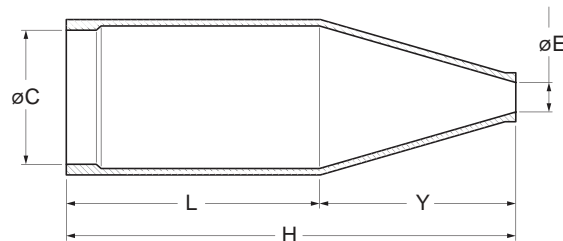
CABLE GLAND SHROUD PROTECTION

Code	Dimensions	ØC	ØE	L	Y	H
805.RS16	16	25	6	46	38	84
805.RS20	20	34	8	58	45	103
805.RS25	25	38	12	58	45	103
805.RS32	32	48	18	71	38	109
805.RS40	40	53	25	71	38	109
805.RS50	50	61	30	71	42	113
805.RS63	63	72	40	71	42	113
805.RS75.EP	75	83	52	76	42	118
805.RS90.EP	90a/b	104	66	93	59	152

2

ATEX [II 2D]

- Zone 21 (Db)
- Zone 22 (Dc)

DUST

■ ADVANCE-GRP[EX] Series



page 112

■ OPTIMA-EX Series



page 116

■ ISOLATORS-EX Series



page 120

ADVANCE-GRP[EX] Series



SWITCHED INTERLOCKED SOCKET OUTLETS



The sockets with mechanical interlock in the ADVANCE-GRP[EX] Series are suitable for installation in environments with classification Ex zone 21/Db - 22/Dc (due to the presence of the combustible dust in group IIIC). The use of a GRP material (Glass-fibre Reinforced Polyester) combined with the substantial thickness of the enclosure walls guarantees excellent mechanical resistance and a long life. This material is highly resistant to contamination and corrosion and is suitable for applications requiring the use of components with a low smoke emission and no halogens (LSOH Low Smoke Zero Halogen). It is possible to install auxiliary contacts, to be purchased separately, without losing the certification. Sockets in the ADVANCE-GRP[EX] Series can be used with plugs in the OPTIMA-EX Series.

VERSIONS WITH MECHANICAL INTERLOCK

	With switch-disconnector
	With switch-disconnector and fuse

TECHNICAL CHARACTERISTICS

Rated current:	16A-32A-63A
Rated voltage:	100÷690V~
Frequency:	50÷60Hz
Insulating voltage:	500/690V~
Self-extinguishing GW test:	960°C
Fuse:	
16A-32A	gG 10,3x38mm
63A	gG 22x58mm
Protection degree:	IP66
Impact Resistance:	7J
Colour:	Grey RAL 7037

REFERENCE STANDARDS

ATEX	EN 60079-0 Electrical apparatus for potentially explosive atmospheres. <i>Part 0: General requirements.</i>
ATEX	EN 60079-31 Electrical apparatus for potentially explosive atmospheres. <i>Part 31: Protection by enclosures "t".</i>
LVD	EN 60309-1 Plugs, socket outlets and couplers for industrial purposes. <i>Part 1: general requirements.</i>
LVD	EN 60309-2 Plugs, socket outlets and couplers for industrial purposes. <i>Part 2: dimensional interchangeability requirements for pin and contact-tube accessories of harmonised configurations.</i>
LVD	EN 60309-4 Plugs, socket-outlets and couplers for industrial purposes. <i>Part 4: Switched socket-outlets and connectors with or without interlock.</i>

Ex CHARACTERISTICS

ATEX Category:	II 2D
Ex Protection type:	Ex tb IIIC T90°C Db -25°C ≤ Ta ≤ +60°C
Surface temperature class DUST:	T90°C
CE Certificate 16A-32A-63A:	IMQ 11 ATEX 010

BEHAVIOUR WITH CHEMICAL AND ATMOSPHERIC AGENTS

Saline solution	Acids		Bases		Solvents				Mineral oil	UV rays
	Concentrated	Diluted	Concentrated	Diluted	Hexane	Benzol	Acetone	Alcohol		
Resistant	Limited Resistance	Resistant	Limited Resistance	Resistant	Resistant	Resistant	Resistant	Resistant	Resistant	Resistant

Resistance values to chemical agents have to be considered indicative.

For further information and specific substances, contact the technical service.

CABLE ENTRY

Maximum entry with cable glands

Rated current (A)	Single socket	
	Upper	Lower
16A-32A	M32	M32
63A	KIT 579.EX0201 (*)	-

(*) Cable entry in the 63A version must be done through the relevant junction box equipped with a single cable entry type M50x1.5 (Junction box Kit art. 579.EX0201).

Cable gland available on request.

WIRING OPERATIONS

Wiring capacity of the terminals (mm²)

Rated current (A)	Socket outlets
	Min
16A	4
32A	10
63A	25

ELECTRICAL PARAMETERS - AUXILIARY CONTACT

ELECTRICAL PARAMETERS AUXILIARY CONTACT SERIES 590.PL00400X		
Auxiliary contacts	Maximun Current	Note
1NC or 1NO	Max 2A	With 1 Auxiliary contacts the maximum current is 2A
1NC or 1NO	Max 2A	
2NC or 2NO	Max 1A	With 2 Auxiliary contacts the maximum current is 1A each
2NC or 2NO	Max 1A	

See auxiliary contact table page. 115

ADVANCE-GRP[EX] Series



■ TECHNICAL FEATURES, CROSS SECTIONAL AREA AND TORQUE

Rated Current			16A	32A	63A
Switch-command and/or fuse protection		Catalogue number	Terminals - Torque (Nm)		
Switch type serie Command (SCAME)		503.16... 503.32... 503.63...	0,8	0,8	3,6
Switch-Command & fuse 16-32A : 10:3 38 gG 63A : CH 22 X 58 63A gG		503.16...F 503.32...F 503.63...F	0,8	0,8	3,6
Earth terminals		503.16... 503.32... 503.63...	1,2	1,2	3,5

CABLE ENTRY

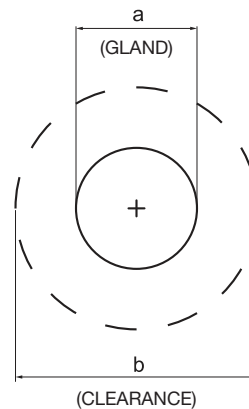
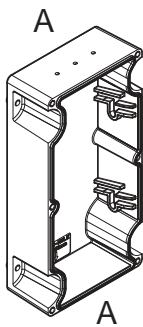

16A/32A WxD (mm ²)	63A WxD (mm ²)	Type cable entry M	GLAND a (mm)	CLEARANCE b (mm)	Area A n°
80x45	110x55	16A 32A	33 37,5	50 50	2 2

NOTE:

For Ex cable glands installations refer to the instructions by manufacturer.

Cable entry for 63A socket have to be done with the only one cable entry type M50x1,5 (kit type, art. 579.EX0201).

■ CROSS SECTIONAL AREAS AND CABLE TEMPERATURE

FINELY-STRANDED 16A: 4mm² - 32A: 10mm² - 63A: 25mm²

SINGLE-WIRE 16A: 4mm² - 32A: 10mm² - 63A: 25mm²

Rated current	Max. current			Optima-EX ΔT cable
	T. amb 40°C	T. amb 50°C	T. amb 60°C	
16A	-	-	16A	-
32A	-	-	25A	-
63A	55A	50A	45A	85°C

SWITCHED INTERLOCKED SOCKET OUTLETS - IP66

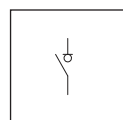

Description	Socket	Hz	Volt	Colour	h.	16A	32A	63A
						Ⓜ 1	Ⓜ 1	Ⓜ 1
Switch-disconnector	2P+E	50/60	200-250V		6	503.1683	503.3283	503.6383
	2P+E	50/60	100-130V		4	503.1670	-	-
	3P+E	50/60	380-415V		6	503.1686	503.3286	503.6386
	3P+N+E	50/60	346-415V		6	503.1687	503.3287	503.6387

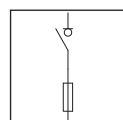

Description	Socket	Hz	Volt	Colour	h.	16A	32A	63A
						Ⓜ 1	Ⓜ 1	Ⓜ 1
Switch-disconnector and fuse (*)	2P+E	50/60	200-250V		6	503.1683-F	503.3283-F	503.6383-F
	3P+E	50/60	380-415V		6	503.1686-F	503.3286-F	503.6386-F
	3P+N+E	50/60	346-415V		6	503.1687-F	503.3287-F	503.6387-F

Ⓜ Package/Bulk Pack
 (*) Fuses not included.

ACCESSORIES AND COMPLEMENTARY PRODUCTS



Description	Ⓜ	
Junction box Kit (63A) M50-EX (*)	1/12	579.EX0201

(*) Only for the 63A version. Cable gland M50 available upon request.

AUXILIARY CONTACTS



Description	For switches	Ⓜ	
NC contact	16A-32A	10	590.PL004001
	63A	10	590.PL004003
NO contact	16A-32A	10	590.PL004002
	63A	10	590.PL004004

NC= normally closed.
 NO= normally open.

Maximum current : see table page 113.
 Ⓜ Package/Bulk Pack

OPTIMA-EX Series



PLUGS



Plugs in the OPTIMA-EX Series are suitable for use in environments with classification Ex zone 21/Db - 22/Dc (due to the presence of the combustible dust in group IIIC).

They are compatible with the interlocked sockets in the ADVANCE-GRP[EX] Series, but can be connected, when in a “safe zone”, to any socket compliant with the industrial standard IEC/EN 60309 having the same polarity.

VERSIONS



Plugs

TECHNICAL CHARACTERISTICS

Rated current:	16A-32A-63A
Rated voltage:	100÷690V~
Frequency:	50÷60Hz
Insulating voltage:	500/690V~
Self-extinguishing GW test:	960°C
Protection degree:	IP66
Impact Resistance:	7J
Plugs material:	Thermoplastic
Plugs colour:	Black RAL9011

REFERENCE STANDARDS

ATEX	EN 60079-0 Electrical apparatus for potentially explosive atmospheres. <i>Part 0: General requirements.</i>
ATEX	EN 60079-31 Electrical apparatus for potentially explosive atmospheres. <i>Part 31: Protection by enclosures “t”.</i>
LVD	EN 60309-1 Plugs, socket outlets and couplers for industrial purposes. <i>Part 1: general requirements.</i>
LVD	EN 60309-2 Plugs, socket outlets and couplers for industrial purposes. <i>Part 2: dimensional interchangeability requirements for pin and contact-tube accessories of harmonised configurations.</i>

Ex CHARACTERISTICS

ATEX Category:	Ex II 2D
Ex Protection type:	Ex tb IIIC Db -25°C ≤Ta ≤+60°C
Surface temperature class DUST:	T90°C
CE Certificate 16A-32A-63A:	IMQ 11 ATEX 011

BEHAVIOUR WITH CHEMICAL AND ATMOSPHERIC AGENTS

Saline solution	Acids		Bases		Solvents				Mineral oil	UV rays
	Concentrated	Diluted	Concentrated	Diluted	Hexane	Benzol	Acetone	Alcohol		
Resistant	Limited Resistance	Resistant	Limited Resistance	Resistant	Resistant	Resistant	Resistant	Resistant	Resistant	Resistant

Resistance values to chemical agents have to be considered indicative.

For further information and specific substances, contact the technical service.

WIRING OPERATIONS

Wiring capacity of the terminals (mm²)

Rated current (A)	Plugs	
	Min	Max
16A	2,5	2,5
32A	6	6
63A	16	16

APPLICATION EXAMPLES



OPTIMA-EX Series



TECHNICAL CHARACTERISTICS

OPTIMA-EX Series	Unit	Rated Current			
Rated Current		16A	32A	63A	
Code		218.16...-EX	218.32...-EX	218.63...-EX	
Suitable Size cables Ground-Terminals	(mm ²)	2.5	6	16	
Power Supply Terminals - Tightening-Torque	(Nm)	0.8	0.8	2.2	
Cable size accepted by Cable-Clamp (eg.H07RN-F)	(mm)	2P+E	10.9-14	14.1-18	22-34
		3P+E	12.1-15.5	15.7-20	22-34
		3P+N+E	13.3-17	17.5-22.5	22-34
Cable Gland/Cable-Clamp Tightening-Torque	(Nm)	2P+E	5.6	5.6	13
		3P+E	5.6	5.6	13
		3P+N+E	5.6	9	13
Cable-Gland/Cable-Clamp (Screw) - Tightening-Torque	(Nm)	-	-	0.8	
Handle Screws – Tightening-Torque	(Nm)	-	-	0.9	

Rated Current	Max rated current			Cable size ADVANCE-GRP[EX]	ΔT cable entry	ΔT cable
	T. amb 40°C	T. amb 50°C	T. amb 60°C			
16A	-	-	16A	4 mm ² Stranded-cable	20,3 K	-
32A	-	-	25A	10 mm ² Stranded-cable	21,1 K	-
63A	55A	50A	45A	25 mm ² Stranded-cable	20,4 K	85°C

PLUGS - IP66



Description	Poles	Hz	Volt	Colour	h.	16A	32A	63A
						⊞ 1	⊞ 1	⊞ 1
Plug	2P+E	50/60	200-250V	█	6	218.EX1633	218.EX3233	218.EX6333
	2P+E	50/60	100-130V	█	4	218.EX1630	-	-
	3P+E	50/60	380-415V	█	6	218.EX1636	218.EX3236	218.EX6336
	3P+N+E	50/60	346-415V	█	6	218.EX1637	218.EX3237	218.EX6337

⊞ Package/Bulk Pack

ISOLATORS-EX Series



SWITCHES DISCONNECTORS



ISOLATORS-EX is a range of load-break switches/disconnectors with a switching and isolating functions, built in accordance with the standard EN 60947-3. Able to satisfy all installation needs, they are available in two versions in terms of the material used for the enclosure: thermoplastic or aluminium. They have a category of use up to AC-3 and are available in different versions for general use (handle in black) or for emergency control (high-visibility handle in red/yellow). It is possible to install auxiliary contacts, to be purchased separately, without losing the certification.

VERSIONS



Switch disconnector
Aluminium enclosure



Switch disconnector
Thermoplastic enclosure

TECHNICAL CHARACTERISTICS

Protection degree:	IP65 (aluminium) IP66 (thermoplastic)
Ambient temperature:	-25°C ≤ Ta ≤ +60°C
Glow wire test:	650°C (thermoplastic)
Material:	Aluminium Thermoplastic
Colour:	Satin-finished (aluminium) Grey RAL 7016 (thermoplastic)
Polarity:	2P - 3P - 4P
Rated current:	20A-32A-40A-63A (aluminium) 20A-32A-40A (thermoplastic)

REFERENCE STANDARDS

ATEX	EN 60079-0 Electrical apparatus for potentially explosive atmospheres. <i>Part 0: General requirements.</i>
ATEX	EN 60079-31 Electrical apparatus for potentially explosive atmospheres. <i>Part 31: Protection by enclosures "t".</i>
LVD	EN 60309-1 Plugs, socket outlets and couplers for industrial purposes. <i>Part 1: general requirements.</i>
LVD	EN 60947-3 Low-voltage switchgear and controlgear. <i>Part 3: Switches, disconnectors, switch-disconnectors and fuse-combination units.</i>

Ex CHARACTERISTICS

ATEX Category:	Ex II 2D
Ex Protection type	
Thermoplastic:	Ex tb IIIC T80°C Db (-25°C ≤ Ta ≤ +40°C) Ex tb IIIC T90°C Db (-25°C ≤ Ta ≤ +60°C)
Aluminium:	Ex tb IIIC T80°C Db (-25°C ≤ Ta ≤ +40°C) Ex tb IIIC T90°C Db (-25°C ≤ Ta ≤ +60°C)
Surface temperature class DUST:	T90°C
Certificate:	TÜV IT 14 ATEX 006 (aluminium) TÜV IT 14 ATEX 005 (thermoplastic)

BEHAVIOUR WITH CHEMICAL AND ATMOSPHERIC AGENTS - ALUMINIUM

Saline solution	Acids		Bases		Solvents				Mineral oil	UV rays
	Concentrated	Diluted	Concentrated	Diluted	Hexane	Benzol	Acetone	Alcohol		
Resistant	Limited Resistance	Resistant	Resistant	Resistant	Not Resistant	Not Resistant	Not Resistant	Limited Resistance	Resistant	Resistant

BEHAVIOUR WITH CHEMICAL AND ATMOSPHERIC AGENTS - THERMOPLASTIC

Saline solution	Acids		Bases		Solvents				Mineral oil	UV rays
	Concentrated	Diluted	Concentrated	Diluted	Hexane	Benzol	Acetone	Alcohol		
Resistant	Limited Resistance	Resistant	Limited Resistance	Limited Resistance	Resistant	Limited Resistance	Limited Resistance	Resistant	Limited Resistance	Resistant

Resistance values to chemical agents have to be considered indicative.
For further information and specific substances, contact the technical service.

APPLICATION EXAMPLES

ISOLATORS-EX Series

Ex II 2D aluminium enclosure

ELECTRICAL CHARACTERISTICS OF THE SWITCH DISCONNECTORS

Rated current Ith		20A	32A	40A	63A
Insulating voltage Ui	VAC	690	690	690	690
AC22A Mixed resistive and inductive loads, including moderate overloads	415V	20A	32A	40A	63A
	690V	20A	32A	32A	63A
AC23A Rated operational power (°)	415V	20A	32A	35A	63A
	690V	20A	25A	25A	30A
AC3 Squirrel-cage motor: starting, switching off motor during running (3 phase / 3 pole)	400V	18A	25A	28,5A	40A
	690V	12A	18A	20A	25A
Nominal frequency	Hz	50/60Hz	50/60Hz	50/60Hz	50/60Hz

(°) This values are given for guidance and may vary according to the specifics provided by the motor manufacturer.

TECHNICAL DATA OF POWER / EARTH TERMINALS

POWER TERMINALS - CONNECTABLE WIRES AND TIGHTENING TORQUES		
Power terminal version	Cable section to be used (rigid or flexible) mm ²	Tightening torque (Nm)
20A	4	0.8
32A	6	0.8
40A	6	0.8
63A	10	3.6
Earth terminal	Maximum section 10	2

CABLE GLANDS / CABLE ENTRIES

Versions	Number of cable entries	Maximum cable inlet temperature
590.XHGE200X – 20A	2xM25 + 1XM20 (high)	-
590.XHEM200X – 20A		
590.XHGE320X – 32A	2xM25 + 1XM20 (high)	95° C
590.XHEM320X – 32A		
590.XHGE400X – 40A		
590.XHEM400X – 40A		
590.XHGE630X - 63A	2xM32 + 1XM20 (high)	110° C
590.XHEM630X - 63A		

ELECTRICAL PARAMETERS - AUXILIARY CONTACT

ELECTRICAL PARAMETERS AUXILIARY CONTACT SERIES 590.PL00400X		
Auxiliary contacts	Maximum Current	Note
1NC or 1NO	Max 2A	With 1 Auxiliary contacts the maximum current is 2A
1NC or 1NO	Max 2A	
2NC or 2NO	Max 1A	With 2 Auxiliary contacts the maximum current is 1A each
2NC or 2NO	Max 1A	

ELECTRICAL CHARACTERISTICS OF THE SWITCH DISCONNECTORS

Rated current Ith		20A	32A	40A
Insulating voltage Ui	VAC	690	690	690
AC22A Mixed resistive and inductive loads, including moderate overloads	415V	20A	32A	40A
	690V	20A	32A	32A
AC23A Rated operational power (°)	415V	20A	32A	35A
	690V	20A	25A	25A
AC3 Squirrel-cage motor: starting, switching off motor during running (3 phase / 3 pole)	400V	18A	25A	28,5A
	690V	12A	18A	20A
Nominal frequency	Hz	50/60	50/60	50/60

(°) This values are given for guidance and may vary according to the specifics provided by the motor manufacturer.

TECHNICAL DATA OF POWER / EARTH TERMINALS

POWER TERMINALS - CONNECTABLE WIRES AND TIGHTENING TORQUES		
Power terminal version	Cable section to be used (rigid or flexible) mm ²	Tightening torque (Nm)
20A	4	0.8
32A	6	0.8
40A	10	0.8
Earth terminal	Maximum section 10	2

CABLE GLANDS / CABLE ENTRIES

Versions	Number of cable entries	Maximum cable inlet temperature
590.XGE200X - 20A	2xM25 + 1xM20	-
590.XEM200X - 20A		
590.XGE320X - 32A	2xM32 + 1xM20	95° C
590.XEM320X - 32A		
590.XGE400X - 40A		
590.XEM400X - 40A		

The safety switch hereby in the following table will be equipped with cable glands and stopping plug suitable for use in areas at risk of explosion, suitable for the category 2D, zone 21 and 22.

LOCKING TORQUES

Threaded hole	Maximum tightening torque (Nm)
M20	10
M25	12
M32	14

ELECTRICAL PARAMETERS - AUXILIARY CONTACT

ELECTRICAL PARAMETERS AUXILIARY CONTACT SERIES 590.PL00400X		
Auxiliary contacts	Maximun Current	Note
1NC or 1NO	Max 2A	With 1 Auxiliary contacts the maximum current is 2A
1NC or 1NO	Max 2A	
2NC or 2NO	Max 1A	With 2 Auxiliary contacts the maximum current is 1A each
2NC or 2NO	Max 1A	

ISOLATORS-EX Series



ALUMINIUM SWITCHES DISCONNECTORS - IP65



Current	Poles	Cable inlets	Dimensions (mm)	☐	GENERAL USE	
					■	■
					EMERGENCY CONTROL	■
20A	2	2xM25 + 1xM20 (high)	105x150x82	1/12	590.XHGE2002	590.XHEM2002
	3		105x150x82	1/12	590.XHGE2003	590.XHEM2003
	4		105x150x82	1/12	590.XHGE2004	590.XHEM2004
32A	2	2xM25 + 1xM20 (high)	105x150x82	1/12	590.XHGE3202	590.XHEM3202
	3		105x150x82	1/12	590.XHGE3203	590.XHEM3203
	4		105x150x82	1/12	590.XHGE3204	590.XHEM3204
40A	2	2xM25 1xM20 (high)	105x150x82	1/12	590.XHGE4002	590.XHEM4002
	3		105x150x82	1/12	590.XHGE4003	590.XHEM4003
	4		105x150x82	1/12	590.XHGE4004	590.XHEM4004
63A	2	2xM32 + 1xM20 (high)	150x210x107	1/5	590.XHGE6302	590.XHEM6302
	3		150x210x107	1/5	590.XHGE6303	590.XHEM6303
	4		150x210x107	1/5	590.XHGE6304	590.XHEM6304

- 1xM20 (top): on request
☐ Package/Bulk Pack.

THERMOPLASTIC SWITCHES DISCONNECTORS - IP66



Current	Poles	Cable inlets	Dimensions (mm)	☐	GENERAL USE	
					■	■
					EMERGENCY CONTROL	■
20A	2	2xM25 + 1xM20	115x190x128	1/12	590.XGE2002	590.XEM2002
	3		115x190x128	1/12	590.XGE2003	590.XEM2003
	4		115x190x128	1/12	590.XGE2004	590.XEM2004
32A	2	2xM32 + 1xM20	115x190x128	1/12	590.XGE3202	590.XEM3202
	3		115x190x128	1/12	590.XGE3203	590.XEM3203
	4		115x190x128	1/12	590.XGE3204	590.XEM3204
40A	2	2xM32 + 1xM20	115x190x128	1/12	590.XGE4002	590.XEM4002
	3		115x190x128	1/12	590.XGE4003	590.XEM4003
	4		115x190x128	1/12	590.XGE4004	590.XEM4004

☐ Package/Bulk Pack.

- Auxiliary contacts:
NC 16A-32A: 590.PL004001
NC 63A: 590.PL004003

NO 16A-32A: 590.PL004002
NO 63A: 590.PL004004

See table page 115.

Padlockable handle in two positions (ON/OFF).
OFF position = 3 padlocks
ON position = 1 padlock

2

ATEX [II 2D]

- Zone 21 (Db)
- Zone 22 (Dc)

DIMENSIONS

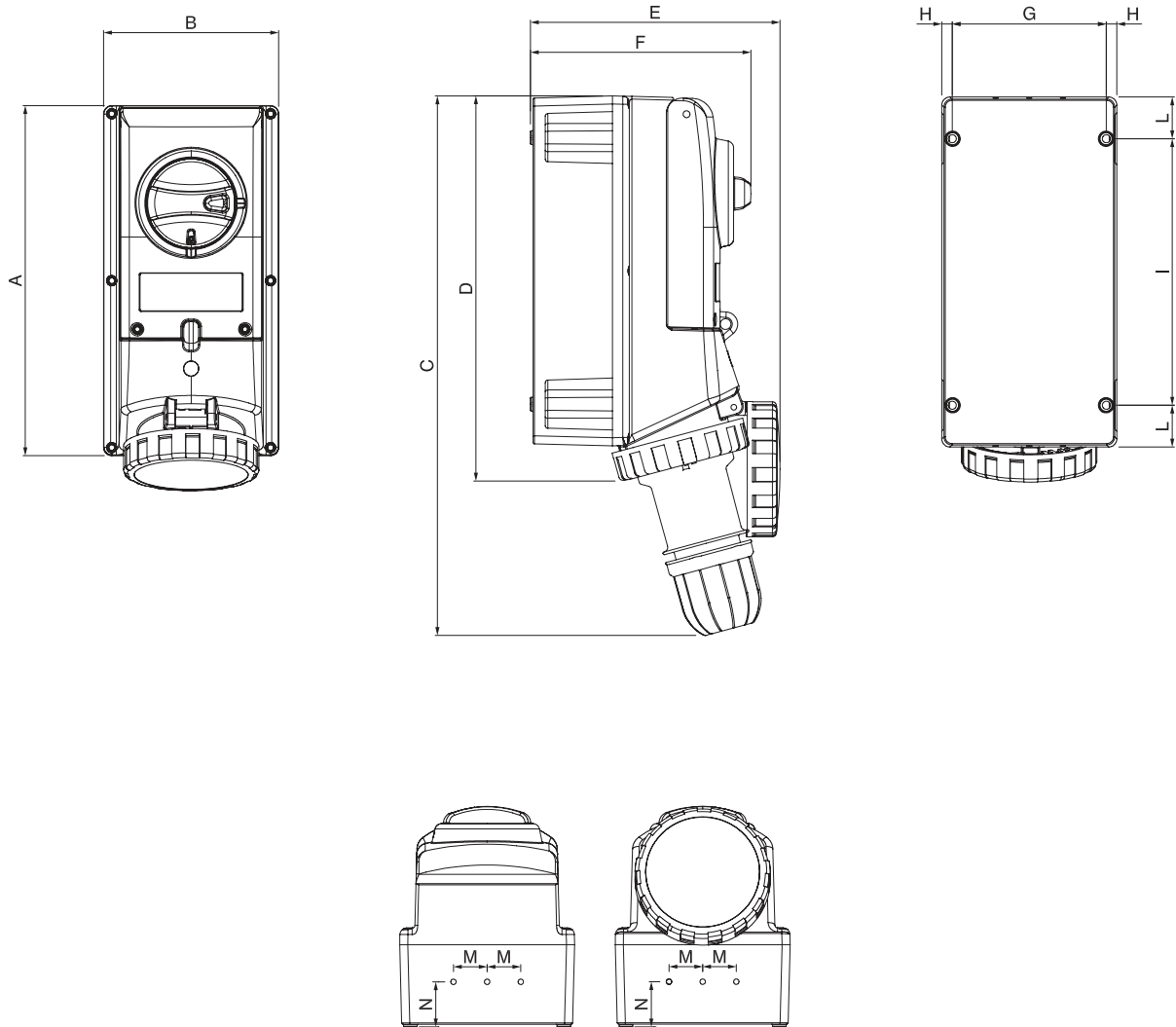

VERSIONS	A	B	C	D	E	F	G	H	I	L	M	N
2P+E 16A	260	130	360	280	170	164	114,5	7,75	198	31	25	33,5
3P+E 16A	260	130	365	282	175	164	114,5	7,75	198	31	25	33,5
3P+N+E 16A	260	130	390	282	182	164	114,5	7,75	198	31	25	33,5
2/3P+E 32A	260	130	390	285	189	164	114,5	7,75	198	31	25	33,5
3P+N+E 32A	260	130	400	286	185	164	114,5	7,75	198	31	25	33,5
2P+E 63A												
3P+E 63A	380	170	550	420	225	203	150	8,3	310	35	32,5	40
3P+N+E 63A												

DIMENSIONS

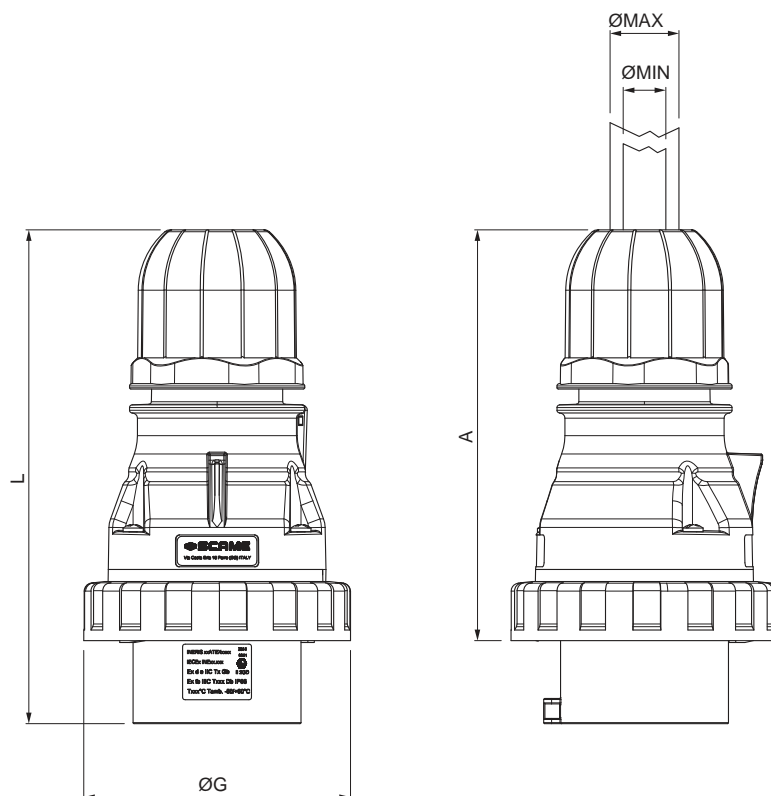

IP66	TYPE	A Min	øG	L Min
16A	2P+E	116	73	140,5
	3P+E	123	81	147,5
32A	3P+N+E	140,5	88	165
	2P+E	142,6	92	174
63A	3P+E	142,6	92	174
	3P+N+E	150	101	180,5
		166,5	112	217,5

ISOLATORS-EX Series



DIMENSIONS

ALUMINIUM ENCLOSURE 20A-32A-40A

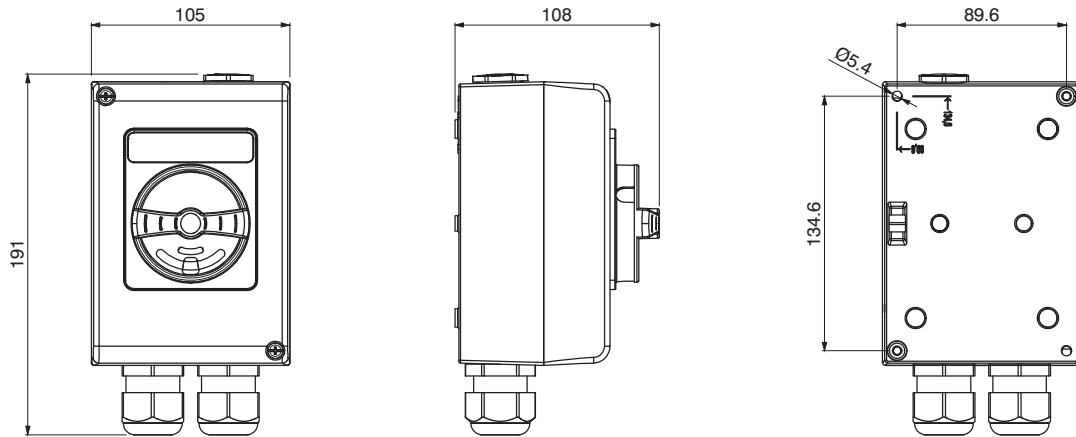

ALUMINIUM ENCLOSURE 63A

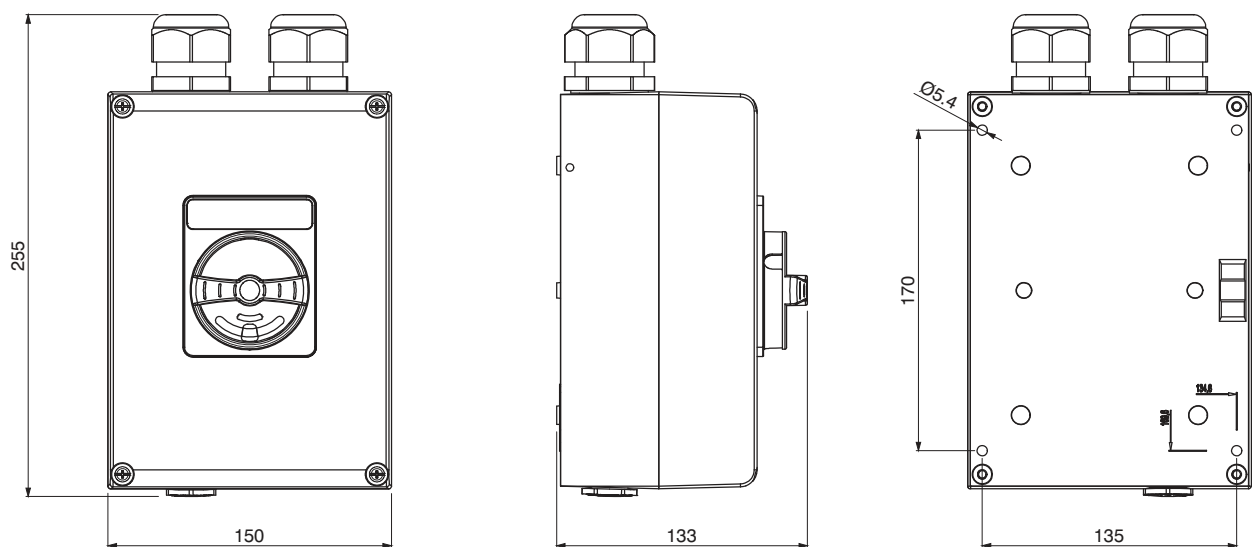

(Dimensions in mm)

THERMOPLASTIC ENCLOSURE 20A-32A-40A

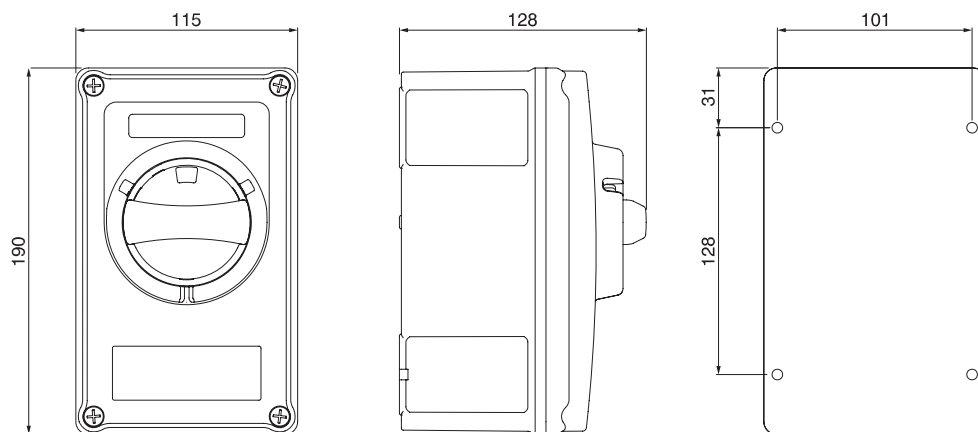

3

ATEX [⊕ II 3D]
ATEX [⊕ II 3GD]

- Zone 2 (Gc)
- Zone 22 (Dc)

GAS&DUST

■ ADVANCE-GRP[EX] System



page 132

■ ADVANCE-GRP[EX] 125A Series



page 136

■ OPTIMA-EX 125A Series



page 138

■ ADVANCE-GRP[EX] 24V Series



page 140

■ OPTIMA-EX 24V Series



page 142

■ ALUBOX-EX Series



page 144

ADVANCE-GRP[EX] System



DISTRIBUTION ASSEMBLIES SWITCHED INTERLOCKED SOCKET OUTLETS



The switched interlocked socket outlets in the ADVANCE-GRP[EX] Series are suitable for the composition of distribution assemblies for installation in environments with classification Ex zone 22/Dc (due to the presence of the combustible dust in group IIIC) in the self-certification scheme. These can be equipped with auxiliary contacts, to be purchased separately, without losing the certification. The use of a GRP material (Glass-fibre Reinforced Polyester) combined with the substantial thickness of the enclosure walls guarantees excellent mechanical resistance and a long life. This material is highly resistant to contamination and corrosion and is suitable for applications requiring the use of components with a low smoke emission and no halogens (LSOH Low Smoke Zero Halogen). The interlocked sockets in the ADVANCE-GRP[EX] Series can be used with plugs in the OPTIMA-EX Series.

TECHNICAL CHARACTERISTICS

Rated current:	16A-25A-32A-40A-45A-55A-60A-70A
Rated voltage:	100÷690V~
Frequency:	50÷60Hz
Insulating voltage:	500/690V~
Self-extinguishing GW test:	960°C
Fuse:	
16A-32A	gG 10,3x38mm
63A	gG 22x58mm
Protection degree:	IP66
Impact Resistance:	7J
Colour:	Grey RAL 7037

REFERENCE STANDARDS

ATEX	EN 60079-0 Electrical apparatus for potentially explosive atmospheres. <i>Part 0: General requirements.</i>
ATEX	EN 60079-31 Electrical apparatus for potentially explosive atmospheres. <i>Part 31: Protection by enclosures "t".</i>
LVD	EN 60309-1 Plugs, socket outlets and couplers for industrial purposes. <i>Part 1: general requirements.</i>
LVD	EN 60309-2 Plugs, socket outlets and couplers for industrial purposes. <i>Part 2: dimensional interchangeability requirements for pin and contact-tube accessories of harmonised configurations.</i>
LVD	EN 60309-4 Plugs, socket-outlets and couplers for industrial purposes. <i>Part 4: Switched socket-outlets and connectors with or without interlock.</i>

Ex CHARACTERISTICS

ATEX Category:	Ex II 3D
Ex Protection type:	Ex tc IIIC Dc -25°C ≤Ta ≤+60°C
Surface temperature class DUST:	T90°C

■ BEHAVIOUR WITH CHEMICAL AND ATMOSPHERIC AGENTS

Saline solution	Acids		Bases		Solvents				Mineral oil	UV rays
	Concentrated	Diluted	Concentrated	Diluted	Hexane	Benzol	Acetone	Alcohol		
Resistant	Limited Resistance	Resistant	Limited Resistance	Resistant	Resistant	Resistant	Resistant	Resistant	Resistant	Resistant

Resistance values to chemical agents have to be considered indicative.

For further information and specific substances, contact the technical service.

■ ELECTRICAL PARAMETERS - AUXILIARY CONTACT

ELECTRICAL PARAMETERS AUXILIARY CONTACT SERIES 590.PL00400X		
Auxiliary contacts	Maximun Current	Note
1NC or 1NO	Max 2A	With 1 Auxiliary contacts the maximum current is 2A
1NC or 1NO	Max 2A	
2NC or 2NO	Max 1A	With 2 Auxiliary contacts the maximum current is 1A each
2NC or 2NO	Max 1A	

See auxiliary contact table page. 115

ADVANCE-GRP[EX] System



■ TECHNICAL FEATURES, CROSS SECTIONAL AREA AND TORQUE

Rated current		16A	32A	63A
Switch-command and/or fuse protection	Catalogue number	Terminals – Torque (Nm)		
Switch type serie Command (SCAME)	402.EX16.... 402.EX32.... 402.EX63....	0,8	0,8	3,6
Switch-Command & fuse 16-32A : 10:3 38 gG 63A : CH 22 X 58 63A gG	402.EX16...F 402.EX32...F 402.EX63...F	0,8	0,8	3,6
Earth terminals	402.EX16.... 402.EX32.... 402.EX63....	1,2	1,2	3,5

CABLE ENTRY

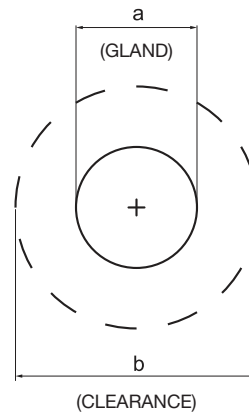
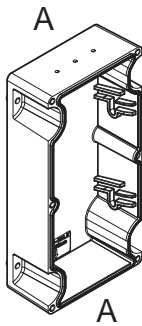

16A/32A WxD (mm ²)	63A WxD (mm ²)	Type cable entry M	GLAND a (mm)	CLEARANCE b (mm)	Area A n°	
80x45	110x55	16A	M25	33	50	2
		32A	M32	37,5	50	2

NOTE:

For Ex cable glands installations refer to the instructions by manufacturer.

Cable entry for 63A socket have to be done with the only one cable entry type M50x1,5 (kit type, art. 579.EX0201).

■ CROSS SECTIONAL AREAS AND CABLE TEMPERATURE

FINELY-STRANDED 16A: 4mm² - 32A: 10mm² - 63A: 25mm²

SINGLE-WIRE 16A: 4mm² - 32A: 10mm² - 63A: 25mm²

Rated current	Max. current			Optima-EX ΔT cable
	T. amb 40°C	T. amb 50°C	T. amb 60°C	
16A	-	-	16A	-
32A	-	-	25A	-
63A	55A	50A	45A	85°C

DISTRIBUTION ASSEMBLIES SWITCHED INTERLOCKED SOCKET OUTLETS - IP66

N° Socket outlets	16A			32A			63A		Rated current	Rated voltage	Terminal (mmq)	Cable entries (*)	
	2P+E	3P+E	3P+N+E	2P+E	3P+E	3P+N+E	3P+E	2P+E					
1	1								16A	230V	3x6	M32	579.EX10-126
			1						16A	400V	5x6	M32	579.EX10-127
						1			32A	400V	5x10	M32	579.EX10-129
2			2						25A	400V	5x10	M32	579.EX20-103
	1		1						25A	400V	5x6	M32	579.EX20-104
	1					1			32A	400V	5x16	M32	579.EX20-105
	1	1							25A	400V	5x6	M32	579.EX20-113
	2								25A	230V	3x6	M32	579.EX20-125
			2						25A	400V	4x6	M32	579.EX20-128
	1				1				32A	400V	5x16	M32	579.EX20-151
		1	1						25A	400V	5x10	M32	579.EX20-155
					2				40A	400V	4x35	M40	579.EX20-161
		1		2					25A	400V	5x16	M32	579.EX30-109
3	2		1						25A	400V	5x10	M32	579.EX30-115
	1		1			1			32A	400V	5x16	M32	579.EX30-116
	1	1			1				32A	400V	5x16	M32	579.EX30-122
	3								25A	230V	3x10	M32	579.EX30-130
	2	1							25A	400V	5x10	M32	579.EX30-132
	1	2							25A	400V	5x10	M32	579.EX30-152
	1	1				1			32A	400V	5x16	M32	579.EX30-153
	1				1	1			55A	400V	5x35	M32	579.EX30-156
	1				2				55A	400V	5x35	M32	579.EX30-163
	1				1		1		70A	400V	5x35	M50	579.EX30-173
2				1				32A	400V	5x16	M32	579.EX30-175	
1		1					1	60A	400V	5x16	M32	579.EX30-176	
4	1		3						40A	400V	5x16	M32	579.EX40-106
	3		1						40A	400V	5x16	M32	579.EX40-107
	2		2						40A	400V	5x16	M32	579.EX40-108
	1	3							40A	400V	5x16	M32	579.EX40-123
	2		1			1			45A	400V	5x16	M32	579.EX40-131
	2				2				45A	400V	5x16	M32	579.EX40-132
	1		1			1		1	70A	400V	5x35	M50	579.EX40-133
		3	1						40A	400V	5x16	M32	579.EX40-154
	2					2			45A	400V	5x16	M32	579.EX40-162

(*) To drill

ADVANCE-GRP[EX] 125A Series



SWITCHED INTERLOCKED SOCKET OUTLETS



The switched interlocked socket outlets in the ADVANCE-GRP Series are suitable for installation in environments with classification Ex zone 22/Dc (due to the presence of the combustible dust in group IIIC) in the self-certification scheme.

It is possible to install auxiliary contacts, to be purchased separately, without losing the certification

The use of a GRP material (Glass-fibre Reinforced Polyester) combined with the substantial thickness of the enclosure walls guarantees excellent mechanical resistance and a long life. This material is highly resistant to contamination and corrosion and is suitable for applications requiring the use of components with a low smoke emission and no halogens (LSOH Low Smoke Zero Halogen).

They can be used with plugs in the OPTIMA-EX Series.

VERSIONS

	With switch-disconnector
	With switch-disconnector and fuse
	With fuse and switch-disconnector

REFERENCE STANDARDS

ATEX	EN 60079-0 Electrical apparatus for potentially explosive atmospheres. <i>Part 0: General requirements.</i>
ATEX	EN 60079-31 Electrical apparatus for potentially explosive atmospheres. <i>Part 31: Protection by enclosures "t".</i>
LVD	EN 60309-1 Plugs, socket outlets and couplers for industrial purposes. <i>Part 1: general requirements.</i>
LVD	EN 60309-2 Plugs, socket outlets and couplers for industrial purposes. <i>Part 2: dimensional interchangeability requirements for pin and contact-tube accessories of harmonised configurations.</i>
LVD	EN 60309-4 Plugs, socket-outlets and couplers for industrial purposes. <i>Part 4: Switched socket-outlets and connectors with or without interlock.</i>

	With molded case circuit breaker with thermal magnetic trip unit
	With molded case circuit breaker with thermal magnetic and residual current release trip units
	With contactor

BEHAVIOUR WITH CHEMICAL AND ATMOSPHERIC AGENTS

Saline solution	Acids		Bases		Solvents				Mineral oil	UV rays
	Concentrated	Diluted	Concentrated	Diluted	Hexane	Benzol	Acetone	Alcohol		
Resistant	Limited Resistance	Resistant	Limited Resistance	Resistant	Resistant	Resistant	Resistant	Resistant	Resistant	Resistant

Resistance values to chemical agents have to be considered indicative.

For further information and specific substances, contact the technical service.

TECHNICAL CHARACTERISTICS

Rated current:	125A
Rated voltage:	100÷690V~
Frequency:	50÷60Hz
Insulating voltage:	500/690V~
Self-extinguishing GW test:	960°C
Self-extinguishing UL94:	V0
Fuse:	NH00
Protection degree:	IP66
Impact Resistance:	7J
Colour:	grey RAL 7037

Ex CHARACTERISTICS

ATEX Category:	Ex II 3D
Ex Protection type:	Ex tc IIIC Dc -25°C ≤Ta ≤+60°C
Surface temperature class DUST:	T90°C

CABLE ENTRY

Maximum entry with cable glands

Rated current (A)	Single socket	
	Upper	Lower
125A	M63	M63

WIRING OPERATIONS

Wiring capacity of the terminals (mm²)

Rated current (A)	Socket outlets	
	Min	Max
125A	50	95 (*)

(*) In case of flexible cable max 70 mm².

SWITCHED INTERLOCKED SOCKET OUTLET 125A - IP66



Poles	Hz	Volt	Colour	h	
3P+E	50/60	346-415		6	503.12587

Add at the end of the code:

- F: with switch-disconnector and fuse

- FS: with fuse and switch-disconnector

- M: with molded case circuit breaker with thermal magnetic trip unit

- RM: with molded case circuit breaker with thermal magnetic and residual current release trip units

- T: with contactor

OPTIMA-EX 125A Series



PLUGS



Plugs in the OPTIMA-EX Series are suitable for use in environments with classification Ex zone 22/Dc (due to the presence of the combustible dust in group IIIC) in the self-certification scheme. They are compatible with the interlocked sockets in the ADVANCE-GRP Series, but can be connected, when in a "safe zone", to any socket compliant with the industrial standard IEC/EN 60309 having the same polarity.

VERSIONS

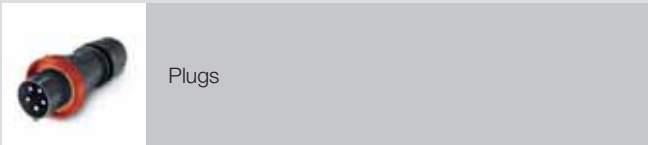

Plugs

TECHNICAL CHARACTERISTICS

Rated current:	125A
Rated voltage:	100÷690V~
Frequency:	50÷60Hz
Insulating voltage:	500/690V~
Self-extinguishing GW test:	960°C
Protection degree:	IP66
Impact Resistance:	7J
Plugs material:	Thermoplastic
Plugs colour:	Black RAL 9011

REFERENCE STANDARDS

ATEX	EN 60079-0 Electrical apparatus for potentially explosive atmospheres. <i>Part 0: General requirements.</i>
ATEX	EN 60079-31 Electrical apparatus for potentially explosive atmospheres. <i>Part 31: Protection by enclosures "t".</i>
LVD	EN 60309-1 Plugs, socket outlets and couplers for industrial purposes. <i>Part 1: general requirements.</i>
LVD	EN 60309-2 Plugs, socket outlets and couplers for industrial purposes. <i>Part 2: dimensional interchangeability requirements for pin and contact-tube accessories of harmonised configurations.</i>

Ex CHARACTERISTICS

ATEX Category:	Ex II 3D
Ex Protection type:	Ex tc IIIC Dc -25°C ≤ Ta ≤ +60°C
Surface temperature class DUST:	T90°C

BEHAVIOUR WITH CHEMICAL AND ATMOSPHERIC AGENTS

Saline solution	Acids		Bases		Solvents				Mineral oil	UV rays
	Concentrated	Diluted	Concentrated	Diluted	Hexane	Benzol	Acetone	Alcohol		
Resistant	Limited Resistance	Resistant	Limited Resistance	Resistant	Resistant	Resistant	Resistant	Resistant	Resistant	Resistant

Resistance values to chemical agents have to be considered indicative.

For further information and specific substances, contact the technical service.

TECHNICAL FEATURES

Rated Current	Unit		Value 125A
Code			218.EX125...
Cable section L1 – L2 – L3 – N Ground cable section	(mm ²)		50
Power Supply Terminals Tightening-Torque	(Nm)		4
Cable size accepted by Cable-Clamp (eg.H07RN-F) Do not use armoured cable	(mm)	2P+E	30
		3P+E	
		3P+N+E	
Cable Gland/Cable-Clamp Tightening-Torque	(Nm)	2P+E	25
		3P+E	
		3P+N+E	
Cable-Gland/Cable-Clamp (Screw) - Tightening-Torque	(Nm)		0.8
Handle Screws – Tightening-Torque	(Nm)		1,5

PLUGS 125A - IP66



Poles	Hz	Volt	Colour	h	
2P+E	50/60	200-250		6	218.EX12533
3P+E	50/60	380-415		6	218.EX12536
3P+E	50/60	440-460		11	218.EX125365
3P+N+E	50/60	346-415		6	218.EX12537

ADVANCE-GRP[EX] 24V Series



SWITCHED INTERLOCKED SOCKET OUTLETS



The sockets with electrical interlock in the ADVANCE-GRP Series for very low voltage are suitable for installation in environments with classification Ex zone 22/Dc (due to the presence of the combustible dust in group IIIC) in the self-certification scheme.

The use of a GRP material (Glass-fibre Reinforced Polyester) combined with the substantial thickness of the enclosure walls guarantees excellent mechanical resistance and a long life.

This material is highly resistant to contamination and corrosion and is suitable for applications requiring the use of components with a low smoke emission and no halogens (LSOH Low Smoke Zero Halogen). They can be used with plugs in the OPTIMA-EX 24V Series.

VERSIONS



Switched interlocked socket outlets with consumer unit

TECHNICAL CHARACTERISTICS

Rated current:	16A
Rated voltage:	24V~
Frequency:	50÷60Hz
Self-extinguishing GW test:	960°C
Fuse:	16A gG 10,3x38mm
Protection degree:	IP66
Impact Resistance:	4J
Colour:	Grey RAL 7037

REFERENCE STANDARDS

ATEX	EN 60079-0 Electrical apparatus for potentially explosive atmospheres. <i>Part 0: General requirements.</i>
ATEX	EN 60079-31 Electrical apparatus for potentially explosive atmospheres. <i>Part 31: Protection by enclosures "t".</i>
LVD	EN 60309-1 Plugs, socket outlets and couplers for industrial purposes. <i>Part 1: general requirements.</i>
LVD	EN 60309-2 Plugs, socket outlets and couplers for industrial purposes. <i>Part 2: dimensional interchangeability requirements for pin and contact-tube accessories of harmonised configurations.</i>
LVD	EN 60309-4 Plugs, socket-outlets and couplers for industrial purposes. <i>Part 4: Switched socket-outlets and connectors with or without interlock.</i>

Ex CHARACTERISTICS

ATEX Category:	Ex II 3D
Ex Protection type:	Ex tc IIIC Dc -25°C ≤ Ta ≤ +60°C
Surface temperature class DUST:	T90°C

BEHAVIOUR WITH CHEMICAL AND ATMOSPHERIC AGENTS

Saline solution	Acids		Bases		Solvents				Mineral oil	UV rays
	Concentrated	Diluted	Concentrated	Diluted	Hexane	Benzol	Acetone	Alcohol		
Resistant	Limited Resistance	Resistant	Limited Resistance	Resistant	Resistant	Resistant	Resistant	Resistant	Resistant	Resistant

Resistance values to chemical agents have to be considered indicative.

For further information and specific substances, contact the technical service.

CABLE ENTRY

Maximum entry with cable glands

Rated current (A)	Single socket	
	Upper	Lower
16A	M32	M32

WIRING OPERATIONS

Wiring capacity of the terminals (mm²)

Rated current (A)	Socket outlets
	Min
16A	2,5 mm ²

EXTRA LOW VOLTAGE SOCKET OUTLETS < 50V - IP66

Poles	Colour	Rated voltage		
2P		20-25V		 503.2416-F

OPTIMA-EX 24V Series



PLUGS



Plugs in the OPTIMA-EX Series for very low voltage are suitable for use in environments with classification Ex zone 22/Dc (due to the presence of the combustible dust in group IIIC) in the self-certification scheme. They are compatible with the interlocked sockets in the ADVANCE-GRP 24V Series.

VERSIONS

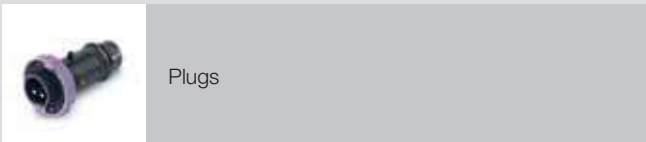

TECHNICAL CHARACTERISTICS

Rated current:	16A
Rated voltage:	24V~
Frequency:	50±60Hz
Self-extinguishing GW test:	960°C
Protection degree:	IP66
Impact Resistance:	4J
Plugs material:	Thermoplastic
Colour:	Black RAL 9011

REFERENCE STANDARDS

ATEX	<p>EN 60079-0 Electrical apparatus for potentially explosive atmospheres. <i>Part 0: General requirements.</i></p>
ATEX	<p>EN 60079-31 Electrical apparatus for potentially explosive atmospheres. <i>Part 31: Protection by enclosures "t".</i></p>
LVD	<p>EN 60309-1 Plugs, socket outlets and couplers for industrial purposes. <i>Part 1: general requirements.</i></p>
LVD	<p>EN 60309-2 Plugs, socket outlets and couplers for industrial purposes. <i>Part 2: dimensional interchangeability requirements for pin and contact-tube accessories of harmonised configurations.</i></p>

Ex CHARACTERISTICS

ATEX Category:	Ex II 3D
Ex Protection type:	Ex tc IIIC Db -25°C ≤Ta ≤+60°C
Surface temperature class DUST:	T90°C

BEHAVIOUR WITH CHEMICAL AND ATMOSPHERIC AGENTS

Saline solution	Acids		Bases		Solvents				Mineral oil	UV rays
	Concentrated	Diluted	Concentrated	Diluted	Hexane	Benzol	Acetone	Alcohol		
Resistant	Limited Resistance	Resistant	Limited Resistance	Resistant	Resistant	Resistant	Resistant	Resistant	Resistant	Resistant

Resistance values to chemical agents have to be considered indicative.

For further information and specific substances, contact the technical service.

TECHNICAL FEATURES

Plugs OPTIMA-EX Series	Unit		Value
Rated current In			16A
Rated voltage	V		20-25
Code			235.EX1600
Size cables naked flexible copper suitable for power and ground terminals	(mm ²)		4-10
Power supply terminals - Tightening torque	(Nm)		1,2
Cable clamp screw - Tightening torque	(Nm)		0,8
Cable size accepted by Cable-Clamp	(mm)	2P	8-15
Cable gland / Cable clamp - Tightening torque	(Nm)	2P	4
Handle screws - Tightening torque	(Nm)		0,8

EXTRA LOW VOLTAGE PLUGS < 50V - IP66



Poles	Hz	Volt	Colour	
2P	20/25	0-50		235.EX1600

ALUBOX-EX Series



EMPTY ENCLOSURES



The ALUBOX-EX Series includes 7 different sized enclosures made in die-cast painted aluminium. For large batches, Scame offers the possibility for customisation with terminals (junction boxes).

VERSIONS

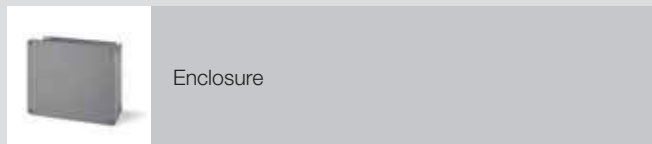

TECHNICAL CHARACTERISTICS

Service temperature:	-20°C ≤Ts ≤+80°C
Protection degree:	IP66
Impact resistance:	4J
Material:	Aluminium alloy
DIN rail fixing:	Yes
Colour:	RAL 7037

REFERENCE STANDARDS

ATEX	EN 60079-0 Electrical apparatus for potentially explosive atmospheres. <i>Part 0: General requirements.</i>
ATEX	EN 60079-15 Electrical apparatus for use in the presence of combustible dust. <i>Part 15: Equipment protection by type of protection "n".</i>
ATEX	EN 60079-31 Electrical apparatus for potentially explosive atmospheres. <i>Part 31: Protection by enclosures "t".</i>
LVD	EN 60670-22 Boxes and enclosures for electrical accessories for household and similar fixed electrical installations. <i>Part 22: particular requirements for connecting boxes and enclosures.</i>

Ex CHARACTERISTICS

ATEX Category:	Ex II 3GD
Ex Protection type:	Ex nA IIC Gc Ex tc IIIC Dc

BEHAVIOUR WITH CHEMICAL AND ATMOSPHERIC AGENTS

Saline solution	Acids		Bases		Solvents				Mineral oil	UV rays
	Concentrated	Diluted	Concentrated	Diluted	Hexane	Benzol	Acetone	Alcohol		
Resistant	Limited Resistance	Resistant	Limited Resistance	Resistant	Limited Resistance	Limited Resistance	Limited Resistance	Resistant	Resistant	Resistant

Resistance values to chemical agents have to be considered indicative. For further information and specific substances, contact the technical service.

ENCLOSURES - IP66



Dimensions (mm)	Screw for attaching cover	Earthing screws	Weight (Kg)		
100 x 100 x 59	☒ n° 2 M5x10mm	n°1 M4x6	0,290	1/32	653.9000
140 x 115 x 60	☒ n° 4 M5x16mm	n°1 M4x6	0,390	1/24	653.9001
166 x 142 x 64	☒ n° 4 M5x16mm	n°1 M4x6	0,614	1/16	653.9002
192 x 168 x 80	☒ n° 4 M5x16mm	n°1 M4x6	0,920	1/12	653.9003
253 x 217 x 93	☒ n° 4 M6x20mm	n°1 M4x6	1,430	1/6	653.9004
314 x 264 x 122	☒ n° 4 M6x20mm	n°1 M4x6	2,236	1/2	653.9005
410 x 315 x 153	☒ n° 4 M6x20mm	n°1 M4x6	3,861	1	653.9007

- Enclosure and cover in die-cast aluminium.
- Externally varnished.
- With stainless steel screws for attaching cover and self-tapping zinc-coated steel screws for earthing the enclosure and cover.

☒ = Counter-sunk head screw.
☒ = Flat head screw.

MOUNTING PLATES

For enclosures (mm)	Screw for attaching cover	Thickness (mm)	Weight (Kg)		
100 x 100 x 59					
140 x 115 x 60	n° 4 M4x6	1,5	0,140	1/40	653.011
166 x 142 x 64	n° 4 M4x6	1,5	0,213	1/20	653.012
192 x 168 x 80	n° 4 M4x6	1,5	0,245	1/20	653.013
253 x 217 x 93	n° 4 M4x6	1,5	0,423	1/10	653.014
314 x 264 x 122	n° 4 M4x6	1,5	0,626	1/10	653.015
410 x 315 x 153	n° 4 M4x6	2	1,436	5	653.017

- Zinc-coated steel plate.
- With zinc-coated steel self-tapping screws for attaching the plate.

DIN RAIL KIT

1		653.020
1		653.021
1		653.022
1		653.023
1		653.024
1		653.025
1		653.027



Enclosures and covers in aluminium alloy with blank walls and covered.



Holding seal in expanded EPDM, already mounted in place on the cover.



Fixing to wall by brackets incorporated in the enclosure base.

- Available as junction boxes.
- Minimum order quantity: 50 pcs.

3

ATEX [⊕x II 3D]
ATEX [⊕x II 3GD]

- Zone 2 (Gc)
- Zone 22 (Dc)

DIMENSIONS

SOCKET OUTLETS 125A

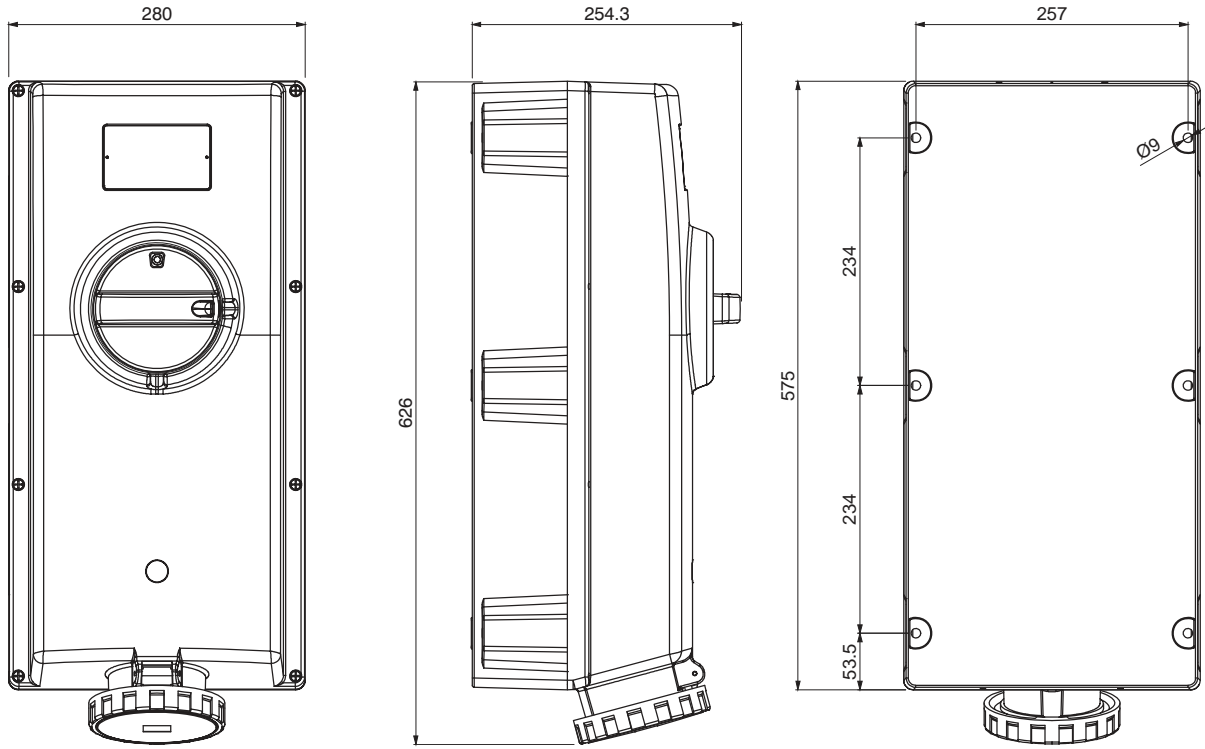

SOCKET OUTLET 24V

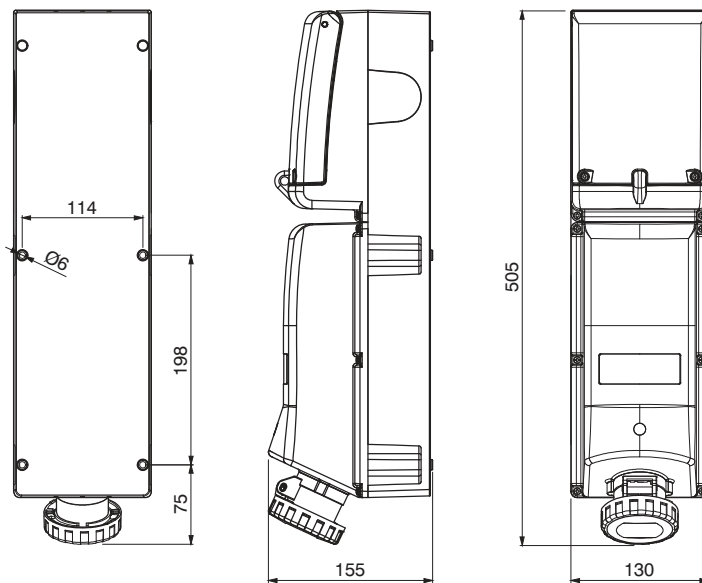

DIMENSIONS

PLUGS 125A

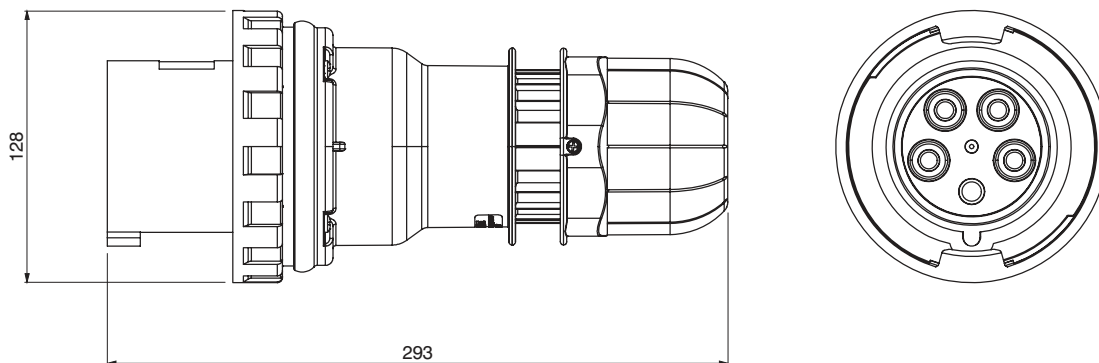

PLUGS 24V

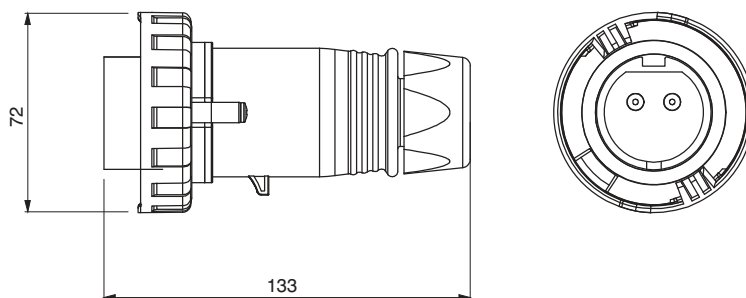

DIMENSIONS

ENCLOSURES

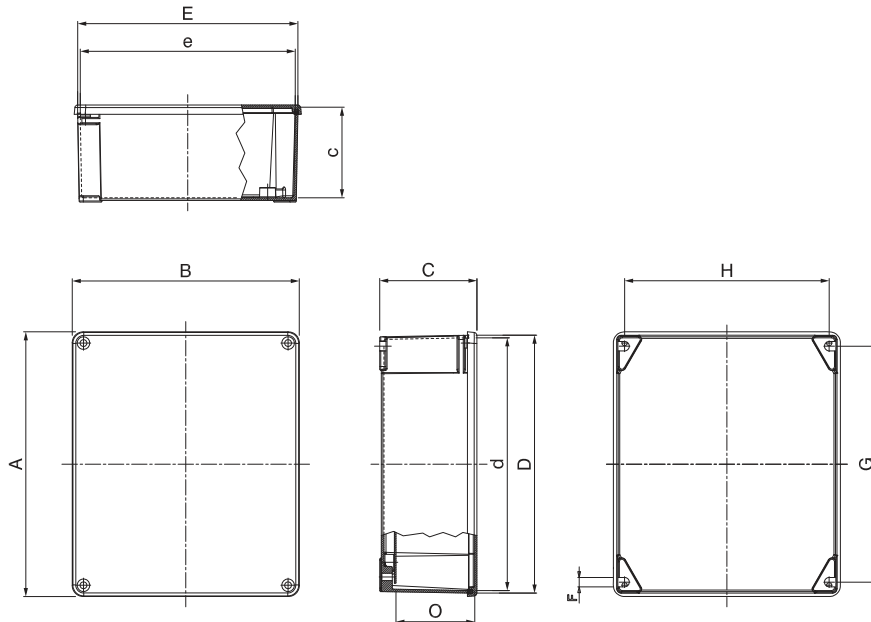

□	External dimensions (with cover)			External box dimensions		Internal dimensions (with cover)			Surface mounting points			Useful height	
	A mm	B mm	C mm	D mm	E mm	c mm	d mm	e mm	F mm	G mm	H mm	O mm	
653.9000	32	100	100	59	94	94	53	90	90	6	88	80	X
653.9001	24	140	115	60	134	109	55	130	104	6	120	100	45
653.9002	16	166	142	64	160	136	58	156	132	7,5	144	125	48
653.9003	12	192	168	80	185	161	74	180	156	6	168	149	64
653.9004	6	253	217	93	247	211	85	242	206	9	226	196	75
653.9005	2	314	264	122	305	255	114	299	249	9	275	236	103
653.9007	1	410	315	153	400	305	144	393	298	9	367	283	127

MOUNTING PLATES

□	Box reference (mm)	I mm	L mm	M mm	N mm
653.011	1 140x115	122	97	107	66
653.012	1 166x142	147	123	121	98
653.013	1 192x168	165	124	153	112
653.014	1 253x217	206	172	188	153
653.015	1 314x264	254	210	238	198
653.017	1 410x315	349	260	333	248

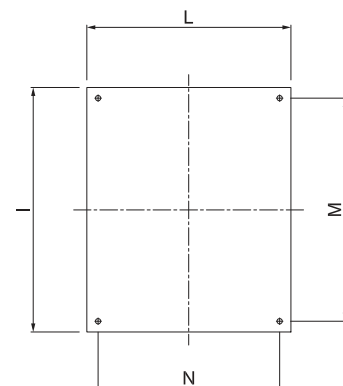

INDEX BY
PRODUCT
NUMBER



www.scame.com

Index by product number

CODE	PAGE
218. OPTIMA-EX Series	
218.EX12533	139
218.EX12536	139
218.EX125365	139
218.EX12537	139
218.EX1630	119
218.EX1633	119
218.EX1636	119
218.EX1637	119
218.EX3233	119
218.EX3236	119
218.EX3237	119
218.EX6333	119
218.EX6336	119
218.EX6337	119
219. OPTIMA-EX[GD] Series	
219.12531	35
219.12532	35
219.12534	35
219.12535	35
219.12536	35
219.125361	35
219.125362	35
219.125364	35
219.125365	35
219.125366	35
219.125367	35
219.12537	35
219.125372	35
219.125374	35
219.125375	35
219.125376	35
219.125377	35
219.1630	35
219.1631	35
219.1632	35
219.1633	35
219.16332	35
219.16336	35
219.1634	35
219.1635	35
219.1636	35
219.16361	35
219.16362	35
219.16364	35
219.16365	35
219.16366	35
219.16367	35
219.1637	35
219.16372	35

CODE	PAGE
219.16374	35
219.16375	35
219.16376	35
219.16377	35
219.1638	35
219.3230	35
219.3231	35
219.3232	35
219.3233	35
219.32332	35
219.32336	35
219.3234	35
219.3235	35
219.3236	35
219.32361	35
219.32362	35
219.32364	35
219.32365	35
219.32366	35
219.32367	35
219.3237	35
219.32372	35
219.32374	35
219.32375	35
219.32376	35
219.32377	35
219.3238	35
219.63 37	35
219.6331	35
219.6332	35
219.6334	35
219.6335	35
219.6336	35
219.63361	35
219.63362	35
219.63364	35
219.63365	35
219.63366	35
219.63367	35
219.63372	35
219.63374	35
219.63375	35
219.63376	35
219.63377	35
235. OPTIMA-EX 24V Series	
235.EX1600	143
503. ADVANCE-GRP[EX] Series	
503.12587	137
503.1670	115
503.1683	115

CODE	PAGE
503.1683-F	115
503.1686	115
503.1686-F	115
503.1687	115
503.1687-F	115
503.2416-F	141
503.3283	115
503.3283-F	115
503.3286	115
503.3286-F	115
503.3287	115
503.3287-F	115
503.6383	115
503.6383-F	115
503.6386	115
503.6386-F	115
503.6387	115
503.6387-F	115
504. ADVANCE-GRP[GD] Series	
504.12572	30
504.12574	30
504.12575	30
504.12579	30
504.12586	30
504.125861	30
504.125862	30
504.125864	30
504.125865	30
504.125866	30
504.125867	30
504.12587	30
504.125872	30
504.125874	30
504.125875	30
504.125876	30
504.125877	30
504.1670	30
504.1672	30
504.1674	30
504.1675	30
504.1678	30
504.1679	30
504.1683	30
504.16832	30
504.16836	30
504.1686	30
504.16861	30
504.16862	30
504.16864	30
504.16865	30

CODE	PAGE
504.16866	30
504.16867	30
504.1687	30
504.16872	30
504.16874	30
504.16875	30
504.16876	30
504.16877	30
504.3270	30
504.3272	30
504.3274	30
504.3275	30
504.3278	30
504.3279	30
504.3283	30
504.32832	30
504.32836	30
504.3286	30
504.32861	30
504.32862	30
504.32864	30
504.32865	30
504.32866	30
504.32867	30
504.3287	30
504.32872	30
504.32874	30
504.32875	30
504.32876	30
504.32877	30
504.6372	30
504.6374	30
504.6375	30
504.6379	30
504.6386	30
504.63861	30
504.63862	30
504.63864	30
504.63865	30
504.63866	30
504.63867	30
504.6387	30
504.63872	30
504.63874	30
504.63875	30
504.63876	30
504.63877	30
570. Accessories and complementary products	
OPTIMA-EX[GD] Series	
570.90163	35

CODE	PAGE
570.90164	35
570.90165	35
570.90324	35
570.90325	35
570.9063	35
570.9125	35
579. Accessories and complementary products	
ADVANCE-GRP[EX] Series	
579.EX0201	115
579. ADVANCE-GRP[EX] System	
579.EX10-126	135
579.EX10-127	135
579.EX10-129	135
579.EX20-103	135
579.EX20-104	135
579.EX20-105	135
579.EX20-113	135
579.EX20-125	135
579.EX20-128	135
579.EX20-151	135
579.EX20-155	135
579.EX20-161	135
579.EX30-109	135
579.EX30-115	135
579.EX30-116	135
579.EX30-122	135
579.EX30-130	135
579.EX30-132	135
579.EX30-152	135
579.EX30-153	135
579.EX30-156	135
579.EX30-163	135
579.EX30-173	135
579.EX30-175	135
579.EX30-176	135
579.EX40-106	135
579.EX40-107	135
579.EX40-108	135
579.EX40-123	135
579.EX40-131	135
579.EX40-132	135
579.EX40-133	135
579.EX40-154	135
579.EX40-162	135
590. Auxiliary contacts	
COMMAND Series	
590.PL004001	115
590.PL004002	115
590.PL004003	115
590.PL004004	115

CODE	PAGE
590. ISOLATORS-EX Series	
590.XEM2002	124
590.XEM2003	124
590.XEM2004	124
590.XEM3202	124
590.XEM3203	124
590.XEM3204	124
590.XEM4002	124
590.XEM4003	124
590.XEM4004	124
590.XGE2002	124
590.XGE2003	124
590.XGE2004	124
590.XGE3202	124
590.XGE3203	124
590.XGE3204	124
590.XGE4002	124
590.XGE4003	124
590.XGE4004	124
590.XHEM2002	124
590.XHEM2003	124
590.XHEM2004	124
590.XHEM3202	124
590.XHEM3203	124
590.XHEM3204	124
590.XHEM4002	124
590.XHEM4003	124
590.XHEM4004	124
590.XHEM6302	124
590.XHEM6303	124
590.XHEM6304	124
590.XHGE2002	124
590.XHGE2003	124
590.XHGE2004	124
590.XHGE3202	124
590.XHGE3203	124
590.XHGE3204	124
590.XHGE4002	124
590.XHGE4003	124
590.XHGE4004	124
590.XHGE6302	124
590.XHGE6303	124
590.XHGE6304	124
591. ISOLATORS-EX[GD] Series	
591.AEM2002	41
591.AEM2004	41
591.AEM2502	41
591.AEM2504	41
591.AEM3202	41
591.AEM3204	41

Index by product number

CODE	PAGE
591.AEM4002	41
591.AEM4004	41
591.AEM6302	41
591.AEM6304	41
591.AGE2002	41
591.AGE2004	41
591.AGE2502	41
591.AGE2504	41
591.AGE3202	41
591.AGE3204	41
591.AGE4002	41
591.AGE4004	41
591.AGE6302	41
591.AGE6304	41
591.PEM2002	40
591.PEM2004	40
591.PEM2502	40
591.PEM2504	40
591.PEM3202	40
591.PEM3204	40
591.PEM4002	40
591.PEM4004	40
591.PEM6302	40
591.PEM6304	40
591.PGE2002	40
591.PGE2004	40
591.PGE2502	40
591.PGE2504	40
591.PGE3202	40
591.PGE3204	40
591.PGE4002	40
591.PGE4004	40
591.PGE6302	40
591.PGE6304	40
591.SEM2002	40
591.SEM2004	40
591.SEM2502	40
591.SEM2504	40
591.SEM3202	40
591.SEM3204	40
591.SEM4002	40
591.SEM4004	40
591.SEM6302	40
591.SEM6304	40
591.SGE2002	40
591.SGE2004	40
591.SGE2502	40
591.SGE2504	40
591.SGE3202	40
591.SGE3204	40

CODE	PAGE
591.SGE4002	40
591.SGE4004	40
591.SGE6302	40
591.SGE6304	40
592. ROCKER-EX[GD] Series	
592.R001-01	43
592.R001-01-A	43
592.R001-01-B	43
592.R001-02	43
592.R001-02-A	43
592.R001-02-B	43
592.R001-03	43
592.R001-03-A	43
592.R001-03-B	43
592.R001-03-P	43
592.R002-01	43
592.R002-01-A	43
592.R002-01-B	43
592.R002-02	43
592.R002-02-A	43
592.R002-02-B	43
592.R002-03	43
592.R002-03-A	43
592.R002-03-B	43
592.R002-03-P	43
592.R003-01	43
592.R003-01-A	43
592.R003-01-B	43
592.R003-02	43
592.R003-02-A	43
592.R003-02-B	43
592.R003-02-P	43
644. ZENITH-P Series	
644.0100	52
644.0100L	52
644.0110	52
644.0110L	52
644.0120	52
644.0120L	52
644.0130	52
644.0130L	52
644.0140	52
644.0140L	52
644.0200	52
644.0200L	52
644.0210	52
644.0210-J10	55
644.0210L	52
644.0220	52
644.0220-J14	55

CODE	PAGE
644.0220L	52
644.0230	52
644.0230L	52
644.0240	52
644.0240-J20	55
644.0240L	52
644.0345	52
644.0345-ES	55
644.0345-ESL	56
644.0345-J01	54
644.0345-J02	54
644.0345-J03	54
644.0345-J04	54
644.0345L	52
644.0345-LDB	56
644.0345-LDG	56
644.0345-LDR	56
644.0345-LDW	56
644.0345-LDY	56
644.0345-OF	57
644.0345-PBG	56
644.0345-PBK	56
644.0345-PBR	56
644.0345-PBW	56
644.0345-PBY	56
644.0345-SE1	57
644.0345-SE1L	58
644.0345-SE2	57
644.0345-SE3	57
644.0350	52
644.0350L	52
644.0350-OFE	58
644.0350-SE	59
644.0350-SGS	58
644.0350-SS	58
644.0360	52
644.0360L	52
644.0370	52
644.0370L	52
644.0380	52
644.0380L	52
644.0390	52
644.0390L	52
644.0465	52
644.0465L	52
644.0485	52
644.0485L	52
644.0595	52
644.0595L	52
644.A0100	52

CODE	PAGE
644.A0110	52
644.A0120	52
644.A0130	52
644.A0140	52
644.A0200	52
644.A0210	52
644.A0220	52
644.A0230	52
644.A0240	52
644.A0345	52
644.A0350	52
644.A0360	52
644.A0370	52
644.A0380	52
644.A0390	52
644.A0465	52
644.A0485	52
644.A0595	52
644.B00	52
644.B00	52
644.B10	52
644.B10	52
644.B20	52
644.B20	52
644.B30	52
644.B30	52
644.B40	52
644.B40	52
644.B45	52
644.B50	52
644.B60	52
644.B65	52
644.B70	52
644.B80	52
644.B85	52
644.B90	52
644.B95	52
644.C075	53
644.C120	53
644.C160	53
644.D075	53
644.D120	53
644.D160	53
644.D250	53
644.D405	53
644.E650	53
644.E651	53
644.G001	53
644.G002	53
644.G003	53

CODE	PAGE
644.G004	53
644.G005	53
644.G006	53
645. ZENITH-S Series	
645.B4F	68
645.B4P03	68
645.B4P04	68
645.B4P05	68
645.B4P06	68
645.B4P07	68
645.B4P08	68
645.B4P09	68
645.B4P10	68
645.B4P11	68
645.B4P12	68
645.B4P13	68
645.B4P14	68
645.B4S01	68
645.B4S02	68
645.B4S03	68
645.B4S04	68
645.B4S05	68
645.B4S06	68
645.B4S07	68
645.B4S08	68
645.B4S09	68
645.B4S10	68
645.B4S11	68
645.B4S12	68
645.B4S13	68
645.B4S14	68
645.B6F	67
645.B6P03	67
645.B6P04	67
645.B6P05	67
645.B6P06	67
645.B6P07	67
645.B6P08	67
645.B6P09	67
645.B6P10	67
645.B6P11	67
645.B6P12	67
645.B6P13	67
645.B6P14	67
645.B6S01	67
645.B6S02	67
645.B6S03	67
645.B6S04	67
645.B6S05	67
645.B6S06	67

CODE	PAGE
645.B6S07	67
645.B6S08	67
645.B6S09	67
645.B6S10	67
645.B6S11	67
645.B6S12	67
645.B6S13	67
645.B6S14	67
645.B8P03	67-68
645.B8P04	67-68
645.B8P05	67-68
645.B8P06	67-68
645.B8P07	67-68
645.B8P08	67-68
645.B8P09	67-68
645.B8P10	67-68
645.B8P11	67-68
645.B8P12	67-68
645.B8P13	67-68
645.B8P14	67-68
645.C4F	77
645.C4P00	77
645.C4P01	77
645.C4P02	77
645.C4P03	77
645.C4P05	77
645.C4P06	77
645.C4P07	77
645.C4P09	77
645.C4P11	77
645.C4P13	77
645.C4P16	77
645.C4P19	77
645.C4P22	77
645.C4P23	77
645.C4P24	77
645.C4S000	77
645.C4S010	77
645.C4S020	77
645.C4S030	77
645.C4S040	77
645.C4S050	77
645.C4S060	77
645.C4S070	77
645.C4S080	77
645.C4S090	77
645.C4S100	77
645.C4S110	77
645.C4S120	77
645.C4S130	77

Index by product number

CODE	PAGE
645.C4S140	77
645.C4S150	77
645.C4S160	77
645.C4S170	77
645.C4S180	77
645.C4S190	77
645.C4S200	77
645.C4S210	77
645.C4S220	77
645.C4S230	77
645.C4S240	77
645.C6F	76
645.C6P00	76-79
645.C6P01	76-79
645.C6P02	76-79
645.C6P03	76-79
645.C6P05	76-79
645.C6P06	76-79
645.C6P07	76-79
645.C6P09	76-79
645.C6P11	76-79
645.C6P13	76
645.C6P16	76-79
645.C6P19	76-79
645.C6P22	76-79
645.C6P23	76-79
645.C6P24	76-79
645.C6S000	76
645.C6S010	76
645.C6S020	76
645.C6S030	76
645.C6S040	76
645.C6S050	76
645.C6S060	76
645.C6S070	76
645.C6S080	76
645.C6S090	76
645.C6S100	76
645.C6S110	76
645.C6S120	76
645.C6S130	76
645.C6S140	76
645.C6S150	76
645.C6S160	76
645.C6S170	76
645.C6S180	76
645.C6S190	76
645.C6S200	76
645.C6S210	76
645.C6S220	76

CODE	PAGE
645.C6S230	76
645.C6S240	76
645.C8P00	76-77-79
645.C8P01	76-77-79
645.C8P02	76-77-79
645.C8P03	76-77-79
645.C8P05	76-77-79
645.C8P06	76-77-79
645.C8P07	76-77-79
645.C8P09	76-77-79
645.C8P11	76-77-79
645.C8P13	76
645.C8P16	76-77-79
645.C8P19	76-77-79
645.C8P22	76-77-79
645.C8P23	76-77-79
645.C8P24	76-77-79
645.D6S000	78
645.D6S001	78
645.D6S002	79
645.D6S003	79
645.D6S004	79
645.D6S010	78
645.D6S011	78
645.D6S012	79
645.D6S013	79
645.D6S014	79
645.D6S020	78
645.D6S021	78
645.D6S022	79
645.D6S023	79
645.D6S024	79
645.D6S030	78
645.D6S031	78
645.D6S032	79
645.D6S033	79
645.D6S034	79
645.D6S050	78
645.D6S051	78
645.D6S052	79
645.D6S053	79
645.D6S054	79
645.D6S070	78
645.D6S071	78
645.D6S072	79
645.D6S073	79
645.D6S074	79
645.D6S090	78
645.D6S091	78
645.D6S092	79

CODE	PAGE
645.D6S093	79
645.D6S094	79
645.D6S110	78
645.D6S111	78
645.D6S112	79
645.D6S113	79
645.D6S114	79
645.D6S140	78
645.D6S141	78
645.D6S142	79
645.D6S143	79
645.D6S144	79
645.D6S160	78
645.D6S161	78
645.D6S162	79
645.D6S163	79
645.D6S164	79
645.D6S190	78
645.D6S191	78
645.D6S192	79
645.D6S193	79
645.D6S194	79
645.D6S220	78
645.D6S221	78
645.D6S222	79
645.D6S223	79
645.D6S224	79
645.D6S230	78
645.D6S231	78
645.D6S232	79
645.D6S233	79
645.D6S234	79
645.D6S240	78
645.D6S241	78
645.D6S242	79
645.D6S243	79
645.D6S244	79
653. ALUBOX-EX Series	
653.011	145
653.012	145
653.013	145
653.014	145
653.015	145
653.017	145
653.020	145
653.021	145
653.022	145
653.023	145
653.024	145
653.025	145

CODE	PAGE
653.027	145
653.9000	145
653.9001	145
653.9002	145
653.9003	145
653.9004	145
653.9005	145
653.9007	145
805. UNION-EX Series	
805.EX5016	90
805.EX5016.K	90
805.EX5020	90
805.EX5020.K	90
805.EX5025	90
805.EX5025.K	90
805.EX5032	90
805.EX5032.K	90
805.EX5040	90
805.EX5040.K	90
805.EX5050	90
805.EX5050.K	90
805.EX5063	90
805.EX5063.K	90
805.EX5112	90
805.EX5112.K	90
805.EX5116	90
805.EX5116.K	90
805.EX5120	90
805.EX5120.K	90
805.EX5125	90
805.EX5125.K	90
805.EX5132	90
805.EX5132.K	90
805.EX5140	90
805.EX5140.K	90
805.EX5150	90
805.EX5150.K	90
805.EX5412.B	88
805.EX5412.BR	89
805.EX5412.K	88
805.EX5412.KR	89
805.EX5416.B	88
805.EX5416.BR	89
805.EX5416.K	88
805.EX5416.KR	89
805.EX5417.B	88
805.EX5417.BR	89
805.EX5417.K	88
805.EX5417.KR	89
805.EX5420.B	88

CODE	PAGE
805.EX5420.BR	89
805.EX5420.K	88
805.EX5420.KR	89
805.EX5421.B	88
805.EX5421.BR	89
805.EX5421.K	88
805.EX5421.KR	89
805.EX5425.B	88
805.EX5425.BR	89
805.EX5425.K	88
805.EX5425.KR	89
805.EX5426.B	88
805.EX5426.BR	89
805.EX5426.K	88
805.EX5426.KR	89
805.EX5432.B	88
805.EX5432.BR	89
805.EX5432.K	88
805.EX5432.KR	89
805.EX5440.B	88
805.EX5440.BR	89
805.EX5440.K	88
805.EX5440.KR	89
805.EX5450.B	88
805.EX5450.BR	89
805.EX5450.K	88
805.EX5450.KR	89
805.EX5463.B	88
805.EX5463.BR	89
805.EX5463.K	88
805.EX5463.KR	89
805.EX5512.B	88
805.EX5512.BR	89
805.EX5512.K	88
805.EX5512.KR	89
805.EX5516.B	88
805.EX5516.BR	89
805.EX5516.K	88
805.EX5516.KR	89
805.EX5517.B	88
805.EX5517.BR	89
805.EX5517.K	88
805.EX5517.KR	89
805.EX5520.B	88
805.EX5520.BR	89
805.EX5520.K	88
805.EX5520.KR	89
805.EX5521.B	88
805.EX5521.BR	89
805.EX5521.K	88

CODE	PAGE
805.EX5521.KR	89
805.EX5525.B	88
805.EX5525.BR	89
805.EX5525.K	88
805.EX5525.KR	89
805.EX5526.B	88
805.EX5526.BR	89
805.EX5526.K	88
805.EX5526.KR	89
805.EX5532.B	88
805.EX5532.BR	89
805.EX5532.K	88
805.EX5532.KR	89
805.EX5540.B	88
805.EX5540.BR	89
805.EX5540.K	88
805.EX5540.KR	89
805.EX5550.B	88
805.EX5550.BR	89
805.EX5550.K	88
805.EX5550.KR	89
805.EX5563.B	88
805.EX5563.BR	89
805.EX5563.K	88
805.EX5563.KR	89
805.EX5712	91
805.EX5712.K	91
805.EX5716	91
805.EX5716.K	91
805.EX5720	91
805.EX5720.K	91
805.EX5725	91
805.EX5725.K	91
805.EX5732	91
805.EX5732.K	91
805.EX5740	91
805.EX5740.K	91
805.EX5750	91
805.EX5750.K	91
805.EX5763	91
805.EX5763.K	91
805.EX5812	91
805.EX5812.K	91
805.EX5816	91
805.EX5816.K	91
805.EX5820	91
805.EX5820.K	91
805.EX5825	91
805.EX5825.K	91
805.EX5832	91

Index by product number

CODE	PAGE
805.EX5832.K	91
805.EX5840	91
805.EX5840.K	91
805.EX5850	91
805.EX5850.K	91
805.EX5863	91
805.EX5863.K	91
805.EX5912	91
805.EX5912.S	91
805.EX5916	91
805.EX5916.S	91
805.EX5920	91
805.EX5920.S	91
805.EX5925	91
805.EX5925.S	91
805.EX5932	91
805.EX5932.S	91
805.EX5940	91
805.EX5940.S	91
805.EX5950	91
805.EX5950.S	91
805.EX5963	91
805.EX5963.S	91
805.RAD1612.EN	84
805.RAD1612.ES	84
805.RAD1612.SN	85
805.RAD1612.SS	85
805.RAD1616.EN	84
805.RAD1616.ES	84
805.RAD1616.SN	85
805.RAD1616.SS	85
805.RAD1620.EN	84
805.RAD1620.ES	84
805.RAD1620.SN	85
805.RAD1620.SS	85
805.RAD2016.EN	84
805.RAD2016.ES	84
805.RAD2016.SN	85
805.RAD2016.SS	85
805.RAD2020.EN	84
805.RAD2020.ES	84
805.RAD2020.SN	85
805.RAD2020.SS	85
805.RAD2025.EN	84
805.RAD2025.ES	84
805.RAD2025.SN	85
805.RAD2025.SS	85
805.RAD2520.EN	84
805.RAD2520.ES	84
805.RAD2520.SN	85

CODE	PAGE
805.RAD2520.SS	85
805.RAD2525.EN	84
805.RAD2525.ES	84
805.RAD2525.SN	85
805.RAD2525.SS	85
805.RAD3225.EN	84
805.RAD3225.ES	84
805.RAD3225.SN	85
805.RAD3225.SS	85
805.RAD3232.EN	84
805.RAD3232.ES	84
805.RAD3232.SN	85
805.RAD3232.SS	85
805.RAD4040.EN	84
805.RAD4040.ES	84
805.RAD4040.SN	85
805.RAD4040.SS	85
805.RAD5040.EN	84
805.RAD5040.ES	84
805.RAD5040.SN	85
805.RAD5040.SS	85
805.RAD5050.EN	84
805.RAD5050.ES	84
805.RAD5050.SN	85
805.RAD5050.SS	85
805.RAD6350.EN	84
805.RAD6350.ES	84
805.RAD6350.SN	85
805.RAD6350.SS	85
805.RAD6363.EN	84
805.RAD6363.ES	84
805.RAD6363.SN	85
805.RAD6363.SS	85
805.RAD7563.EN	84
805.RAD7563.ES	84
805.RAD7563.SN	85
805.RAD7563.SS	85
805.RAD7575.EN	84
805.RAD7575.ES	84
805.RAD7575.SN	85
805.RAD7575.SS	85
805.RAD9075.EN	84
805.RAD9075.ES	84
805.RAD9075.SN	85
805.RAD9075.SS	85
805.RAD9090.EN	84
805.RAD9090.ES	84
805.RAD9090.SN	85
805.RAD9090.SS	85
805.RAD9175.EN	84

CODE	PAGE
805.RAD9175.ES	84
805.RAD9175.SN	85
805.RAD9175.SS	85
805.RAD9190.EN	84
805.RAD9190.ES	84
805.RAD9190.SN	85
805.RAD9190.SS	85
805.RE12.N	87
805.RE12.S	87
805.RE16.N	87
805.RE16.S	87
805.RE20.N	87
805.RE20.S	87
805.RE25.N	87
805.RE25.S	87
805.RE32.N	87
805.RE32.S	87
805.RE40.N	87
805.RE40.S	87
805.RE50.N	87
805.RE50.S	87
805.RE63.N	87
805.RE63.S	87
805.RE75.N	87
805.RE75.S	87
805.RE90.N	87
805.RE90.S	87
805.RG12.S	87
805.RG12.Y	87
805.RG16.S	87
805.RG16.Y	87
805.RG20.S	87
805.RG20.Y	87
805.RG25.S	87
805.RG25.Y	87
805.RG32.S	87
805.RG32.Y	87
805.RG40.S	87
805.RG40.Y	87
805.RG50.S	87
805.RG50.Y	87
805.RG63.S	87
805.RG63.Y	87
805.RG75.S	87
805.RG75.Y	87
805.RG90.S	87
805.RG90.Y	87
805.RL12.N	86
805.RL12.S	86
805.RL16.N	86

The complete SCAME offer

SYSTEMS CATALOGUE



SCAME offers a wide range of products and solutions for industry, construction site, tertiary and residential application, designed according to the main International Reference Standards.

The offer includes:

- Industrial connectors, mobile or for fix installation, according to IEC and UL Standards
- Interlocked switchsocket outlets according to IEC and UL Standards
- Switch disconnectors
- Enclosures, consumer units and junction boxes
- Cabinets for distribution and automation
- Distribution assemblies
- Domestic connectors, adaptors, multisockets and cable reels
- Accessories and components for electrical installation

E-MOBILITY CATALOGUE



SCAME has been a pathfinder in the E-Mobility field, introducing in the late Nineties the first connector specifically designed for Electric Vehicle recharging. Since that time the basket of products has been developed so to include not only connectors but a wide range of charging stations.

The offer includes:

- Mode 3 wallbox for home charging
- Mode 3 charging stations for public areas
- Mode 4 charging stations for public areas
- Cordset, components and accessories

SCAME PARRE S.p.A.
MEMBER OF:



Scame parre S.p.A. reserves the right to modify products illustrated in this catalogue without prior notice as part of its policy of constant product improvement and development.

ZP00960-GB-2
8 001636 415833



ScameOnLine

www.scame.com
export@scame.com

SCAME PARRE S.p.A.
VIA COSTA ERTA, 15
24020 PARRE (BG) ITALY
TEL. +39 035 705000
FAX +39 035 703122

